

OPERATING MANUAL

MODEL NO. 955 STANDARD
&
MODEL NO. 954 LOW PROFILE

3 HP
230V 1 PHASE
230V 1 PHASE AC DRIVE
460V/575V 3 PHASE

GAS FIRED HOT AIR BLOWER

TRACK SWITCH SNOW MELTER

WITH STEEL TIE DUCT

MANUFACTURED

BY

RECO

RAILWAY EQUIPMENT COMPANY

525 9th STREET SOUTH

DELANO, MINNESOTA 55328

TEL. 763-972-2200

FAX. 763-972-2900

E-Mail:

Technical Support: Techsupport@rwy.com

Sales: Sales@rwy.com



Table of Contents

1.	Warnings and Cautions	1
2.	General Information	5
2.1.	Model Number Description	5
2.2.	Standard Features	5
3.	Component Description	8
3.1.	Main Hot Air Blower (HAB) Unit	8
3.2.	Standard Ductwork	10
3.3.	Optional Ductwork	11
4.	Installation	12
4.1.	Tie Duct	12
4.2.	Main HAB Unit	13
4.3.	Point Nozzles and Track Ducts	15
4.4.	Gas Connection	16
4.5.	Changing the Gas Orifice	20
4.6.	Electrical Connection	22
5.	Control Module	24
5.1.	Description	24
5.2.	Set-Up and Adjustments	26
5.3.	Password 0 and 5 Menus	27
5.3.1.	Status	27
5.3.2.	Factory Defaults	28
5.3.3.	Set Points	28
5.3.4.	Fault History	31
5.4.	Push Buttons and LED Status Indicating Lights	33
5.4.1.	Push Buttons	33
5.4.2.	Led Status Indicating Lights	33
5.5.	Operation	35
5.6.	Fault Conditions	37
6.	Seasonal Maintenance	42
6.1.	Spring	42
6.2.	Fall	42
7.	Motor Greasing Procedure	43
8.	Low Pressure Regulator Adjustment/Output Temp Test	44

9.	Troubleshooting	45
9.1.	Unit Does Not Start	45
9.2.	Unit Does Not Maintain Operation	45
9.3.	Low Heat Level	45
9.4.	Low Airflow	46
9.5.	Gas Valve	46
9.6.	High Heat Level	46
10.	Snow Detector	47
10.1.	Snow Detector Installation	47
10.2.	Snow Detector Operation	48
10.3.	Snow Detector Maintenance	48
10.4.	Snow Detector Troubleshooting	49
10.4.1.	No Heat on the Sensing Head	49
10.4.2.	Does Not Detect Moisture	49
10.4.3.	Constant Indication of Moisture Detection	49
11.	Specifications	50
12.	Drawings	51
13.	Limited Warranty	52

1. Warnings and Cautions



CAUTION

GENERAL HAZARD WARNING

FAILURE TO COMPLY WITH THE PRECAUTIONS AND INSTRUCTIONS PROVIDED WITH THIS HEATER, CAN RESULT IN DEATH, SERIOUS BODILY INJURY AND PROPERTY LOSS OR DAMAGE FROM HAZARDS OF FIRE, EXPLOSION, BURN, ASPHYXIATION, CARBON MONOXIDE POISONING, AND/OR ELECTRICAL SHOCK.

ONLY PERSONS WHO CAN UNDERSTAND AND FOLLOW THESE INSTRUCTIONS SHOULD USE OR SERVICE THIS HEATER.

IF YOU NEED ASSISTANCE OR HEATER INFORMATION, SUCH AS INSTRUCTION MANUALS, LABELS, ETC., CONTACT THE MANUFACTURER.



CAUTION

WARNING: FIRE, BURN, INHALATION, AND EXPLOSION HAZARD.

KEEP SOLID COMBUSTIBLES, SUCH AS BUILDING MATERIALS, PAPER OR CARDBOARD, A SAFE DISTANCE AWAY FROM THE HEATER AS RECOMMENDED BY THE INSTRUCTIONS. NEVER USE THE HEATER IN SPACES WHICH DO OR MAY CONTAIN VOLATILE OR AIRBORNE COMBUSTIBLES, OR PRODUCTS SUCH AS GASOLINE, SOLVENTS, PAINT THINNER, DUST PARTICLES OR UNKNOWN CHEMICALS.



CAUTION

NOT INTENDED FOR INDOOR USE. IT IS ONLY INTENDED FOR OUTDOOR USE.

WARNING: NOT FOR HOME OR RECREATIONAL VEHICLE USE.

The heater is designed and approved for use as a construction heater under ANSI Z83.7

We cannot anticipate every use which may be made of our heaters.
CHECK WITH LOCAL FIRE SAFETY AUTHORITY IF YOU HAVE QUESTIONS ABOUT APPLICATIONS.

Other standards govern the use of fuel gases and heat producing products in specific applications. Your local authority can advise you about these.

PLEASE READ THIS INSTRUCTION MANUAL ENTIRELY BEFORE HANDLING THIS MATERIAL OR ATTEMPTING TO INSTALL, OPERATE OR SERVICE THIS HOT AIR BLOWER SYSTEM.

PLEASE READ THE WARNINGS AND CAUTIONS LISTED BELOW.



SHEET METAL EDGES MAY BE VERY SHARP AND CAN CAUSE SEVERE CUTS OR LACERATIONS. PROTECTIVE GLOVES AND CLOTHING SHOULD BE WORN. USE CAUTION WHEN HANDLING ALL SHEET METAL COMPONENTS.



THE HOT AIR BLOWER TRACK SWITCH SNOW MELTER SYSTEM CAN BE OPERATED REMOTELY OR BY A SNOW DETECTOR SYSTEM. THEREFORE, OPERATION MAY BEGIN UNEXPECTEDLY. USE CAUTION WHEN IN THE AREA.



SYSTEM OPERATES WITH VARIOUS VOLTAGE LEVELS UP TO 600VAC. CONTACT WITH ELECTRICITY CAN BE HAZARDOUS OR LETHAL. MAKE SURE THAT THE MAIN CIRCUIT BREAKER IS TURNED OFF BEFORE ATTEMPTING TO SERVICE THIS SYSTEM. EVEN WITH CIRCUIT BREAKER OFF LINE VOLTAGE IS PRESENT AT THE TOP CIRCUIT BREAKER CONNECTIONS.



THIS SYSTEM CONTAINS A HIGH SPEED AIR FAN WHICH ROTATES AT UP TO 3600RPM AND CREATES FORCEFUL SUCTION WHEN OPERATING. DO NOT OPERATE THE BLOWER SYSTEM IF ANY OF THE DUCTWORK COMPONENTS HAVE BEEN REMOVED.



THIS SYSTEM OPERATES WITH NATURAL GAS OR PROPANE. BOTH ARE GASES WHICH ARE FLAMMABLE AND EXPLOSIVE. USE EXTREME CAUTION WHEN WORKING IN THE AREA. AVOID ANY OPEN FLAME, SPARKS OR OTHER SOURCE OF IGNITION.



THE OUTLET AIR TEMPERATURE FROM THIS GAS SNOW MELTER SYSTEM SHOULD NOT EXCEED 375°F FROM ANY NOZZLE OR DUCT. **DO NOT OPERATE THIS BLOWER SYSTEM IF THE OUTLET TEMPERATURE EXCEEDS 375°F.** AN ACCURATE THERMOMETER SHOULD BE USED TO REGULARLY CHECK THE OUTLET AIR TEMPERATURE. IF THE OUTLET TEMPERATURE EXCEEDS 375°F, CHECK TO MAKE SURE THAT THE FLOW OF AIR IS NOT RESTRICTED AT ANY POINT, THAT THE BLOWER/MOTOR ARE OPERATING PROPERLY, THAT THE CORRECT ORIFICE IS USED FOR THE TYPE OF FUEL USED, AND THAT THE REGULATOR(S) ARE PROPERLY ADJUSTED FOR THE FUEL BEING USED. CONSULT RAILWAY EQUIPMENT COMPANY IF YOU ARE UNABLE TO OPERATE THIS GAS SNOW MELTER SYSTEM BELOW 375°F.

A HIGH TEMPERATURE LIMIT SYSTEM HAS BEEN INCORPORATED INTO ALL RAILWAY EQUIPMENT COMPANY GAS SNOW MELTER SYSTEMS BEGINNING IN 1999. RAILWAY EQUIPMENT COMPANY ALSO HAS A HIGH TEMPERATURE LIMIT MODIFICATION KIT THAT CAN BE ADDED TO GAS SNOW MELTER SYSTEMS MANUFACTURED PRIOR TO 1999. IT IS RECOMMENDED THAT THIS HIGH TEMPERATURE LIMIT SYSTEM BE INSTALLED AND USED. CONSULT RAILWAY EQUIPMENT TO ORDER THE HIGH TEMPERATURE MODIFICATION KIT, OR IF YOU NEED ASSISTANCE REGARDING THE HIGH TEMPERATURE LIMIT SYSTEM.

THIS SNOW MELTER SYSTEM HAS BEEN DESIGNED TO PROVIDE DEPENDABLE EFFECTIVE OPERATION IN ALL WEATHER CONDITIONS WITHOUT SWITCH COVERS. SWITCH COVERS MAY CAUSE HIGHER AIR TEMPERATURES. IF SWITCH COVERS ARE USED, YOU MUST DETERMINE A SAFE OPERATING AIR TEMPERATURE AND ADJUST BURNER PARAMETERS ACCORDINGLY. ADJUSTMENT OF BURNER PARAMETERS MAY NEGATIVELY AFFECT BURNER PERFORMANCE AND COMBUSTION CHARACTERISTICS TO THE EXTENT THAT THE BURNER MAY BE UNABLE TO MAINTAIN COMBUSTION. CONSULT RAILWAY EQUIPMENT COMPANY REGARDING BURNER OPERATING PARAMETERS.

TWO (2) COMPLETE INSTRUCTION MANUALS HAVE BEEN INCLUDED WITH THIS SNOW MELTER SYSTEM. PLEASE KEEP ONE OF THE MANUALS WITH THE SYSTEM AFTER INSTALLATION. ANYONE OPERATING OR SERVICING THIS SNOW MELTER SYSTEM SHOULD READ THE MANUAL ENTIRELY BEFORE PROCEEDING.

IF YOU HAVE ANY QUESTIONS CONCERNING THE MANUFACTURE, DESIGN, FUNCTION, INSTALLATION, OPERATION OR MAINTENANCE, CONTACT RAILWAY EQUIPMENT COMPANY BEFORE PROCEEDING.

2. General Information

2.1. Model Number Description

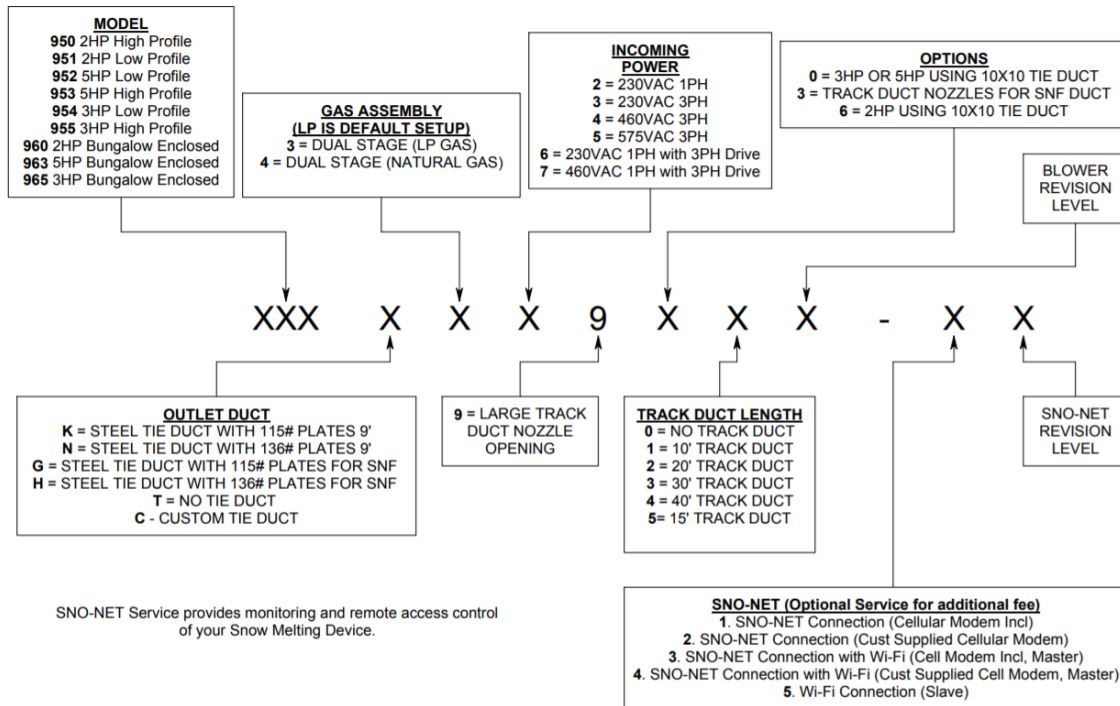

2.2. Standard Features

Here is a list of standard feature that come with the GHAB:

- GHAB complies with AREMA 12.6.10.
- Gas fired operation, allows for both propane and natural gas (convertible in the field).
- Two stage operation that allows savings on fuel costs. Second stage runs at 50% output of the first stage.
- Direct drive motor, totally enclosed fan cooled.
- High efficiency, quiet operation blower.
- Remote operation via contact closure (low voltage, low current) with timed shut off.
- Built-in snow detector system (requires Snow Detector assembly option).
- Auto-Off-Local switch.
- High temperature limit thermostat/shut off.
- Adjustable air temperature control.
- Adjustable rail temperature control.
- Reply indication via GHAB contact closure.
- Fail indication via GHAB contact closure.
- Main circuit breaker.

- Audible tone before blower startup
- Weather tight gasketed control enclosure
- Status indicating lights for all control functions
- Start delay timer for sequential startup
- Run timer for timed operation
- Selectable "Transparent" snow detector operation
- Snow detect timer
- All ductwork and nozzles are thermally and electrically isolated from tracks
- Quick-release track duct
- Blower motor starter with overload protection
- Remote auxiliary gas valve (115VAC) supplied connection
- Gas line accessories:
 - Manual gas valve
 - Gas line strainer
 - Low pressure regulator
 - Flexible gas line connection pipe
- Elevated air intake
- Adjustable delay for start-up (10 sec. -5 min.)
- Complete flame safeguard control:
 - Pre-ignition air purge
 - Air flow proving switch
 - Direct spark ignition
 - Flame proving sensor
 - Post shut off air purge 4 min.
 - Automatic shut off on loss of flame or air flow
 - Leaky gas valve detection
 - Automatic retry on flame loss
 - Automatic reset on flame safeguard control
 - All flame safeguard controls CSA listed
- All components mounted and wired within main unit – no external wiring required except for remote control, indications, optional snow detectors, external gas valve and rail temp sensor.
- Galvanized case constructed of 14-gauge steel, high temperature powder coated finish.
- Convenient panel access to high efficiency burner, flame sensor and spark igniter.
- Galvanized steel adjustable mounting foundations.
- Standard ductwork: flame duct with straight insulated flexible duct and heavy duty insulated offset duct connects to main tie duct

electrically insulated between rails, 24 inch (minimum) switch point nozzles.

The following items are recommended for use with propane gas service:

Tank "pigtail" with POL/POL fittings (P/N 45038-12" or 60127-36")

High pressure regulator (P/N 45103)

Gas line strainer (P/N 45040)

Remote solenoid valve (P/N 45036)

OR

Complete Propane Package (P/N 9458-0100)

3. Component Description

3.1. Main Hot Air Blower (HAB) Unit

a. Main Circuit Breaker

Provides main over-current protection and manual on-off control of electrical power.

b. Motor Contactor

Provides automatic blower motor control, with high current contacts.

c. Motor Overload Relay

Protects the blower motor from an over-current condition.

d. Control Module

Provides complete control of operation. See separate description and details, section 5.

e. Control Transformer

Provides control power for the control module and other control components. The multi-tapped secondary provides 36VAC CT and 17VAC CT. The primary has 115VAC input plus a 230VAC step-up winding and 12.6VAC CT windings.

f. Ignition Transformer

Provides 6000VAC to the spark igniter during the ignition sequence.

g. Airflow Switch

Located in the flame duct, the pressure switch indicates proper airflow before and during burner operation.

h. Burner

Contains the actual flame. Also holds the spark igniter and the flame-sensing rod.

i. Propane/Natural Gas Orifice Plate

Controls the rate of flow of gas to the burner.

j. Spark Igniter

The spark plug type igniter provides spark for the burner. The spark igniter is momentary - sparks only until the flame has been established.

k. Flame Detection Rod

The flame detection rod monitors the flame at the burner nozzle using the rectification principle. This provides a signal to the control module if a proper flame exists.

l. Air Temperature Sensor

This is a thermocouple sensor for monitoring the ambient air temperature. The flexible magnetic end of the sensor should be placed so it is shaded by the GHAB unit, generally on the north side.

m. Rail Temperature Sensor

This is a thermocouple sensor for monitoring the actual rail temperature.

n. Gas Valve

These are electric solenoid valves which control the flow of gas for burner operation. It is controlled directly from the control module.

o. Blower Motor

The motor is totally enclosed and fan cooled.

p. Blower

The high efficiency blower wheel is dynamically balanced for smooth and quiet operation.

q. Buzzer

The buzzer will sound a 10-second tone immediately before the motor contactor is energized.

3.2. Standard Ductwork

**DO NOT WALK ON EQUIPMENT. THIS
INCLUDES TRACK DUCTS AND
FIBERGLASS COVERS.**

a. Heat Duct

The first section of ductwork attached to the main HAB unit. This duct contains the burner, air flow switch, spark igniter and the duct pressure sensor.

b. Flex Duct

Connects the heat duct to the offset duct. It is a section of flexible duct, enclosed in an insulated sheet metal wrapper.

c. Heavy Duty Offset Duct

Connects the flex duct to the tie outlet duct. This duct provides an 8” offset and encloses the air mixer.

d. Tie Outlet Duct

The outlet duct extends under the rails in place of a tie and directs the airflow to the point nozzles and track ducts. The rail attaches to the duct using tie plates and E clips. The tie plates are electrically insulated from the rail using an insulating kit. There are six openings in the top for point nozzles and track duct nozzles. Refer to the drawing page for the duct layout.

e. Track Ducts

These ducts rest on brackets on the ties and the outlet duct. They are installed over the track duct nozzles. The track ducts consist of a 5’ point, a 5’ mid, and 10’ sections to complete the desired length.

f. Track Duct Nozzle

This attaches to the inner two rectangular openings on the top of the outlet duct. This directs airflow down the length of the switch through the track ducts.

g. Track Duct Nozzle Isolating Kit

This is an electrically insulating gasket with insulating washers and hardware to provide isolation between the nozzles and the outlet duct. Refer to drawing 9278-0027 for proper installation.

h. Quick Change Nozzle Plate

This plate allows for quick removal or installation of nozzles to the tie duct, by simply loosening of four bolts the nozzle assembly can be removed or installed.

i. Track Duct Support Bracket

These brackets are used to secure the track duct in position. Refer to drawing 92774.

j. Switch Point Nozzle

These nozzles direct heated air down the switch point. They are mounted on the outlet duct. They can be adjusted for proper airflow direction. Nozzles may be shortened by up to 10” for proper fit.

k. Point Nozzle Isolating Kit

This is an electrically insulating gasket with insulating washers and hardware to provide isolation between the nozzles and the outlet duct. Refer to drawing 9278-0021 for proper installation.

3.3. Optional Ductwork

a. Extension Ducts

Extension ducts of various lengths are available to meet specific requirements. These are insulated and enclosed in a metal wrapper. Make sure the duct is mounted in the correct orientation, as there is an access opening underneath the insulating wrapper cover. If additional duct extensions are required, this assembly can be added between the outlet duct and the offset duct.

b. 7’ Track Duct

These track ducts are seven feet long. They are often mounted outside of the track near the switch machine. A kit is available (P/N 9278-0270) that includes a 7’ track duct, a track duct nozzle and a track duct isolation kit.

NOTE: OTHER DUCTWORK ASSEMBLIES ARE AVAILABLE. CONSULT THE FACTORY FOR SPECIAL DUCTWORK NEEDS.

4. Installation

**DO NOT WALK ON EQUIPMENT. THIS
INCLUDES TRACK DUCTS AND
FIBERGLASS COVERS.**

NOTE: The installation should be done in this order:

1. Tie Duct Outlet Duct/Offset Duct
2. Main HAB Unit/Flex Duct
3. Point Nozzles and Track Duct
4. Gas
5. Changing the Gas Orifice
6. Electrical

**PLEASE READ THROUGH THE ENTIRE
INSTRUCTIONS BEFORE BEGINNING THE INSTALLATION**

4.1. Tie Duct

1. Remove the appropriate tie. Choose the tie that will result in the point nozzles being as close to the switch point as possible without interfering with normal switch operation. The distance from the center of the tie duct to the end of the point nozzles is 33". If necessary, up to 10" may be cut off each point nozzle.
2. Remove sufficient ballast to provide at least 14" clearance from the bottom of the rails.
3. Carefully slip the tie duct under the rails and position it so that the rails are directly above the tie plates. Ensure that the tie duct is centered between the adjacent ties.
4. Place a rubber pad on the tie plate, then using a suitable lever, raise one end of the tie duct until the rail lies correctly on the pad on the tie plate. Place two e-clip insulators, one on each side of rail, in place and then fasten the rail to the tie plate using two of the four 927248 rail clips. Use a heavy hammer or maul to drive the clips securely into place.
5. While keeping the tie duct supported in place, firmly pack ballast under the tie duct from the rail out to the end.
6. Repeat steps 4 and 5 for the other end of the tie duct.

7.
 - i. Remove the end flange plate nearest the HAB by loosening the six retainer bolts.
 - ii. Install the two-foot heavy duty offset duct (P/N 9278-3402) to the tie duct using hardware and gasket supplied with the offset duct.
8. Firmly repack ballast under the entire tie duct.

4.2. Main HAB Unit

1. The main HAB unit has four slotted mounting holes on 15-1/2" x 34-1/2" centers.
2. Refer to Foundation Assembly drawing for the assembly of the optional mounting foundation.
3. Use the provided GHAB positioning drawings to determine the approximate position and height of the mounting foundation. The top of the foundation should be placed 4"-6" below the height of the ties. This will allow final adjustment of the HAB unit.
NOTE: The drawing shows a standard HAB unit, but can be used for the low profile series, also.
4. Excavate and place the foundation in its proper location.
5. Refer again to the drawing of the Foundation Assembly, detail A, showing the mounting bolt arrangement. Attach four 3/4-10 x 8" hex bolts in the slotted holes of the blower base, using a washer on each side of the blower base and a hex nut.
6. Thread a hex nut about halfway onto each bolt.
7. Place the blower unit on the foundation using a flat washer on the top and bottom of the foundation and another hex nut on the bottom. The slotted holes in the foundation will allow for side-to-side adjustment, and the slotted holes in the HAB base will allow front-to-back adjustment. However, do not tighten the mounting nuts yet.
8. Install the 30" flex duct onto the HAB flame duct.

- 9.** Now adjust the HAB unit side to side, up or down, and forward or backward to obtain the proper alignment of the heat duct to the offset duct. It may be necessary to adjust the position of the offset/outlet duct assembly. The adjustments should be made so that there is no stress on any of the ductwork; also flex duct should measure 30". Again, leave the mounting nuts loose for now.
- 10.** Connect the other end of the flex duct to the HD offset duct.
- 11.** With all components in the proper position, the foundation nuts may now be tightened.
- 12.** The fill can now be replaced around the mounting foundations.
- 13.** Adjustable air intake screens. To start the GHAB in a new location, set the intake screens in the closed position. If there is a moisture problem, where frost builds up on the intake screens, the intake screens can be set in the open position to improve the airflow into the blower.

4.3. Point Nozzles and Track Ducts

NOTE: Refer to the GHAB positioning drawing for the track duct and point nozzle position. LH and RH Point/Track Nozzle Assemblies:

1. Attach point/track nozzle assembly RH (P/N 9508-4000) and point/track nozzle assembly LH (P/N 9508-4001) to the openings in the tie duct. Position assemblies for proper airflow direction.
2. Assemble the individual track duct sections into two complete track duct sections. The mid and heel sections contain splices wrapped around the outside of the duct. Unhook the clips to remove the three cover pieces. The bottom can now be removed from the duct.

NOTE: To assemble the splice:

- i. Center the bottom splice piece on the seam between the two track ducts.
 - ii. Connect the center cover piece over the seam. (**NOTE:** The center cover piece has slots to contain the bolts on the track duct).
 - iii. Finally, connect the two end cover pieces.
3. Lay the track ducts on the rail ties alongside where they will be installed.
4. Refer to the drawing 92774. Place the track duct support brackets in position on the ties so that one is near the heel end and one near each joint. Use the lag bolts to fasten the brackets in place. Lay the track duct on the bracket bases. Place the hold-down straps over the track ducts. Attach the hold-down strap to the track duct support brackets by inserting the spring clip into the strap.
5. Push in the square knockouts in the track ducts where airflow is desired. The knockout should be pushed in and bent completely so that no portion of the knockout obstructs the airflow in the duct. Knockout tabs that are not bent back completely will obstruct the airflow as it moves through the track duct resulting in reduced air pressure and airflow further along the track duct.

4.4. Gas Connection



CAUTION

When tightening gas line fittings or components to the HAB unit, be sure that you do not rotate the pipe that enters the blower unit. This could cause the gas control valve inside the blower unit to rotate also. Please reference the label attached just above the pipe that enters the blower unit.

NOTE: Optional items available from Railway Equipment Co. are denoted by *

1. The following items are shipped in a carton marked "GAS LINE ACCESSORIES", along with various pipe fittings, so that they may be arranged to fit the particular installation. Refer to Instruction Sheet R9500-0027 included with Gas Line Accessories for the proper placement of these components:
 - Flexible pipe
 - Y strainer (s)
 - Manual shutoff valve
 - Low pressure regulator
 - Regulator Spring, if included

2. The following items are available as optional items:
 - * High Pressure Regulator (P/N 45103)
 - * 36" Gas tank "pigtail" (P/N 60127)
 - * 12" Gas tank "pigtail" (P/N 45038)
 - * Remote gas valve (P/N 45036)

NOTE: A propane package is available (P/N 9458-0100) that includes a 36" tank pigtail, high pressure regulator, gas line strainer, gauge, remote solenoid valve in a pole mount enclosure, and a 4X4X8' post.

FOR NATURAL GAS INSTALLATION PROCEED TO STEP 5

3. * Install the copper "pigtail" to the propane tank. Each end of the pigtail is a reverse thread.

4. * Install the high pressure (red) regulator to the pigtail. Remember reverse thread on the pigtail connection.

5. Install the "Y" strainer downstream (but near) the high pressure regulator, or natural gas source.

6. * Install the remote gas valve downstream (but near) the "Y" strainer. Electrical connections from the remote gas valve are made to terminal posts TS1-10 (115VAC) and NEUTRAL on the HAB unit. The valve must be mounted with the inlet and outlet horizontal, and the coil upwards.
7. Install adequate size gas pipe from the remote tank location to the main HAB unit. Check with local gas supplier for sizing recommendations.
8. The remaining gas line components are attached to the HAB unit, as shown on the drawing, layout, GHAB Gas Line. Remember to position the regulator vent fitting facing sideways so that moisture will not enter the regulator.
9. If you are having problems adjusting the gas pressure low enough on 3 HP units, the spring in the low pressure regulator must be changed. To change the spring, complete the following steps:
 - i. Try adjusting the low pressure regulator for proper fuel pressure. If it can't be adjusted, follow instructions listed below for changing the regulator spring.
 - ii. Turn power off and close manual gas valve.
 - iii. Remove the plug on top of the regulator.
 - iv. Turn the plug inside the regulator counter-clockwise until it can be removed.
 - v. Replace the red spring with the violet spring provided in the gas accessory kit.
 - vi. Replace the top plug.
 - vii. Go to gas pressure menu to adjust.

FOR INSTALLATION ABOVE 2000 FOOT ELEVATION:

- i. Turn the manual gas valve to "ON" position and turn power on.
- ii. Push the "LOCAL" button.
- iii. Place the burner control select in the hi-only position.

- iv. After the 30-second pre-purge period, the unit will ignite. Check the gas pressure display. Adjust the white plug in regulator until the display reads 11” water column for propane or 7” water column for natural gas.
NOTE: Clockwise to increase pressure, counter-clockwise to decrease pressure.
- v. Let the GHAB run for a 10 minute period.
- vi. After the 10 minute period, take temperature readings at both point nozzles.
- vii. Determine the ambient temperature at the location and subtract the ambient temperature from the point nozzle reading. This temperature should not exceed 250°F for optimum efficiency.
- viii. If the temperature is above 250°F, adjust the gas pressure at the low pressure regulator down (1” w.c. at a time) until you reach the desired temperature.
- ix. Replace the top plug.

FOR INSTALLATION BELOW 2000 FOOT ELEVATION:

- i. Turn the manual gas valve to “ON” position and turn the power on.
- ii. Push the “LOCAL” button.
- iii. Place the burner control select in the hi-only position.
- iv. After the 30-second pre-purge period, the unit will ignite. Check the gas pressure display. Adjust the white plug in regulator until the display reads 11” water column for propane or 7” water column for natural gas.
NOTE: Clockwise to increase pressure, counter-clockwise to decrease pressure.
- v. Let the GHAB run for a 10 minute period.
- vi. After the 10 minute period, take temperature readings at both point nozzles.

- vii.** Determine the ambient temperature at the location and subtract the ambient temperature from the point nozzle reading. This temperature should not exceed 250°F for optimum efficiency.
- viii.** If the temperature is above 250°F, adjust the gas pressure at the low pressure regulator down (1" w.c. at a time) until you reach the desired temperature.
- ix.** Replace the top plug.

4.5. Changing the Gas Orifice

1. This unit uses an orifice plate instead of individual orifices. The orifice plate contains the orifices for both propane and natural gas for both stages of operation.

CAUTION

2. Make sure the main circuit breaker is in the OFF position and the manual gas valve is closed before working on the HAB unit.
3. Remove the bottom intake cover from the HAB unit.
4. On the right hand side of the gas assembly you will see the orifice plate. The orifice plate has a tab facing out that says NG for natural gas or LP for propane. This will tell you how the unit is currently set up.
5. To change from one fuel to the other:
 - i. There are four bolts on each gas coupling plate. You need to fully remove the top two bolts on each coupling plate and you need to back out the bottom two bolts on each coupling plate 1/2 to 3/4 of an inch.
 - ii. On the inlet (left hand side of the gas assembly) you need to remove the two bolts securing the gas valve assembly to the outside of the GHAB, and loosen the U-bolt.
 - iii. You can now carefully slide the gas assembly to the left to free the orifice plate.
 - iv. The orifice plate can be pulled away from the outlet manifold and then up and out.
NOTE: Take care removing the orifice plate so you don't damage the O-rings.
 - v. The orifice plate can now be flipped over for the other fuel and re-inserted in between the gas coupling and outlet manifold.
NOTE: Take care replacing the orifice plate so you don't damage the O-rings.
 - vi. Slide the gas assembly back to the right and insert the top bolts on the coupling plates.

- vii.** Verify the tab facing out on the orifice plate is now the correct fuel.
 - viii.** Evenly tighten the eight bolts on the coupling plates.
 - ix.** Replace the bolts on the inlet bracket (outside of GHAB), and tighten the U-bolt hardware.
 - x.** Re-install the lower intake cover.
- 6.** Turn on power and manual gas valve.
- 7.** Test unit and check regulator adjustment and output temp.

4.6. Electrical Connection

a. Knockouts

There are knockouts on the side and bottom of the control enclosure for incoming electrical wires.

b. Incoming Power

The incoming power should be connected directly to the main circuit breaker.

SPECIAL NOTE FOR 3 PHASE UNITS ONLY

WHEN THE MAIN HOT AIR BLOWER UNIT IS STARTED FOR THE FIRST TIME, VERIFY THAT THE MOTOR IS TURNING IN THE CORRECT DIRECTION. TO DO THIS, REMOVE THE BOTTOM AIR INTAKE COVER AND CHECK TO SEE IF THE FAN IS ROTATING IN THE CCW DIRECTION. THERE WILL BE AN ARROW SHOWING THE CORRECT ROTATION DIRECTION. IF THE FAN IS NOT ROTATING IN THE CORRECT DIRECTION, SWAP 2 OF THE INPUT WIRES.

c. Ground

The chassis ground TS1-G should be tied directly to earth ground.



CAUTION

THE 230 / 480 / 575 VAC SUPPLY LINES SHOULD BE SIZED TO ALLOW FOR THE AC MOTOR START-UP CURRENT. REFER TO THE SPECIFICATIONS PAGE FOR START-UP CURRENT. UNDERSIZED CONDUCTORS OR LONG WIRE RUNS COULD DAMAGE THE MOTOR.

SPECIAL NOTE: THE CONTROL CHASSIS AND THE REST OF THE MAIN HAB UNIT MUST BE CONNECTED TO GROUND. THE RUBBER PAD BETWEEN THE RAIL AND TIE PLATE ALONG WITH THE E-CLIP INSULATORS WILL INSULATE THE MAIN UNIT FROM THE TRACKS.

d. Control Input

Remote operator control can be provided by a circuit closure applied between terminal posts TS1-1 and TS1-2.

e. Indication

Reply indication can be done two ways:

- i. Dry contact closure: Terminal posts TS1-3 and TS1-4 will provide a dry contact closure for indication when the unit is operating under remote control.

- ii. +24 VDC: Place a jumper between terminal posts TS1-2 and TS1-4. +24 VDC indication is now present on post TS1-3 with common at terminal post TS1-6.

f. Fail

Reply fail can be done two ways:

- i. Dry contact closure: Terminal posts TS1-5 and TS1-4 will provide a dry contact closure for fail when the unit is in a fault mode.
- ii. +24 VDC: Place a jumper between terminal posts TS1-2 and TS1-4. +24 VDC fail is now present on post TS1-5 with common at terminal post TS1-6.

g. Duct Work High Temperature Sensor (P/N 9338-0355)

- i. On the tie duct, remove the two bolts holding down the overtemp sensor cover. Install the sensor onto the duct using the two bolts that were removed.
- ii. Run conduit along duct work back to HAB enclosure; connect connector to enclosure knock out; tighten (**NOTE:** Cut conduit to length if needed).
- iii. Run wires from sensor into enclosure and plug connectors into OVERTEMP (RED) J10 and OVERTEMP (BROWN) J36 located on the control module.
- iv. Use two clamps (P/N 60086) to secure conduit to the side of duct work using existing screws.

<p>CAUTION DO NOT INSTALL OVERTEMP SENSOR ON FLEX DUCT.</p>
--

h. Rail Temp Sensor (P/N 9508-0415)

- i. Attach the sensor to the bottom of the stock rail in front of the point nozzle. Attach conduit to ties using the provided clamps.
- ii. Run wires from sensor into enclosure and plug connector into THERMOCOUPLE CONNECTIONS RAIL TEMP (YELLOW) located on the control module.

5. Control Module

5.1. Description

The hot air blower control module contains all of the elements and functions necessary for advanced snow melter operation. The unique dual-chip microcomputer has been programmed with logic and timing sequences to provide complete heater control as well as operational control and system interface. Some of the many features included in the control module are:

- Auto-Off-Local selector switch
- Adjustable air temperature setting
- Built-in snow detector (Requires Optional Snow Detector Head)
- Adjustable start-up delay sequence
- Adjustable run timer for timed or continuous operation
- Adjustable snow detect timer for use with optional snow detector
- Operator control and indication
- Remote fault reset
- Audible tone before blower start-up
- Input/output status indication lights:

Inputs:

- Air temperature
- Remote Control
- Moisture Detector One or two snow detector(s) (Optional)
- Airflow switch
- Flame Sensor

Outputs:

- Blower motor
- Ignition
- Hi Gas valve
- Low Gas valve
- Indication
- Fail



Flame safety control:

10 second tone before blower turn on

Air flow proving

30 second pre-purge before ignition

Direct spark ignition

10 second maximum ignition period before lock-out

Rectification type flame rod sensor

Automatic retry on flame loss

4 minute post-purge period after gas valve turn-off

Automatic reset

Fault if flame does not go out after gas valve is commanded off

5.2. Set-Up and Adjustments

To change settings and adjust times do the following:

Right Arrow Button

Pushing the right arrow button will cycle forward through the menus. Each time you press the right arrow button you will advance one menu selection.

Left Arrow Button

Pushing the left arrow button will cycle back through the menus. Each time you press the left arrow button you will move back one menu selection.

Up Arrow Button

The up arrow button allows you to increase values and switch through menu categories.

NOTE: Values will be saved.

Down Arrow Button

The down arrow button allows you to decrease the values and switch through menu categories.

NOTE: Values will be saved.

NOTE: After you are have finished changing the settings / values and you do not touch any of the buttons for 15 seconds, you will see the following screen. This screen just lets you know that your current settings and values are being saved.



5.3. Password 0 and 5 Menus

NOTE: The following items listed below are for password 5. Password 0 has the same set of menu categories but does not have all the same menu selections in each category. It will be denoted which menu selections you can only see with password 5

The controller has 4 menu categories, they are:

1. Status
2. Factory Defaults
3. Set Points
4. Faults History

5.3.1. Status

a. Outside Temp and Preset Value

Displays the current ambient temperature and temperature preset value. If the ambient temperature is below the preset value, the unit will start if requested.

b. Gas Pressure and Duct Pressure

Gas pressure is the actual differential pressure at the burner. The unit of measure is inches of water ("H₂O). To view gas pressure, the burner should be burning. The correct setting should be approximately 11"H₂O for propane and 7"H₂O for natural gas. While adjusting, the burner should be in high only. Adjust regulator to change gas pressure value. Duct temperature is the actual duct temperature in degrees F or C.

c. Rail Temp and Duct Temp

Rail temperature is the actual rail temperature in degrees F or C. Duct temperature is the actual duct temperature in degrees F or C.

d. Total Gas and Reset Gas

(Password 5)

Total gas displays the calculated amount of gas that has been used. The unit of measure is gallons if propane is selected. The unit of measure is cubic feet if natural gas is selected. Reset gas is the same as total gas except it can be reset. To reset, press the down button.

e. Hours Meter and Reset Hour

(Password 5)

Hour meter displays the total hours that GHAB has been running. Reset hour is the same as hour meter except it can be reset. To reset, press the down button.

f. Tank Level, Bat and Temp

Tank level displays the actual level of propane tank in percent full (optional tank level monitor must be installed). Bat displays the battery level of the tank monitor. Temp displays the temperature in the battery monitor.

g. Name

(Password 5)

This screen tells the name you have entered for the unit.

5.3.2. Factory Defaults

Factory default is used to place all parameters back to factory default settings. To restore to factory default, select FACTORY DEFAULTS in the menu selection. Press the right arrow button to display “FOR FACTORY DEFAULTS PRESS DOWN BUTTON,” then press the down arrow button to restore factory defaults.

5.3.3. Set Points

a. Password

A password is needed to access the advanced menus. To enter in the password, use the up or down arrow buttons. Password 5 allows advanced menu items to be changed.

b. Select Temperature Setpoint

The ambient temperature below which the unit will energize is set on this screen. When the outside temperature is below this setpoint, the unit will be allowed to operate if requested. The factory default is 38°F (3°C). The range is from 0°F to 100°F (-18°C to 38°C).

c. Select Run Timer Value

The run timer can be set from 0 to 1000 minutes. If zero is selected, the outputs will operate continuously, until control on is disabled. If another value is selected, the unit will run until the run timer counts down to zero, after which the unit will shut down and drop indication. The unit can be restarted by removing the contact closure between TB2-1 and 2, then reinstalling it. If Run Timer Pulse Mode is activated, the minimum run time value is 10 minutes. The factory default setpoint is 60 minutes.

d. Select Snow Timer Value

The snow timer can be set from 10 to 1000 minutes. The snow time starts counting down when the moisture detector no longer sees snow. The factory default setpoint is 60 minutes.

e. Select Snow Sensor Speed

Snow sense speed sets the delay time after the moisture detector sees moisture and starts the snow cycle. The delay time can be set from 1 to 60 seconds. The moisture sensor must see moisture for entire time to start cycle.

f. Select Snow Indication

(Password 5)

The choices are OFF or ON. With snow indication off, indication will remain off during snow time if no faults are present. With snow indication on, indication will remain on during snow time if no faults are present.

g. Select Fault Indication

(Password 5)

The choices are OFF or ON. With fault indication off, indication will remain off if faults are present. With fault indication on, indication will remain on if faults are present.

h. Select Start Delay Value

(Password 5)

The start delay timer can be set from 0 to 250 seconds in 10 second increments. It is used to delay the start of GHAB so when several blowers are at the same location they do not start at same time.

i. Select Burner Operation

The choices are LOW, HIGH, AUTO, and AUTO OFF:

- LOW - 50% BTU output of Hi with or without the rail sensor.
- HIGH - 100% BTU output with or without rail sensor.
- AUTO - Switches between high and low dependent on the rail & duct temperature sensor and setpoint.

NOTE: If no rail sensor is connected, it will run at low (50% output). Units with only single stage installed, should select high only.

- AUTO OFF - When rail temperature reaches the rail temp setpoint, the GHAB will shut down. When the rail temperature lowers to the ambient temperature setpoint, the GHAB will start again.

j. Operation Mode

(Password 5)

The choices are NATURAL, PROPANE, COLD AIR, COLD AIR/PROPANE, and COLD NATURAL:

- NATURAL - The GHAB's burner is fueled by natural gas.
- PROPANE - The GHAB's burner is fueled by propane.
- COLD AIR - The GHAB will turn its blower on with air temperature. It will not use a burner.
- COLD AIR/PROPANE - The GHAB will turn its blower on with air temperature. It will then turn its propane burner on with moisture or control.
- COLD AIR/NATURAL - The GHAB will turn its blower on with air temperature. It will then turn its natural gas burner on with moisture or control.

k. Select Motor Size

The choices are:

2 HP 230V 1PH, 3 HP 230V 1PH, 5 HP 230V 1PH,
2 HP 460V 3PH, 3 HP 460V 3PH, 5 HP 460V 3PH,
2 HP 575V 3PH, 3 HP 575V 3PH, 5 HP 575V 3PH,
2 HP 3PH Drive, 3 HP 3PH Drive, 5 HP 3PH Drive
2 HP 230V 3PH, 3 HP 230V 3PH, 5 HP 230V 3PH

l. Rail Temp Setpoint

This can be set from 0°F to 280°F (-18°C to 138°C).

m. Duct Temp Setpoint

This can be set from 150°F to 250°F (66°C to 121°C).

n. Local With/Without Air Temperature

(Password 5)

Sets the local feature to, or not to, be dependent on the air temperature.

o. Remote With/Without Air Temperature

(Password 5)

Sets the remote feature to, or not to, be dependent on the air temperature.

p. Auto Overtemp Reset

(Password 5)

Auto overtemp reset will reset the overtemp once it has been triggered.

q. Select F or C

(Password 5)

Sets the temperature scale to either Fahrenheit or Celsius.

r. My IP Address

This is the IP address for your GHAB unit.

s. Machine S/N

(Password 5)

Machine serial # is the serial number of the whole GHAB unit.

t. Program Rev and Date

(Password 5)

Shows the program revision and the date it was compiled.

5.3.4. Fault History

NOTE: Some faults may not show in Fault History until there is an actual fault. Press the up or down arrow button to reset fault count.

a. Flame Loss and Flame On

Flame loss counter is total count of flame loss faults. Flame on counter is total count of flame on faults.

b. Sail Loss and Sail On

Sail loss counter is total count of sail loss faults. Sail on counter is total count of sail on faults.

c. Motor Current and Comm Reset

Motor current fault is total count of motor current faults. Comm reset fault is total count of communication reset faults.

d. Motor V Fault and Overload

Motor volts low or high counter. Overloads counter is total motor overloads faults.

e. Gas Valve Leak and Pressure Fault

Gas valve counter is total count of leaking gas valve faults. Gas pressure low or high counter.

f. Duct Pressure Fault and Vap. Press Low

Duct pressure fault counter is total count of duct pressure faults. Vaporization low fault counter is total count of vaporization low faults.

g. Gas Level

Informs if the gas level is low or high.

h. Over Temp Warning Counter

Counts the total number of Over Temp warnings.

i. Auto Overtemp Reset Counter

Counts the total number of times the Over Temp was reset.

j. Power Up Counter

(Password 5)

Counts the number of times the module has been powered up.

k. Status Log

Shows the status log history.

5.4. Push Buttons and LED Status Indicating Lights

5.4.1. Push Buttons

a. Auto

This position will allow operation by placing a circuit closure across terminal posts 1 and 2. It will also allow operation by an optional snow detector.

b. Off

If off, GHAB cannot be run from remote or snow detector.

c. Local

If LOCAL without air temp parameter is enabled, pushing the LOCAL button enables the snow melter regardless of outside air temperature. The snow melter will remain on until LOCAL is turned off. This is useful for hot weather testing.

5.4.2. Led Status Indicating Lights

a. Air Temperature

On when the ambient air temperature is below set point.

b. Moisture Detector

On when the optional snow detector sensing head(s) senses moisture.

c. Remote Control

On when there is a circuit closure across terminal posts 1 and 2.

d. Blower

On when the controller has turned on the output to the blower motor contactor.

e. Air Flow

On when the sail switch in the air stream is sensing adequate airflow.

f. Ignition

On when the controller has enabled the output to the ignition transformer.

g. Hi Gas Valve On

On when the controller has enabled the output to the high gas valve.

h. Low Gas Valve On

On when the controller has enabled the output to the low gas valve.

i. Flame Sensor

On when the flame sensing determines that there is proper combustion.

j. Indication

On when there is a circuit closure across terminal posts 1 and 2 and the unit is operating, or the air temperature is above the set point. Also may be on when there is a fault condition under snow detector.

k. Fail

This LED is on whenever a fault is present.

5.5. Operation

With AUTO selected, the unit can be activated by applying a circuit closure between terminals TS1-1 and 2. If the outside temperature is above set point, the unit will not start a snow melt sequence, but will turn on the indication LED. It will provide a relay contact closure between TS1-3 and 4 to indicate to the remote station that the unit is operational. If the “REMOTE WITHOUT AIR TEMP” parameter is set, the temperature sensor will be overridden, and a contact closure will start a snow melt sequence even if the air temperature is above the set point.

If a circuit closure exists between TS1-1 and 2, and the air temperature is below set point, the unit will begin a snow melt sequence. The unit executes a 0 to 300 seconds time delay depending on the setting of the START DELAY TIMER. Then, a 10 second audible tone sounds as a warning that the blower motor is about to turn on.

The airflow switch is checked to see if it is closed. If it is, the blower will display SAIL SWITCH ON FAULT.

If the airflow switch is open, the motor will turn on. After the blower motor is turned on, the airflow switch is monitored. It closes if airflow is normal. If it does not close within 10 seconds (or 30 seconds for an AC drive) after blower turn-on, the blower displays SAIL SWITCH OFF FAULT. When the airflow switch closes, a 30 seconds pre-purge time will start. After the pre-purge time is completed the gas valve opens, the ignition turns on and the burner is monitored for a normal flame condition. If a flame is not detected within 10 seconds, the gas valve is closed, the ignition spark is removed and the blower displays NO FLAME DETECTED FAULT.

If a normal flame condition is detected the “indication” contact closure is established between TS1-3 and 4. The unit will run for a period of time determined by the setting of the RUN TIMER. If the run timer is set at “0” the unit will continue to run until the circuit closure between TS1-1 and 2 is removed.

If the blower is equipped with the two stage gas valve option and the rail temp sensor is installed, then under normal operation when the rail reaches the preset temperature setting, the low gas valve will open and the high gas valve will close. This will result in a fuel reduction of 50%. When the rail falls below the programmed temperature, the high gas valve will open and the low gas valve will close resulting in the burner returning to 100% capacity.

If the blower is equipped with the two stage gas valve option and the duct temp sensor is installed, then under normal operation when the duct reaches the preset duct temperature setting, the low gas valve will open and the high gas valve will close. This will result in a

fuel reduction of 50%. When the duct falls below the programmed temperature, the high gas valve will open and the low gas valve will close resulting in the burner returning to 100% capacity. If the duct temp sensor sees a temperature above 325°F (163°C) both gas valves will be disabled. This prevents over temps.

There is a burner control adjustment available in the control module adjustments that allow the burner to be set to high only, low only or automatic controlled by the rail temp sensor. If the two-stage option is not installed, the burner control switch should be set to high only. Refer to section 5.3.3 Select Burner Operation.

SNOW DETECTOR OPERATION: If the unit is operating with one or two optional snow detector assemblies and moisture is detected by either (or both), a snow melt sequence will begin, provided that the air temperature is below the set point. The unit will start as described in section 5.3.3 Select Snow Timer.

5.6. Fault Conditions

a. Sail Switch On Fault

During startup the processor checks the status of the airflow switch. If the airflow switch is closed or shorted the blower motor will turn on and the blower will run a 4-minute purge to try to clear the airflow switch. The motor will then shut off and sit idle for 1 minute. Upon completion of this 5-minute cycle, the blower will once again check the airflow switch for proper operation. If the airflow switch still shows that it is closed, it will run the 5-minute loop again. This will repeat until fault is cleared or blower is no longer called for.

b. Sail Switch Off Fault

Sail switch off fault is set when blower is running and air flow switch is open. After the fault is set the blower motor will run a 4-minute purge to try to clear the airflow switch. The motor will then shut off and sit idle for 1 minute. Upon completion of this 5-minute cycle, the blower will once again check the airflow switch for proper operation. If the airflow switch still shows that it is open it will run the 5-minute loop again. This will repeat until fault is cleared or blower is no longer called for. Check to see if the sail switch is free to move and if there are any obstructions in duct work.

c. No Flame Detected Fault

No flame detected fault is set when blower is running and air flow switch is closed with gas valve open. If no flame is detected within 10 seconds the fault will be set. After the fault is set the blower motor will run a 4-minute purge to try to clear the flame rod. The motor will then shut off and sit idle for 1 minute. Upon completion of this 5-minute cycle, the blower will once again check the flame rod for proper operation. If no flame is present it will run the 5-minute loop again. This will repeat until fault is cleared or blower is no longer called for. Check to see if the flame rod is shorted to ground, the flame rod is loose, the flame rod is dirty or if the insulators is fully installed so that no moisture can short out the flame rod.

d. Flame Detected On Fault Gas Valve Failure

Flame detected on fault is set when blower is running and air flow switch is closed with gas valve closed. If flame is detected before gas valve is opened the fault will be set. The blower will continue to run and buzzer fail indication will be set. The circuit breaker must be power cycled to clear this fault. Check to see if the flame rod is shorted to ground, the flame rod is loose, the flame rod is dirty or if the insulators is fully installed so that no moisture can short out the flame rod.

e. Gas Valve Failure

During the blower shutdown operation if the unit senses flame after the post-purge, the unit will not shutdown. Instead it will go into gas valve failure mode. In this mode the blower continues to run, the reply will also indicate a problem, and the buzzer will sound. The unit will lock out all other operations and will not be able to be reset except at the unit itself.

f. Check Fuse #1 24 VDC Power

Fuse #1 is tripped. Check the following circuits:

- Overtemp switch and wiring.
- Check TS1-2 +24 control on wiring.
- After problem is corrected, leave power off for 30 seconds and fuse will reset.

g. Check Fuse #2 Ignition Transformer

Fuse #2 is tripped. Check the following circuits:

- Ignition transformer and wiring.
- After problem is corrected, leave power off for 30 seconds and fuse will reset.

h. Check Fuse #3 Gas Valve / Sail Switch

Fuse #3 is tripped. Check the following circuits:

- Check sail switch and wiring.
- Check hi and low gas valve and wiring.
- Check external gas valve and wiring.
- After problem is corrected, leave power off for 30 seconds and fuse will reset.

i. Check Fuse #4 Blower Motor

Fuse #4 is tripped. Check the following circuits:

- Check blower motor contactor and wiring.
- After problem is corrected, leave power off for 30 seconds and fuse will reset.

j. Check Fuse #6 Snow Head #1

Fuse #6 is tripped. Check the following circuits:

- Check snow detector head #1 and wiring.
- Check gas pressure sensor and wiring.
- Check duct pressure sensor and wiring.
- After problem is corrected, leave power off for 30 seconds and fuse will reset.

k. Check Fuse #7 Snow Head #2

Fuse #7 is tripped. Check the following circuits:

- Check snow detector head # 2 and wiring.
- Check sail switch and wiring.
- After problem is corrected, leave power off for 30 seconds and fuse will reset.

l. Check Fuse #10 Pressure/Bat Charger

Fuse #10 is tripped. Check the following circuits:

- Check pressure sensor.
- Check 24V supply for battery backup.
- After problem is corrected, leave power off for 30 seconds and fuse will reset.

m. Overtemp Fix Problem Press Decrease

Overtemp sensor has tripped. If the temperature inside the Tie duct exceeds 375°F, it will cause the ductwork overtemp circuit to trip, shutting down the HAB system. Only pushing the down arrow button will reset the unit, giving opportunity to check the cause of the overtemp condition.

n. Overtemp Fix Problem Press Decrease ___ Min

The overtemp sensor has tripped. The HAB system will shut down for some time period then it will reset the unit. **NOTE:** AUTO OVERTEMP RESET must be enable in order to see this fault.

o. Overtemp Warning Restart In ___ Sec

If the temperature is close to overtemp value, the unit will restart in a certain time period.

p. Overtemp Missing Install Overtemp

Caused by missing overtemp sensor.

q. Motor Voltage Low

Motor voltage low is caused by inadequate electrical service supply. During motor start up if motor voltage drops below 190VAC, the motor will eventually be damaged. If this under-voltage occurs, an error will be set. Press the down arrow button to clear the fault.

r. Motor Voltage High

Motor voltage high is caused by high motor voltage. It can also be caused by high voltage from the electric company.

s. Motor Overload, Reset Overload Device

High motor current will trip the motor overload on the control panel. This device is connected to the bottom of the motor contactor on the control panel. Reset by pressing the red button on the device. Check unit for high motor current, bad bearings, or obstructions in the blower wheel.

t. Motor Current Low

Caused by low motor current.

u. Motor Current High

Motor current high is caused when sensed current is 3 amps over motor name plate for 20 seconds. Check motor for high current, bad bearings, obstruction in blower wheel.

v. Gas Pressure Low

Gas pressure low is caused by supply gas pressure during operation dropping to a low level. Check gas delivery system.

w. Gas Pressure High

Gas pressure high is caused by high gas pressure going to the burner. Check gas delivery system. Adjust the regulator on the gas delivery system to lower the gas pressure.

x. Duct Pressure Low

Duct pressure low is caused by not enough duct back pressure. Possible causes are missing flame cover or missing duct work.

y. Duct Pressure High

Duct pressure high is caused by too much duct back pressure. Possible causes are duct work obstructions.

z. Propane Tank Low Warning Fill Tank

Propane tank low is caused by low propane tank level. **NOTE:** Propane tank level monitor must be installed and setup, for this warning to appear.

aa. Tank Vaporization Pressure Low Warning

Tank vaporization pressure low warning is caused by low tank temperatures.

bb. Utility Power Lost

Utility power lost is caused by no incoming AC voltage. There must be a battery backup in order to receive this fault.

cc. Additional Fuses

The control module has 4 additional fuses on the module that require replacement if they are open.

- **FUSE 5** (P/N 51179) FUSE, MINI 5 AMP is above the display and fuses the indication common on terminal 4.
- **FUSE 8** (P/N 51225) MDA 10 AMP is to the right of the display and fuses the 120VAC power to the module.
- **FUSE 9** (P/N 51209) FUSE, .5 AMP, is below the display and fuses the pressure sensors.
- **FUSE 11** (P/N 51179) FUSE, MINI 5AMP is in the top left corner of the control module. This fuse is in the 24VDC control on circuit.

NOTE: Remove the module cover to access F5, F8 and F9. F11 is visible with the cover installed.

6. Seasonal Maintenance

To perform seasonal maintenance on your GHAB units, please follow the steps below, depending on which season you are in.

6.1. Spring

1. Turn off gas source.
2. Turn off electric power at source.
3. Disconnect and remove the control module. Store in a clean, dry place.
4. Turn off manual gas valve.

6.2. Fall

1. Check all ductwork for clear airflow. Ensure that the point and track duct nozzle screens are not damaged and are completely covering the openings. Make sure that no debris or rodents have obstructed any area of the ductwork.
2. Inspect the track duct nozzles for proper operation.
3. Remove the flame duct cover. Check the burner. Make sure the spark igniter plug and flame rods are in good, clean condition. Check the wiring to make sure rodent or vibration have not damaged the insulation.
4. Check the airflow sail switch to make sure it is operating properly.
5. Replace the flame duct cover.
6. Install the control module and connect the wires.
7. Turn on the gas source.
8. Turn on the manual gas valve.
9. Turn on the electric power at source.
10. Perform the gas pressure regulator adjustment procedure as described on the following page of this manual.
11. Perform a flame failure test:
 - a. Push the LOCAL button.
 - b. Turn off the manual gas valve.
 - c. Turn on the main circuit breaker.
 - d. After 40 seconds (plus any start delay period) the fault message NO FLAME DETECTED FAULT should be displayed. If the fault does not appear, the control module is faulty and should be replaced.
12. Check the air temperature for proper setting.

7. Motor Greasing Procedure

Follow this procedure to properly grease the motor you have for your unit. This procedure is only for, if you have, a 3 HP gas hot air blower unit, a 5 HP gas hot air blower unit, or a cold air blower unit.

1. Before you begin the process of lubricating the bearings, please advise:
WARNING: Do not touch electrical connections before you first ensure that power has been disconnected. Electrical shock can cause serious or fatal injury.
WARNING: Surface temperatures of motor enclosures may reach temperatures which can cause discomfort or injury to personnel accidentally coming into contact with hot surfaces. Protection should be provided by the user to protect against accidental contact with hot surfaces. Failure to observe this precaution could result in bodily injury.
2. Once what is stated above in step one is taken into consideration and done, you now need to make should that you are in a stationary position to lubricate the bearings and that the motor is warm.
3. Locate the two grease Zerks at the top of each end of the motor and clean each Zerk. Cleaning is important to prevent any unwanted filth to be transferred into the motor.
4. Locate the weep holes on the bottom of the motor. Clean them to remove any unwanted grease or filth. These need to be clean in order to allow excess grease to leave the bearings.
5. Now select one of the Zerks to be used to add more grease into the motor.
NOTE: The correct grease to use for the motor is **Aeroshell 7**.
6. Attach a grease gun to one of the Zerks. Make sure you are using Aeroshell 7 and add a small amount of grease. It is recommended that you only squeeze the grease gun handle once or twice to satisfy the amount needed.
7. Remove the grease gun and allow the motor to run for 15 minutes to let out any excess grease from the weep holes.
8. After the 15 minutes, wipe the weep holes again if any excess grease is release and you are finished.

NOTE: You need to perform this greasing procedure every 5500 hours of use to make sure your motor is being maintained properly.

8. Low Pressure Regulator Adjustment/Output Temp Test

1. Push the LOCAL button.
2. Turn the manual gas valve to “ON” position and turn power on.
3. Place the burner control in the hi-only position. See section 5.3.3 Select Burner Operation.
4. After the 30-second pre-purge period, the unit will ignite. Check the gas pressure value by removing the regulator top plug. Adjust the regulator until the gauge reads 11” water column for propane or 7” water column for natural gas.
NOTE: Clockwise to increase pressure, counter-clockwise to decrease pressure.
5. Let the GHAB run for a 10 minute period
6. After the 10 minute period, take temperature readings at both point nozzles.
7. Determine the ambient temperature at the location and subtract the ambient temperature from the point nozzle reading. This temperature should not exceed 250°F for optimum efficiency.
8. If the temperature is above 250°F, adjust the gas pressure at the low pressure regulator down (1” w.c. at a time) until you reach the desired temperature.
9. Replace the top plug.
10. Return all switches to their normal operating position.

9. Troubleshooting

9.1. Unit Does Not Start

1. Check circuit breaker.
2. Check control fuse 11.
3. Check for 18VAC between the following points:
 - a. TS1-6 and TS1-7
 - b. TS1-6 and TS1-8
 - c. Change T1 control transformer if either measurement is incorrect.
4. Check for air temperature below set point.
5. Is the control module programmed for a start-up delay?
6. Monitor the fault display on the control module.
7. Turn the circuit breaker off, and then reset the motor overload relay. The motor overload relay is adjustable. It should be set for the motor name plate current.

9.2. Unit Does Not Maintain Operation

1. Check the fuel supply. Refer to section 8, step#4.
2. Check 230VAC and 115VAC from either leg to the center tap neutral (with the unit running). It must be within +10% to -10%.
3. Check the burner. The burner must be clean and free of carbon.
4. The flame rod should be clean and secure.
5. Check the wire from the flame rod to the control module for continuity. Pull the white plug connector on the lower right side of the control module. Use an Ohmmeter to measure continuity from the terminal of the flame rod to the white connector. The reading should be less than 50 KOhms.

9.3. Low Heat Level

1. Perform a regulator adjustment/output temp test refer to section 8.
2. Check the fuel supply.
3. Make sure the burner is clean.
4. Make sure the orifice plate is installed for the fuel being used.
5. Check the low pressure regulator.
6. Check to see if the burner control is on low only or if it is in auto and the Rail Temp Sensor setting is forcing it to low output.

9.4. Low Airflow

1. Check for obstructions in all ductwork and the air intake.
2. If there is frost buildup on the air intake screen, move the screen to the “open” position.
3. Check the voltage and current levels on the blower motor.
4. Make sure knockouts on the track duct are pushed all the way back in the track duct.
5. Check the spacing between the inlet cone and the blower wheel. The gap should be less than 1/16 of an inch.
6. Perform pressure switch adjustment.
7. Make sure the blower wheel is turning in the right direction.

9.5. Gas Valve



CAUTION

**CHECK THE AREA TO BE SURE THERE ARE NO
LINGERING GAS FUMES BEFORE DOING
ANYTHING WHICH MAY CAUSE A SPARK!**

1. Turn off gas to the blower.
2. Turn off power to the blower.
3. Check the gas valve for obstructions.
4. Check the gas valve for proper operation.

9.6. High Heat Level

1. Check for proper orifice installation.
2. Perform the low pressure regulator and Temp Test found in section 8.

10.Snow Detector

10.1. Snow Detector Installation

1. The snow detector sensing circuitry is contained within the control module. All that is required for snow detector operation is to connect the sensing head(s).
2. Either one or two sensing heads may be used.
3. Each sensing head has three lead wires; black, white, and green. Connect as follows:
 - a. Green: one or both connected to TS1-6
 - b. Black #1: connected to TS1-7
 - c. Black #2: connected to TS1-8
 - d. White: one or both connected to TS1-9

NOTE: Refer to the diagrams when connecting wires for the sensing heads. It is important to properly connect the sensing head wires. Improper connection of the sensing head wires may result in damage to the control module and/or the sensing head.

4. To operate more than one HAB unit from a HAB unit that is controlled by a snow detector(s), connect terminal posts #6 together and terminal posts #9 together (do not connect terminal post #6 to terminal post #9). When connecting snow detectors to more than one HAB unit, first connect one HAB. Then connect the snow detector to one more HAB. If the snow detector does not operate properly, exchange L1 and L2 on the newest HAB circuit breaker.

NOTE: BE SURE L1 AND L2 ARE DE-ENERGIZED BEFORE EXCHANGING THEM. Continue to add HABs to the snow detector in the same manner until all the desired HABs are connected. DO NOT EXCEED 200' CABLE LENGTH (18 AWG WIRE).

5. The sensing heads should be mounted in a vertical position.

NOTE: Experience has shown that positioning a snow detector sensing head in the switch area between the ties and between the switch point and the track duct is effective. A second sensing head is then placed away from the switch area, such as on a bungalow or pole.

10.2. Snow Detector Operation

NOTE: A snow detector sensing head only detects moisture. With temperature sensing capability, the HAB unit assumes moisture is due to snow when the air temperature is below set point. All operating functions are similar to remote operation with the following exceptions:

1. Indication

During normal operation under snow detector control, the indication contact across terminal posts 3 and 4 will not be closed.

2. Snow Detector Run Timer

During remote operation, if the snow detector senses moisture, the unit will operate according to the settings. The unit will then operate for the duration of the run timer setting.

3. Fault Condition

A fault condition under snow detector control will cause the indication contact across terminal posts TS-3 and TS-4 to close. To reset the unit after a fault condition, momentarily apply a circuit closure between terminal posts TS-1 and TS-2 with pushing the AUTO button. The unit may now be operated either under remote control or snow detector control.

10.3. Snow Detector Maintenance

The snow detector sensing head contains a small, self-regulating heater that will melt snow or ice into water. The sensing head relies on moisture to create a low resistance circuit path. The heater will also cause the moisture to evaporate within a short period. If the surface becomes non-conductive due to contamination by grease or oil, the sensing head will not operate. To ensure effective and dependable snow detector operation, it is important to inspect the sensing heads frequently and clean them thoroughly if necessary. Use a solution of water and mild detergent or isopropyl alcohol to clean the sensing grid. Use a clean, dry cloth to wipe the grid. Make sure there is no residue left on the surface.

10.4. Snow Detector Troubleshooting

NOTE: A newly-installed snow detector sensing head should operate 15-20 minutes to allow the internal heater to reach normal operating temperature.

10.4.1. No Heat on the Sensing Head

1. Check for voltage between terminal post 6 and 7, and between terminal post 6 and 8. It should be 18VAC (+2VAC). If not:
 - a. Check the display on the control module.
 - b. The control transformer may be defective.
 - c. There may be a bad circuit connection.
2. Remove the black and the green lead wires from the terminal posts. Check resistance between them. If resistance is greater than 10 ohms, the sensing head is defective and should be replaced.

10.4.2. Does Not Detect Moisture

1. Clean the snow detector as described in section 10.3.
2. If unit still does not detect moisture, check the wiring connections between detector head and terminal posts.
3. If unit still does not detect moisture, replace the control module with a known good control module. If still not operating properly, replace the sensing head.
NOTE: If a snow detector head becomes saturated with moisture, it can sometimes be restored to normal operation by removing it and “baking” it in a conventional oven for several hours. Do not exceed 150°F.

10.4.3. Constant Indication of Moisture Detection

1. Clean the snow detector heads as described in section 10.3.
2. Remove white lead(s) from terminal post 9. If moisture indication is still on, the control module is defective and should be replaced.

11. Specifications

VOLTAGE:	230VAC, 1PH 60HZ 50 AMP
MOTOR:	3 HP, 3450RPM, TEFC 86 Amp starting current 14.5 Amp running current
VOLTAGE:	230VAC, 1PH 60HZ 50 AMP (3PH AC DRIVE)
MOTOR:	3 HP, 3450RPM, TEFC 18 Amp starting current 18 Amp running current
VOLTAGE:	460VAC, 3PH 60HZ 15 AMP
MOTOR:	3 HP, 3450RPM, TEFC 37.5 Amp starting current 3.7 Amp running current
VOLTAGE:	575VAC, 3PH 60HZ 15 AMP
MOTOR:	3 HP, 3450RPM, TEFC 30 Amp starting current 3 Amp running current
AIRFLOW:	2500 CFM
COMBUSTION RATE:	600,000 BTU/HR 300,000 BTU/HR
FUEL:	Propane or Natural Gas
FLOW RATE:	Natural Gas: 600 CFH/300 CFH Propane: 240 CFH/120 CFH 6.6 GPH/3.3 GPH
INDICATION CONTACTS:	30VDC 1A or 125VAC 300mA
INCOMING GAS PRESSURE:	Low Pressure Regulator: 2 PSI – 10 PSI Optional High-Pressure Regulator: Max of 150 PSI
UNIT WEIGHT:	650 lbs. (295 kg)

12. Drawings

GHAB POSITIONING, HIGH	955N32903
GHAB POSITIONING, LOW	954N36903
GHAB MAIN UNIT	9558-0118
TIE DUCT ASSEMBLY 136LB E-CLIP	9528-4815
TIE DUCT ASSEMBLY 115LB E-CLIP	9528-4615
POINT / TRACK ASSEMBLY RH	9508-4000
POINT / TRACK ASSEMBLY LH	9508-4001
OUTSIDE TRACK ASSEMBLY LH	9508-4002
OUTSIDE TRACK ASSEMBLY RH	9508-4003
NOZZLE TRACK DUCT ASSEMBLY	927490
ISOLATION KIT, TIE DUCT POINT NOZZLE	9278-0021
ISOLATION KIT, TIE DUCT TRACK NOZZLE	9278-0027
GHAB FOUNDATION	9288-0302
5 HP FLAME DUCT	9528-3102
HEAVY DUTY OFFSET DUCT	9278-3402
2' INSULATED FLEX DUCT	9528-4220
TRACK DUCT, POINT LG. NOZZEL 10 FT	9278-1205
TRACK DUCT, 5' MID	9278-0227
TRACK DUCT, 10', MID	9278-1201
TRACK DUCT, 10', HEEL	9278-1202
FLEX NOZZLE KIT	9278-9500
TRACK DUCT, 30'	9278-0233
SWITCH ROD DUCT 7'	9278-0270
TRACK DUCT SUPPORT BRACKET ASSEMBLY	92774
LAYOUT, GHAB GAS LINE	R9520-0027
GHAB 3HP 230V 1PH LOW PROFILE	9548-7215
GHAB ELECT. PANEL LAYOUT 230V AC DRIVE	9558-0154
GHAB ELECT. PANEL 230V 1 PH	9558-0150
GHAB ELECT. PANEL 3 PH	9528-0224
GAS PIPING, 2 STAGE	9558-0237
AIR TEMP SENSOR, 5' MAGNETIC	9508-0404
BURNER ASSEMBLY	9528-0135
ASSY, 5HP PRESSURE SENSOR	9538-0151
PRESSURE SWITCH CALIBRATION	
FLOWCHART	

13.Limited Warranty

Railway Equipment Co., Inc. (“Railway”) warrants all of its products to be free from defects in material and workmanship when used under specified operating conditions and within specified limits. Railway’s warranty shall extend for a period of two (2) years from the date of shipment to the original purchaser.

This warranty is expressly in lieu of and excludes all other expressed or implied warranties, including but not limited to warranties of merchantability and fitness for a particular purpose.

Railway, its agents, or representatives shall in no circumstance be liable for any direct, indirect, special, penal, or consequential loss or damage of any nature resulting from the malfunction of the product.

Remedies under this warranty are expressly limited to repair or replacement of the product at the sole discretion of Railway.

Before returning any defective product to Railway, contact the factory at the address or telephone number at the bottom of this article for a Return Merchandise Authorization number and instructions as to how and where the return is to be shipped. Materials received without this authorization will be returned at the customer’s expense.

Products returned to Railway under warranty must be shipped freight prepaid, and return freight charges for repaired or replaced products, in or out of warranty, will be at customer’s expense.

Railway reserves the right to reject any warranty claim on a product that has been altered by the user or damaged in shipping due to inadequate packaging or mishandling by freight carrier.

By returning a product to Railway the owner grants permission to Railway to open and disassemble the product as required for evaluation. Railway has the sole responsibility for determining the cause and nature of failure, and Railway’s determination with regard thereto shall be final. Railway reserves the right to repair or replace any unit at its sole discretion.

A returned product that is found, upon inspection by Railway, to be operational within specification is subject to an inspection and testing fee, regardless of its warranty period.

Railway’s liability on any claim of any kind (including negligence) for any loss or damage arising out of or resulting from this agreement, or from the performance of breach thereof, of from the products or services furnished hereunder, shall in no case exceed the price of the specific product or service which gives rise to the claim. All such liability shall terminate upon the expiration of the warranty period of two (2) years, as hereinabove stated.

The furnishing of advice or other assistance without separate compensation therefore will not subject Railway to any liability, either in contract, warranty, tort (including negligence) or otherwise.

Any alteration or modification of the product, or addition on non-Railway components to the product, unless expressly permitted by Railway in its documentation, will void warranty coverage.

This warranty is non-transferable, and warranty coverage is limited to initial user only.

Installation and/or use of the product shall demonstrate acceptance of the terms of this warranty.

Each of the foregoing paragraphs in this article will apply to the full extent permitted by law. The invalidity, in whole or part, of any paragraph will not affect the remainder of such paragraph or any other paragraph.

RAILWAY EQUIPMENT CO.

525 9th Street South, Delano, Minnesota 55328 USA

Tel. (763) 972-2200 Fax (763) 972-2900

E-Mail - mail@rwy.com

PARTS LIST					DESCRIPTION
ITEM	PART NUMBER	REV	QTY	UOM	
1	9278-0233B	B	4	EA	TRACK DUCT 30"
2	9288-0302	A	1	EA	FOUNDATION ASSY, 5HP GHAB
3	9508-0364B	B	1	EA	ASSY, HI TEMP SENSOR COPPER ROD 25FT TIE DUCT MOUNT
4	9508-0415B	B	1	EA	RAIL TEMP SNSR T/C MAGNETIC
5	9508-4000B	B	1	EA	POINT/TRACK NOZZLE ASSY RH
6	9508-4001B	B	1	EA	POINT/TRACK NOZZLE ASSY LH
7	9508-4002	A	1	EA	OUTSIDE TRACK NOZZLE ASSY LH
8	9508-4003	A	1	EA	OUTSIDE TRACK NOZZLE ASSY RH
9	9528-3410A	A	1	EA	DUCT, OFFSET, 2' HD NO MIXER, 6-HOLE FLANGE
10	9528-4222	A	1	EA	FLEX DUCT 25' INS W/MIXER
11	9528-4815A	A	1	EA	TIE DUCT, 136# QUICK CHANGE, 6-HOLE FLANGE
12	9558-0118Q	Q	1	EA	MAIN GHAB, 3HP, HIGH PROFILE, LP, 230V 1PH AC DRIVE

TOP OF MOUNTING FOUNDATION SHOULD BE 4"-6" BELOW TOP OF TIES

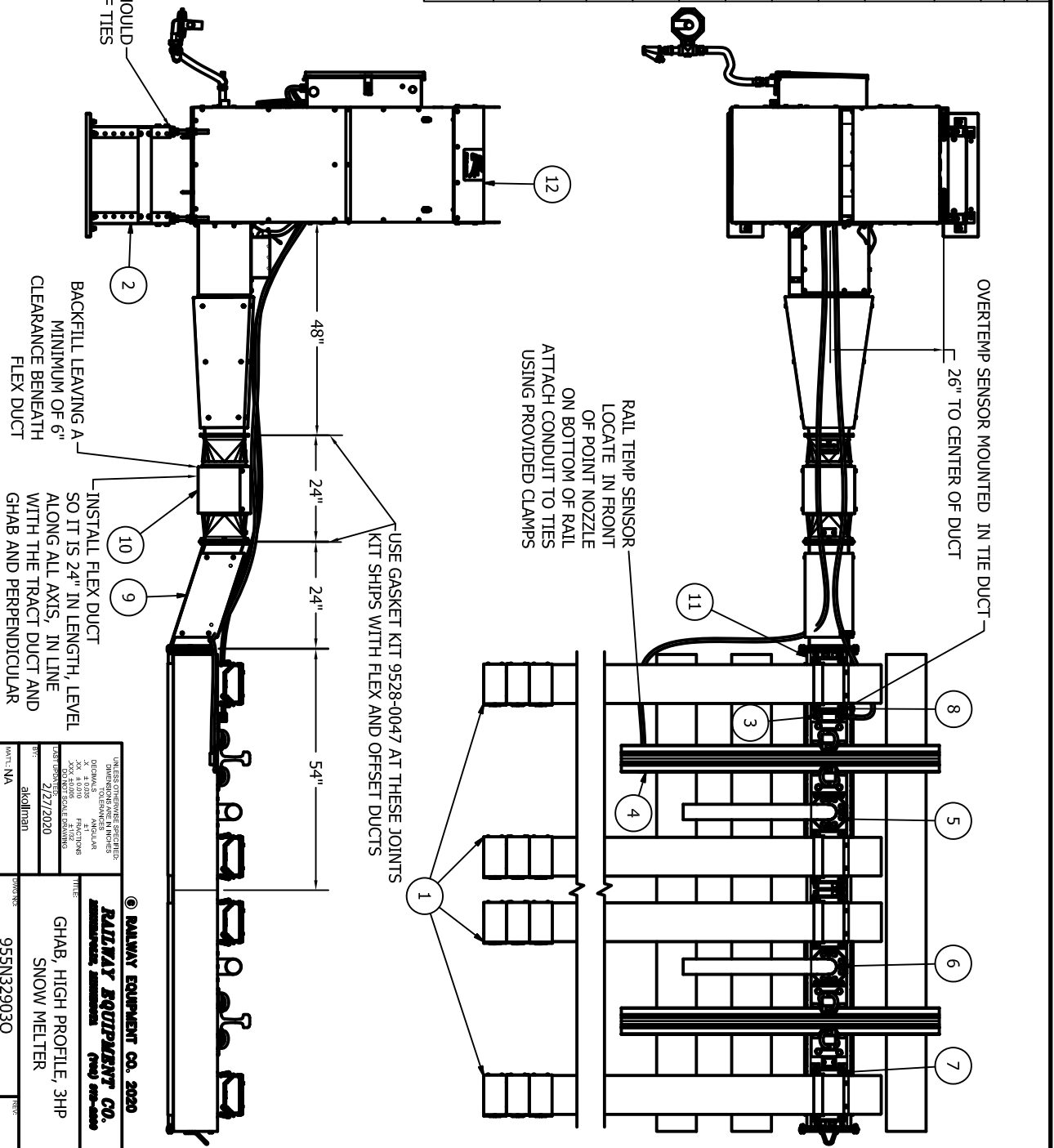

© RAILWAY EQUIPMENT CO. 2020

RAILWAY EQUIPMENT CO.
RAILWAY EQUIPMENT CO. (781) 999-4000

UNLESS OTHERWISE SPECIFIED:
DIMENSIONS ARE IN INCHES
DIMENSIONS ARE ANGULAR
XX 4.0000 FRACTIONS
XX.00000000 SCALE DIMENSIONS
DATE: 2/27/2020
BY: skollman
DRAWN BY: skollman
SCALE: 1" = 1'-0"

TITLE: GHAB, HIGH PROFILE, 3HP SNOW MELTER

PROJECT NO: 955N32903Q

SCALE: 1/23 DRAWING: B SHEET: 1 OF 1

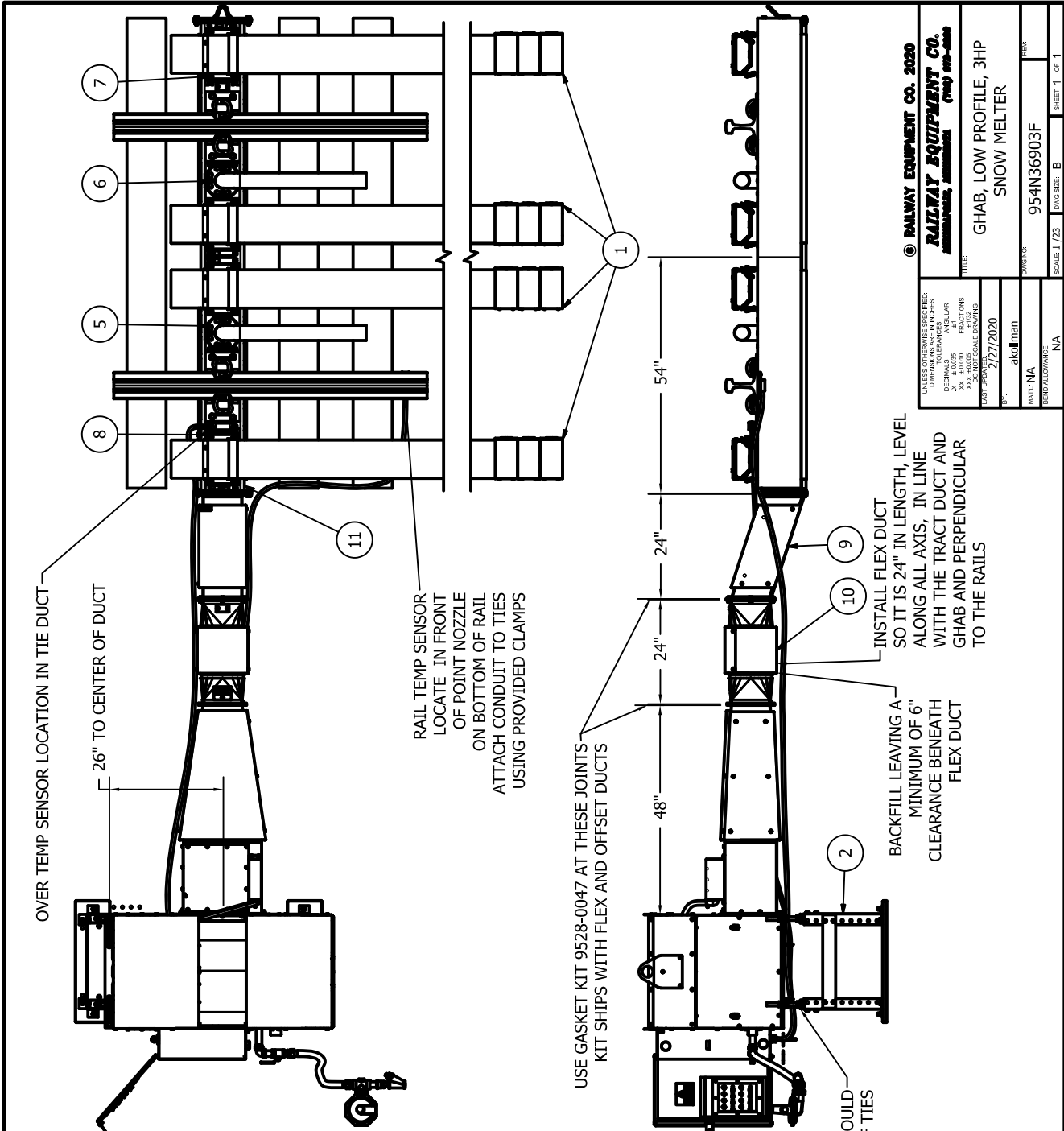

PARTS LIST

ITEM	PART NUMBER	REV	QTY	UOM	DESCRIPTION
1	9278-0233B	B	4	EA	TRACK DUCT 30'
2	9288-0302	A	1	EA	FOUNDATION ASSY, 5HP GHAB
3	9508-0365C	C	1	EA	ASSY, HI TEMP SENSOR COPPER ROD 15FT TIE DUCT MOUNT
4	9508-0415B	B	1	EA	RAIL TEMP SNRS T/C MAGNETIC
5	9508-4000B	B	1	EA	POINT/TRACK NOZZLE ASSY RH
6	9508-4001B	B	1	EA	POINT/TRACK NOZZLE ASSY LH
7	9508-4002	A	1	EA	OUTSIDE TRACK NOZZLE ASSY LH
8	9508-4003	A	1	EA	OUTSIDE TRACK NOZZLE ASSY RH
9	9528-3410A	A	1	EA	DUCT, OFFSET, 2' HD NO MIXER, 6-HOLE FLANGE
10	9528-4222	A	1	EA	FLEX DUCT 2'ST INS W/MIXER
11	9528-4815A	A	1	EA	TIE DUCT, 136# QUICK CHANGE, 6-HOLE FLANGE
12	9548-7215F	F	1	EA	MAIN GHAB, 3HP, LOW PROFILE, LP 230V 1PH WITH AC DRIVE

OVER TEMP SENSOR LOCATION IN TIE DUCT

26" TO CENTER OF DUCT

RAIL TEMP SENSOR LOCATE IN FRONT OF POINT NOZZLE

ON BOTTOM OF RAIL ATTACH CONDUIT TO TIES USING PROVIDED CLAMPS

USE GASKET KIT 9528-0047 AT THESE JOINTS KIT SHIPS WITH FLEX AND OFFSET DUCTS

48"

24"

24"

54"

1

2

3

4

5

6

7

8

9

10

11

BACKFILL LEAVING A MINIMUM OF 6" CLEARANCE BENEATH FLEX DUCT

INSTALL FLEX DUCT SO IT IS 24" IN LENGTH, LEVEL ALONG ALL AXIS, IN LINE WITH THE TRACT DUCT AND GHAB AND PERPENDICULAR TO THE RAILS

TOP OF MOUNTING FOUNDATION SHOULD BE 4"-6" BELOW TOP OF TIES

UNLESS OTHERWISE SPECIFIED:
 DIMENSIONS ARE IN INCHES
 DECIMALS TO 3 PLACES
 ANGULAR TOLEANCES
 .XX .0010 FRACTIONS
 .XX .0010 SCALE DRAWING
 DATE: 2/27/2020
 BY: akollman
 TITLE: GHAB, LOW PROFILE, 3HP SNOW MELTER
 PART NUMBER: 954N36903F
 REV: NA
 SCALE: 1/23
 SHEET: 1 OF 1

© RAILWAY EQUIPMENT CO. 2020
RAILWAY EQUIPMENT CO.
 1000 W. 10TH ST. S. #100
 MINNEAPOLIS, MN 55404
 (763) 899-3000

ITEM NUMBER	REV	UOM	QTY	DESCRIPTION
1	14169	EA	4	LATCH FOR SCREENS
2	16003	EA	.33	RTV SILICONE CLEAR 10 OZ TUBE
3	26020A	A	EA	INLET CONE 1290 90%
4	26027B	B	EA	BLOWER WHEEL ASY 3 H.P.
5	28035	EA	6	MOUNT RUBBER M/M 1/4-20
6	28045	EA	4	BOLT 3/8 X 3-1/2 HEX LAG
7	28013-0003	EA	3	BOLT 1/4-20 X 1 CARRIAGE
8	2831411112	EA	1	SCREW #10-32 X 3/4 PAN SLT
9	2831651112	EA	12	BOLT 5/16-18 X 3/4 HEX HEAD
10	2831851116	EA	12	BOLT 3/8-16 X 1 HEX CAP
11	2831861112	EA	28	BOLT 3/8-16 X 3/4 CARRIAGE
12	2832-4101	EA	2	NUT #10-32 HEX
13	2832-5101	EA	12	NUT 1/4-20 HEX
14	2832-5601	EA	7	NUT 5/16-18 CENTERLOCK
15	2832-5601	EA	12	NUT 5/16-18 CENTERLOCK
16	2832-5101	EA	14	NUT 3/8-16 HEX
17	2832-990A	EA	32	NUT 3/8-16 CENTERLOCK
18	2833-4210	EA	1	WASHER #10 SPLT LOCK
19	2833-4310	EA	2	WASHER #10 EXT. STAR
20	2833-5110	EA	14	WASHER 1/4 FLAT
21	2833-5119	EA	8	WASHER 1/4 X 1.5 FENDER
22	2833-5211	EA	14	WASHER 1/4 SPLT LOCK
23	2833-5110	EA	12	WASHER 5/16 FLAT SAE
24	2833-4000	EA	4	Rivet, BUTTON HEAD PLATED STL
25	2833-5119	EA	4	WASHER 3/8 X 1-1/2 FENDER
26	2833-5210	EA	14	WASHER 3/8 SPLT LOCK
27	29017	EA	8	BOLT #8-32 X 3/8 WASHER HEAD
28	29019	EA	12	BOLT 1/4-20 X 1.3 SHOULDER THREAD ROLLING
29	29051	EA	135	BOLT 1/4-20 X 1/2 WITH 1/2 HD
30	32002	SCF	17	INSULATION, FIBERGLASS
31	32007	EA	1	POST, 4 X 4 X 8 TREATED
32	60002	EA	1	3/8 ROMEX BRIDGEPORT# 650-D02
33	60076	EA	1	CONDUIT, FLEX CLAMPS 3/4 IN
34	60169	EA	12	TY-RAP 0.30 X 8
35	60189A	A	FT	8 GASKET, 0.25 X 0.75 ADHESIVE BACK
36	60195	EA	5	CABLE TIE .4IN 0.10 WIDTH
37	6093-0100	EA	5	CABLE TIE .4IN 0.10 WIDTH
38	6093-0102	EA	12	TY-RAP
39	61032	EA	1	NIPPLE 1 X 3 IN SCH 40 BLACK
40	61047	EA	1	NIPPLE 1 X 3 IN SCH 40 BLACK
41	61058	EA	1	ELBOW, 1IN SCH 40 BLACK
42	61070	EA	1	U-BOLT, MRO BOLT #405
43	8004-0955E	E	EA	1 NAMEPLATE 954955 GHAB
44	92919A	A	EA	4 WASHER, 1/4 EXT. STAR
45	950132B	B	EA	1 DUCT, FLAME DUCT, 5HP W SENSOR
46	95056C	C	EA	1 BRACKET, GAS SUPORT INSIDE
47	95058C	C	EA	1 COVER PLATE, GAS LINE 5 & 3HP
48	95059A	A	EA	1 COVER, MUFFLER GHAB
49	9508-0038A	A	EA	1 ASSY, GAS SENSOR EXT CABLE
50	9508-0385C	C	EA	1 ASSY, HI TEMP SENSOR OR 15 FT THE DUCT MOUNT
51	9508-0404A	A	EA	1 AIR TEMPERATURE SENSOR 4" MAGNETIC
52	9508-0415B	B	EA	1 RAIL, TEMP SNSR TIC MAGNETIC
53	9508-0433A	A	EA	1 ASSY, WIRED IGNITION XFIMER
54	9508-0498B	B	EA	1 ASSY, FLAME WIRE
55	95202A	A	EA	1 PLATE, MOTOR BASE, 184T GHAB
56	95202B	B	EA	1 COVER, MOTOR
57	952127C	C	EA	2 STUD PLATE
58	952134C	C	EA	1 INTAKE BODY, 5HP
59	952135B	B	EA	1 MOTOR MOUNTING PLATE, HAB
60	952136A	A	EA	4 LIFTING PLATE
61	952137A	A	EA	1 DEFLECTOR, INTAKE 3.5HP GHAB
62	952138A	A	EA	1 COVER, LOWER INTAKE, 3.5HP
63	952139A	A	EA	1 COVER, UPPER INTAKE, 5HP

ITEM NUMBER	REV	UOM	QTY	DESCRIPTION
64	95227E	E	EA	1 BASE GHAB, 3.5HP
65	952688A	A	EA	1 BASE GHAB MOTOR
66	9528-0027E	E	EA	1 ASSY, GAS LINE ACCESSORIES 3.5HP
67	9528-0074D	D	EA	1 GASKET KIT, 9X9 5HP DUCTWORK
68	9528-0135C	C	EA	1 BURNER, 12IN STAINLESS STEEL
69	952810B	B	EA	1 INSUL COVER, REDUCER WRAP
70	952811A	A	EA	1 INSUL BASE, REDUCER WRAP
71	952813A	A	EA	1 COVER, ACCESS 952 BURNER
72	95309C	C	EA	1 INTAKE TOP, HAB, 3.5HP
73	953254A	A	EA	2 INTAKE SCREEN, FLIP DOWN 1"
74	953255A	A	EA	2 DRIP RAIL, HAB WITH LATCHES
75	95347B	B	EA	1 ENCLOSURE, HAB WELDMENT
76	9538-0048A	A	EA	1 ASSEMBLY, IGNITION WIRE
77	9538-0151A	A	EA	1 ASSY, 5HP PRESSURE SWITCH AND SENSOR BLOWER ASSEMBLY
78	9558-0155C	C	EA	1 ASSY GHAB CONTROL PANEL, 3HP, 1PH, 240V
79	9558-0237C	C	EA	1 GHAB GAS PIPING W PRESSURE SENSOR
80	960632B	B	EA	1 BLOWER AIR CUT FLANGE 3.5HP
81	96346A	A	EA	1 MOTOR MOUNTING PLATE, HAB
82	963900B	B	EA	1 BLOWER OUTLET FLANGE 5HP
83	963903B	B	EA	1 BLOWER SHROUD 3.5HP
84	9658-0028B	B	EA	1 ASSY, WIRED MOTOR, 3HP/230V/PH
85	9609-1051	A	EA	1 RRAMAC LIFETIME ASSET REGISTRATION FEE
86	R8039-0816A	A	EA	1 LABEL, FAN ROTATION
87	R8039-0830A	A	EA	1 LABEL, GHAB WARNINGS
88	R8039-0951A	A	EA	1 LABEL, GAS CONNECTION BULKHEAD
89	R8039-0955B	B	EA	1 LABEL, ID PLATE AGACSA
90	954955-0100J	J	EA	2 LABEL, HAB ENCLOSURE
91	R960031	EA	2	LABEL, HAB ENCLOSURE
92	R99001A	A	EA	1 LABEL, CAUTION LABEL INSIDE GHAB ENCLOSURES

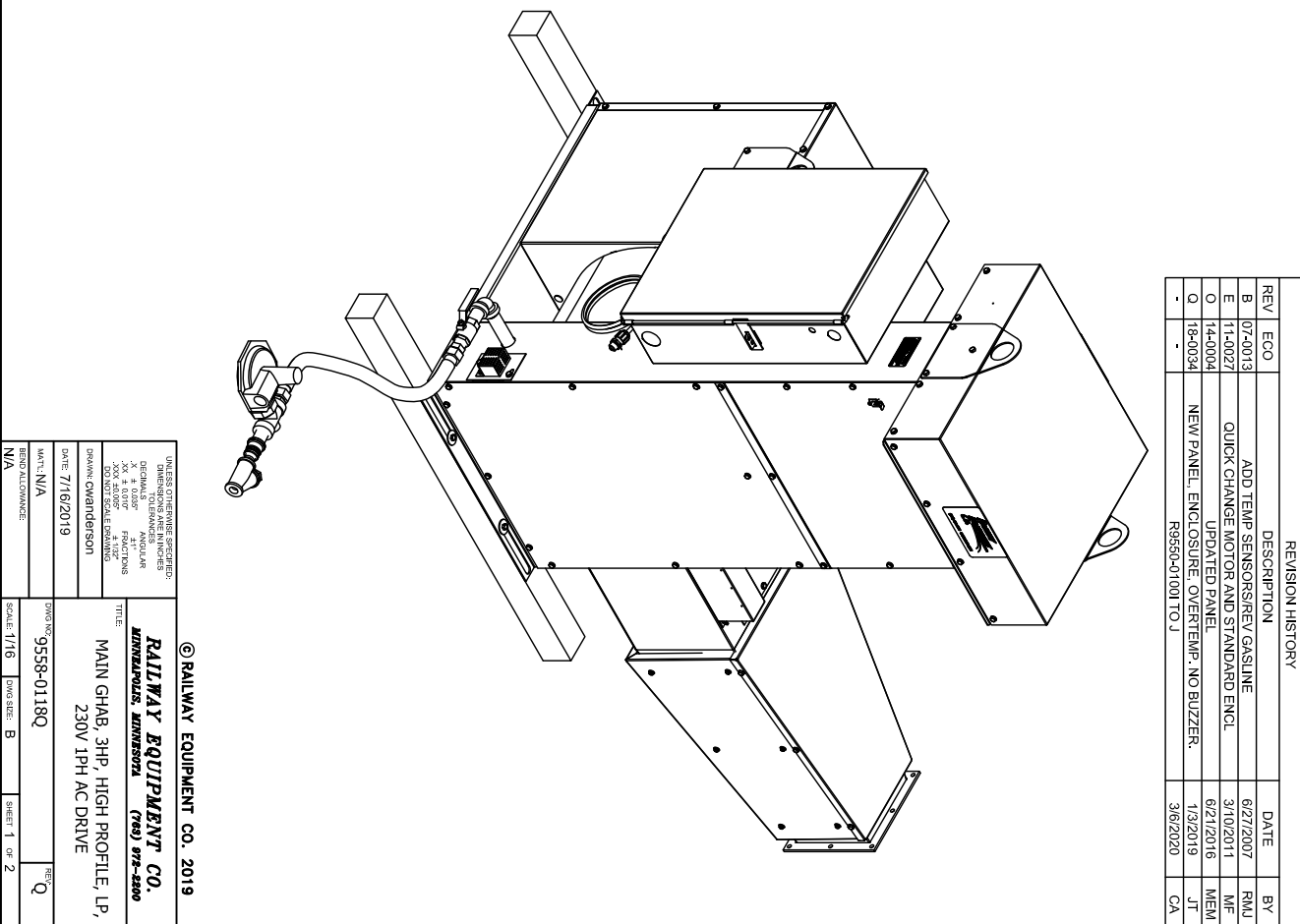

REV	ECO	DESCRIPTION	DATE	BY
07-0013	B	ADD TEMP SENSOR/REV GASLINE	6/27/2007	RMJ
11-0027	E	QUICK CHANGE MOTOR AND STANDARD ENCL	3/10/2011	MF
14-0004	O	UPDATED PANEL	6/21/2016	MEM
18-0034	Q	NEW PANEL, ENCLOSURE OVERTEMP, NO BUZZER.	1/3/2019	JT
-	-	R9550-0100 TO J	3/6/2020	CA

UNLESS OTHERWISE SPECIFIED:
 DIMENSIONS ARE IN INCHES
 DIMENSIONS IN ANGULAR
 X.X, 4.0 OR 9
 FRACTIONS
 DECIMALS ARE TO BE ROUNDED TO THE NEAREST
 100 TH OF AN INCH
 DRAWING OWNERSHIP:
 DATE: 7/16/2019
 WRT: N/A
 TENG: ALLOWANCE
 N/A

© RAILWAY EQUIPMENT CO. 2019
RAILWAY EQUIPMENT CO.
 MINNETONKA, MINNESOTA (763) 876-2500

TITLE:
 MAIN GHAB, 3HP, HIGH PROFILE, LP,
 230V 1PH AC DRIVE

DWG NO: 9558-0118Q
 WRT: N/A
 TENG: ALLOWANCE
 N/A

SCALE: 1/16 DIMS: B SHEET 1 OF 2

UNLESS OTHERWISE SPECIFIED:
 DIMENSIONS ARE IN INCHES
 DECIMALS TO NEAREST HUNDRED
 ANGULAR DIMENSIONS TO NEAREST 5 MINUTES
 FRACTIONS TO NEAREST 1/32
 TOLERANCES UNLESS OTHERWISE SPECIFIED:
 .XX ± 0.010"
 .XXX ± 0.005"
 .XXX ± 0.002"
 .XXX ± 0.001"
 .XXX ± 0.0005"
 .XXX ± 0.0002"

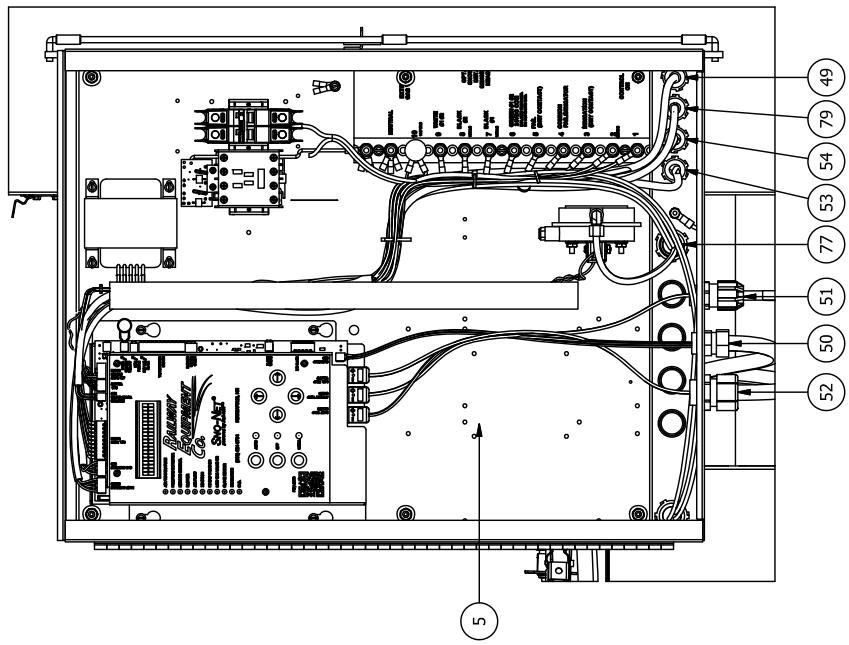
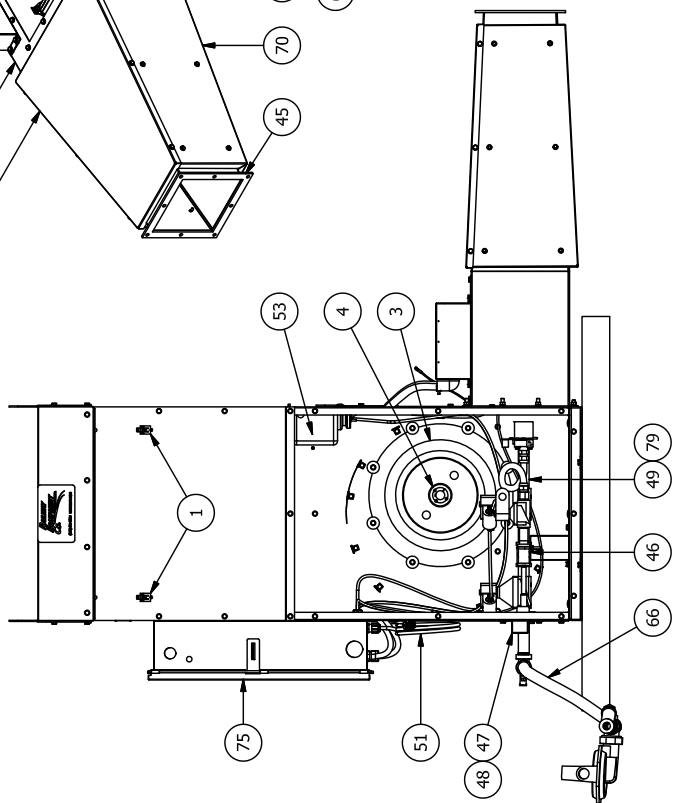
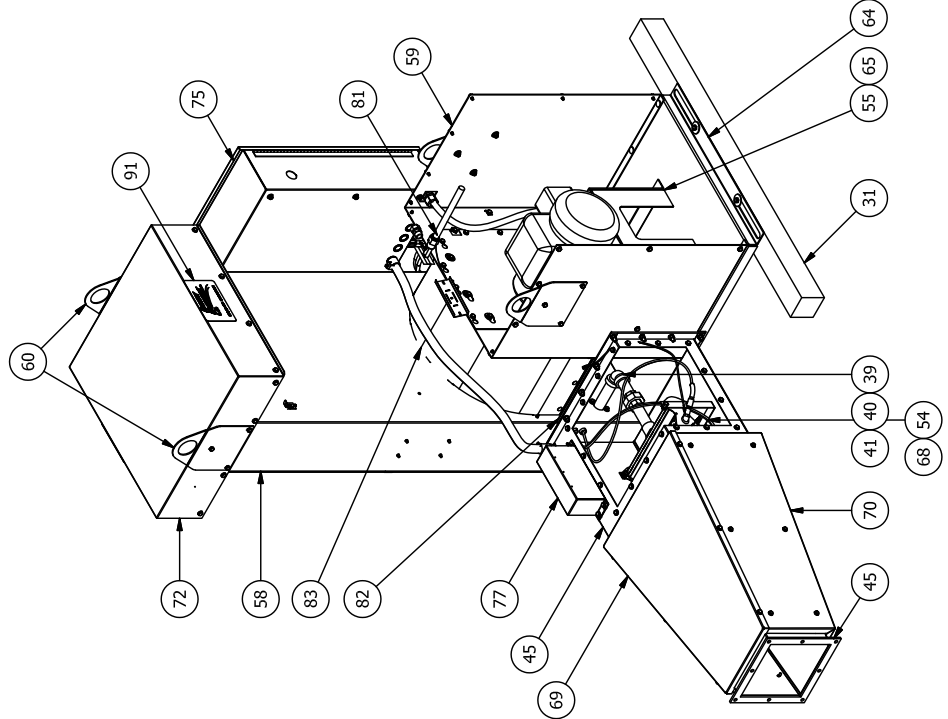

© RAILWAY EQUIPMENT CO. 2019
RAILWAY EQUIPMENT CO.
 MINNEAPOLIS, MINNESOTA (763) 972-2200
 TITLE: MAIN GHAB, 3HP, HIGH PROFILE, LP,
 230V 1PH AC DRIVE
 DWG NO: 9558-0118Q
 DATE: 7/16/2019
 DESIGNED BY: N/A
 CHECKED BY: N/A
 SCALE: 1:1
 SHEET: 2 OF 2

ITEM	PART NUMBER	REV	QTY	UOM	DESCRIPTION	ITEM	PART NUMBER	REV	QTY	UOM	DESCRIPTION
1	12425	-	1080	IN	TAPE ROLL 2 INCH WIDE HEAVY	14	927237	A	2	EA	COVER PLATE, TEMP SENSOR
2	14150	-	1	EA	BAG, BURLAP 10" X 14" 100Z	15	927248	A	4	EA	RAIL CLIP, TIE DUCT
3	14151	-	1	EA	WIRE BURLAP BAG CLOSING TIES 6"	16	927355	B	2	EA	TIE PLATE 136# E-CLIP-PAD TYPE
4	28121	-	8	EA	BOLT, 3/4-10 X 1-1/2 HEX SS	17	927366	A	4	EA	E-CLIP INSULATOR
5	2831851114	-	4	EA	BOLT, 3/8-16 X 1 HEX HEAD, SS	18	927367	B	2	EA	PAD FOR E-CLIP RUBBER 136# TIE
6	2831951121	-	12	EA	BOLT, 1/2-13 X 1.25 HEX SS	19	927602	A	2	EA	COVER, POINT/TRACK NOZZLE
7	2831951123	-	4	EA	BOLT, 1/2-13 X 1.75 HEX SS	20	927603	A	2	EA	COVER, OUTSIDE TRACK NOZZLE
8	2831951124	-	12	EA	BOLT, 1/2-13 X 1-1/2 HEX HEAD	21	952572A	A	2	EA	COVER PLATE WITH LIFTING LUG 6-HOLE PATTERN
9	2832-9901	-	12	EA	NUT, 1/2-13 CENTERLOCK GRADE 5 ZINC	22	952573B	B	1	EA	ASSY, TIE DUCT QUICK CHANGE, 6-HOLE FLANGE
10	2833-8210	-	4	EA	WASHER, 3/8 SPLIT LOCK	23	952574A	A	2	EA	GASKET, TIE DUCT 6-HOLE PATTERN
11	2833-9009	-	8	EA	WASHER, 3/4 SPLIT LOCK	24	R8039-0904D	D	2	EA	CAUTION LABEL, TIE DUCT 136#
12	2833-9020	-	16	EA	WASHER, M12 SPLIT-LOCK	25	R8039-0914D	D	1	EA	TAG, ACCESS PARTS FOR TIE DUCT136#
13	60169	-	2	EA	TY-RAP, 0.30 X 8						

PARTS LIST

PARTS LIST

REVISION HISTORY				
REV	ECO #	DESCRIPTION	DATE	BY
A	17-0017	NEW PART	1/22/2018	JT

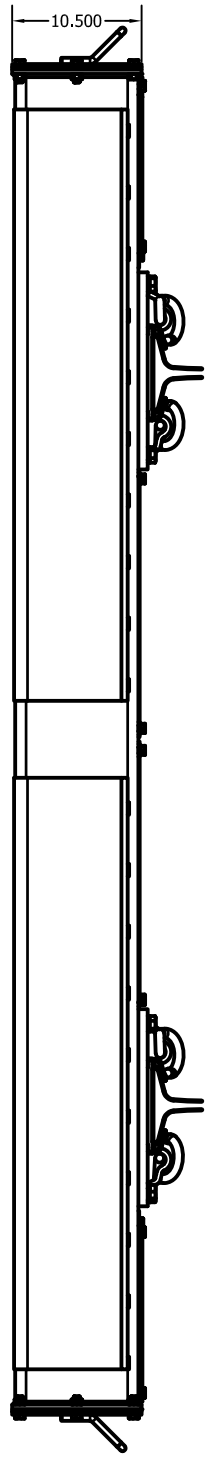
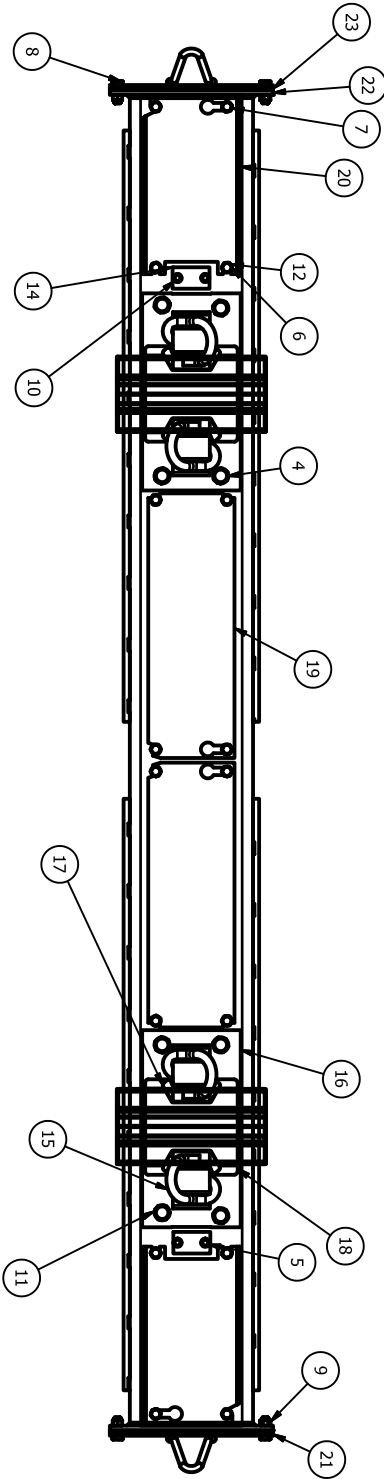

RAILWAY EQUIPMENT CO. 2017

RAILWAY EQUIPMENT CO.
Manufacturing Innovation (TM) 800-800-8000

UNLESS OTHERWISE SPECIFIED:
 DIMENSIONS ARE IN INCHES
 DECIMALS ANGULAR
 .XX 4 010" FRACTIONS
 .XXX NOT SCALE DRAWING

DESIGNER: TBERTOLDI
 DATE: 1/24/2019
 UOM: N/A
 PARTIAL QUANTITY: N/A

TITLE: TIE DUCT, 136# QUICK CHANGE, 6-HOLE FLANGE

DWG NO: 9528-4815A
 PARTIAL QUANTITY: N/A
 SCALE: 1/10
 DIM STYLE: B
 SHEET 1 OF 1

REV	ECO #	DESCRIPTION	DATE	BY
A	17-0017	NEW PART	9/13/2018	TB

PARTS LIST					
ITEM	PART NUMBER	REV	QTY	UOM	DESCRIPTION
1	12425	-	1080	IN	TAPE ROLL 2 INCH WIDE HEAVY
2	14150	-	1	EA	BAG, BURLAP 10" X 14" 100Z
3	14151	-	1	EA	WIRE BURLAP BAG CLOSING TIES 6"
4	28121	-	8	EA	BOLT, 3/4-10 X 1-1/2 HEX SS
5	2831851114	-	4	EA	BOLT, 3/8-16 X 1 HEX HEAD, SS
6	2831951121	-	12	EA	BOLT, 1/2-13 X 1.25 HEX SS
7	2831951123	-	4	EA	BOLT, 1/2-13 X 1.75 HEX SS
8	2831951124	-	12	EA	BOLT, 1/2-13 X 1-1/2 HEX HEAD
9	2832-9901	-	12	EA	NUT, 1/2-13 CENTERLOCK GRADE 5 ZINC
10	2833-8210	-	4	EA	WASHER, 3/8 SPLIT LOCK
11	2833-9009	-	8	EA	WASHER, 3/4 SPLIT LOCK
12	2833-9020	-	16	EA	WASHER, M12 SPLIT-LOCK
13	60169	-	2	EA	TY-RAP, 0.30 X 8

PARTS LIST					
ITEM	PART NUMBER	REV	QTY	UOM	DESCRIPTION
14	927237	A	2	EA	COVER PLATE, TEMP SENSOR
15	927248	A	4	EA	RAIL CLIP, TIE DUCT
16	927356	B	2	EA	TIE PLATE 115# E-CLIP PAD TYPE
17	927366	A	4	EA	E-CLIP INSULATOR
18	9273688	B	2	EA	PAD FOR E-CLIP RUBBER 115# TIE
19	927602	A	2	EA	COVER, POINT/TRACK NOZZLE
20	927603	A	2	EA	COVER, OUTSIDE TRACK NOZZLE
21	952572A	A	2	EA	COVER PLATE WITH LIFTING LUG 6-HOLE PATTERN
22	952573B	B	1	EA	ASSY, TIE DUCT QUICK CHANGE, 6-HOLE FLANGE
23	952574A	A	2	EA	GASKET, TIE DUCT 6-HOLE PATTERN
24	R8039-0905D	D	2	EA	CAUTION LABEL, TIE DUCT 115#
25	R8039-0915D	D	1	EA	TAG, ACCESS PARTS FOR TIE DUCT 115#

REVISION HISTORY				
REV	ECO #	DESCRIPTION	DATE	BY
A	17-0017	NEW PART	9/13/2018	TB

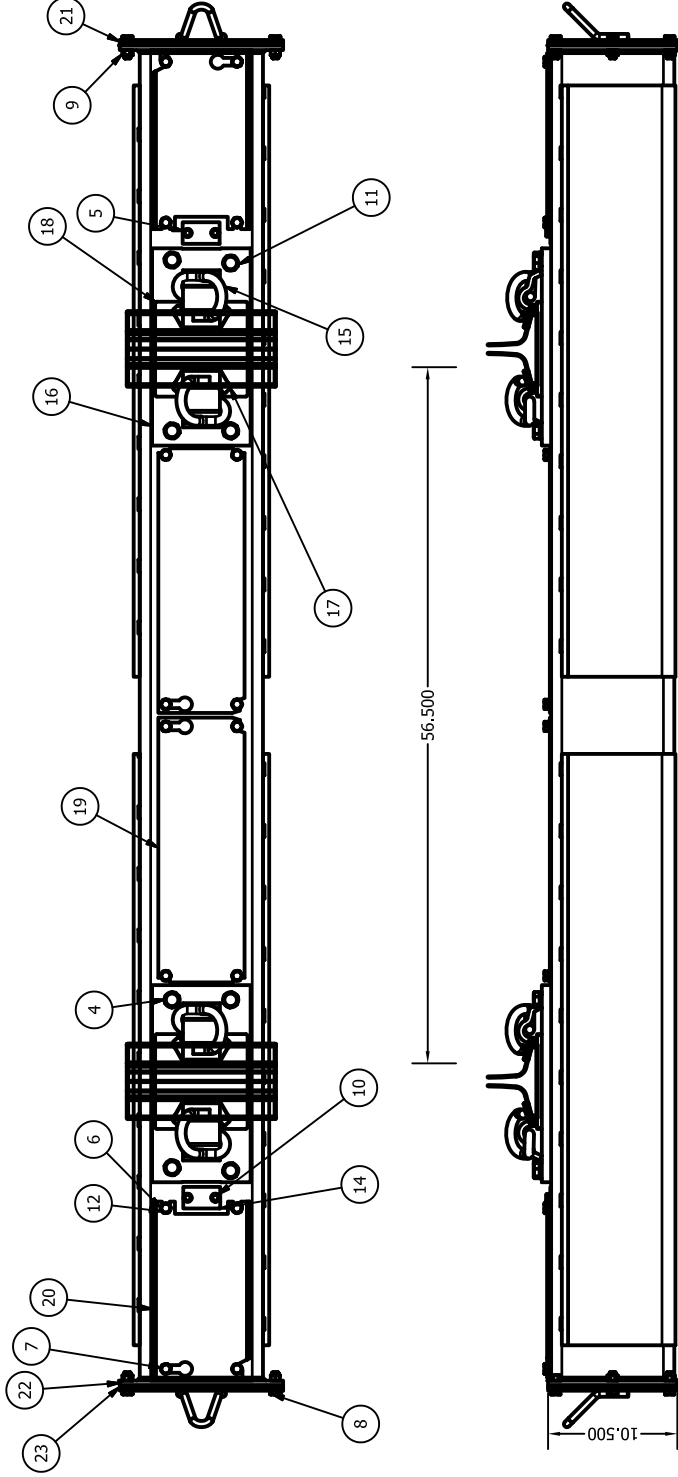

UNLESS OTHERWISE SPECIFIED:
 DIMENSIONS ARE IN INCHES
 DECIMALS - ANGULAR
 .XX, .X, .010" FRACTIONS
 .XX, 4, 010" FRACTIONS
 .00 NOT SCALE DRAWING

DRAWN: TBERTOLDI
 DATE: 1/24/2019
 TITLE: TIE DUCT, 115# QUICK CHANGE, 6-HOLE FLANGE

DWG NO: 9528-4615A
 REVISION: A
 SCALE: 1/10
 SHEET: B
 SHEET 1 OF 1

© RAILWAY EQUIPMENT CO. 2018
RAILWAY EQUIPMENT CO.
 1000 W. 10TH AVE., DENVER, CO 80202
 (303) 499-8889

PARTS LIST					
ITEM	PART NUMBER	REV	QTY	UOM	DESCRIPTION
1	28106	-	8	EA	SPACER, .38X.625X.375 ROUND
2	2832-8101	-	8	EA	NUT, 3/8-16 HEX
3	2833-8110	-	8	EA	WASHER, 3/8 FLAT
4	2833-8210	-	8	EA	WASHER, 3/8 SPLIT LOCK
5	2833-9014	-	4	EA	WASHER, 5/8 FLAT SAE
6	2833-9015	B	8	EA	WASHER, ISOLATING NOZZLE
7	60195	-	2	FT	GASKET, .25 X 1.0 ADHESIVE BK
8	92742	-	2	EA	SPRING, TRACK DUCT SUPPORT
9	92743	B	2	EA	CLIP, HOLDDOWN SPRING
10	92745	A	1	EA	HOLDDOWN STRAP, T. DUCT
11	927488	A	1	EA	NOZZLE, TRACK DUCT, NO DAMPER
12	92757	D	1	EA	GASKET, ISO, PT NOZZLE RED
13	92759	B	1	EA	GASKET, ISO, TR NOZZLE RED
14	927600	B	1	EA	POINT/TD NOZZLE MOUNT PLATE RH
15	927701	A	1	EA	SCREEN, POINT NOZZLE
16	927702	A	1	EA	SCREEN TRACK DUCT NOZZLE LARGE
17	936171A	A	1	EA	POINT NOZZLE, ROUND GALV
18	R9508-4000B	B	1	EA	LABEL, QUICK NOZZLE ASSY RH

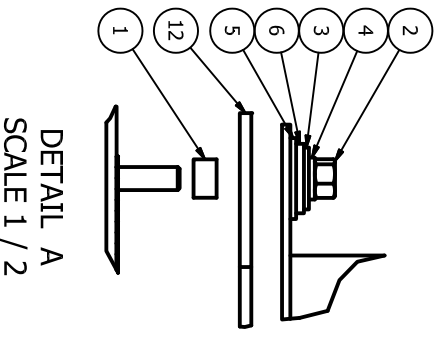

DETAIL A
SCALE 1 / 2

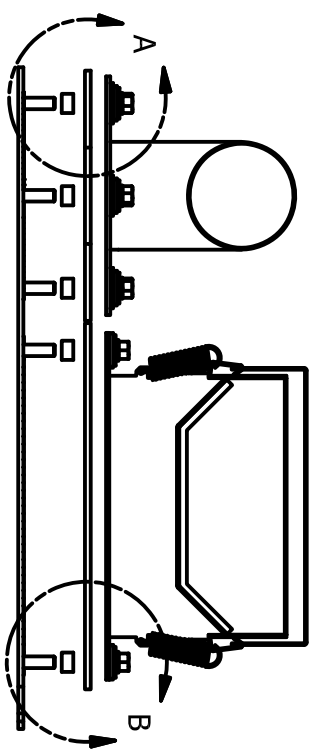

DETAIL B
SCALE 1 / 2

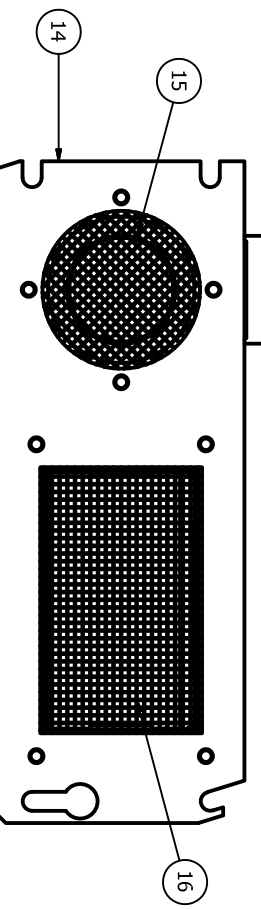

REVISION HISTORY				
REV	ECO #	DESCRIPTION	DATE	BY
A	06-0024	NEW PART	10/19/2006	WS
B	18-0011	ROUND POINT NOZZLE	10/23/2018	TB

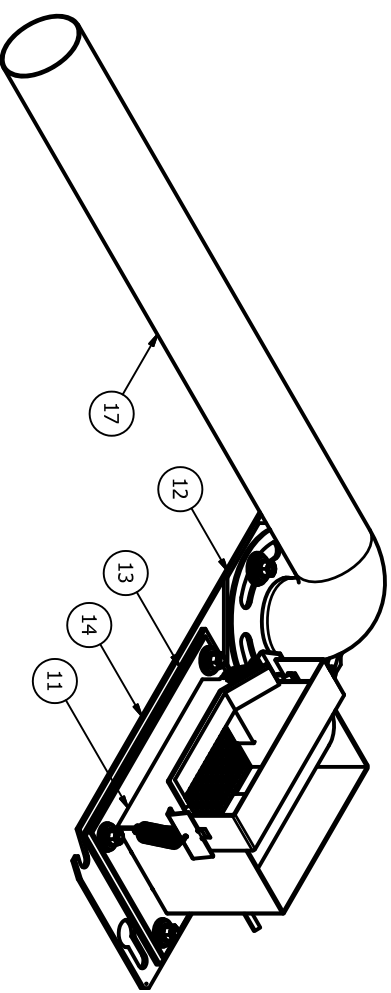

UNLESS OTHERWISE SPECIFIED:
DIMENSIONS ARE IN INCHES
DECIMALS ANGULAR
.XX & .010" FRACTIONS
X.XX & .010" SCALE DRAWINGS
X.XX & .010" SCALE DRAWINGS

DATE: 10/23/2018
BY: TBERTOLDI

© RAILWAY EQUIPMENT CO. 2018
RAILWAY EQUIPMENT CO.
9508-4000B

POINT/TRACK NOZZLE ASSY RH

SCALE: 1/5 DRAWING NO: 9508-4000B SHEET 1 OF 1

REVISION HISTORY				
REV	ECO #	DESCRIPTION	DATE	BY
A	06-0024	NEW PART	10/19/2006	WS
B	18-0011	ROUND POINT NOZZLE	10/23/2018	TB

PARTS LIST					
ITEM	PART NUMBER	REV	QTY	UOM	DESCRIPTION
1	28106	-	8	EA	SPACER, .38X.625X.375 ROUND
2	2832-8101	-	8	EA	NUT, 3/8-16 HEX
3	2833-8110	-	8	EA	WASHER, 3/8 FLAT
4	2833-8210	-	8	EA	WASHER, 3/8 SPLIT LOCK
5	2833-9014	-	4	EA	WASHER, 5/8 FLAT SAE
6	2833-9015	B	8	EA	WASHER, ISOLATING NOZZLE
7	60195	-	2	FT	GASKET, .25 X 1.0 ADHESIVE BK
8	92742	-	2	EA	SPRING, TRACK DUCT SUPPORT
9	92743	B	2	EA	CLIP, HOLDDOWN SPRING
10	92745	A	1	EA	HOLDDOWN STRAP, T. DUCT
11	927488	A	1	EA	NOZZLE, TRACK DUCT, NO DAMPER
12	92757	D	1	EA	GASKET, ISO, PT NOZZLE RED
13	92759	B	1	EA	GASKET, ISO, TR NOZZLE RED
14	927606	B	1	EA	POINT/TD NOZZLE MOUNT PLATE LH
15	927701	A	1	EA	SCREEN, POINT NOZZLE
16	927702	A	1	EA	SCREEN TRACK DUCT NOZZLE LARGE
17	936171A	A	1	EA	POINT NOZZLE, ROUND GALV
18	R9508-4001B	B	1	EA	LABEL, QUICK NOZZLE ASSY LH

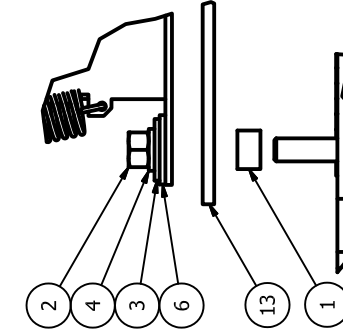
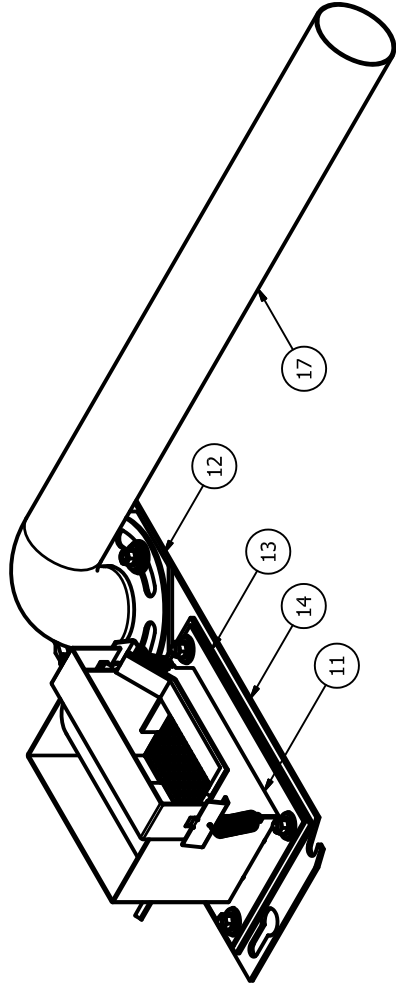

DETAIL A
SCALE 1 / 2

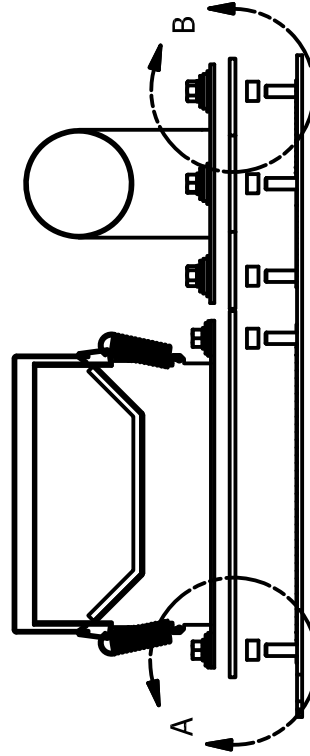

DETAIL B
SCALE 1 / 2

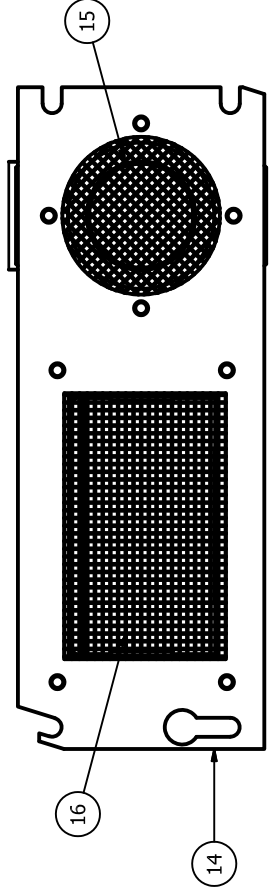

UNLESS OTHERWISE SPECIFIED:
DIMENSIONS IN INCHES
DIMENSIONS IN PARENTHESIS ARE ANGULAR
DIMENSIONS IN PARENTHESIS ARE FRACTIONS
.XX ±.01" .XX ±.01" .XX ±.01" .XX ±.01"
TOLERANCE SCALE TRAINING

© RAILWAY EQUIPMENT CO. 2018
RAILWAY EQUIPMENT CO.
RAILWAY EQUIPMENT CO.
RAILWAY EQUIPMENT CO.

TITLE
POINT/TRACK NOZZLE ASSY LH

DATE
10/23/2018

BY
TBERSTOLDI

MATERIAL
N/A

REVISIONS
N/A

SCALE
1/5

FIG. SIZE
B

SHEET 1 OF 1

9508-4001B

B

1

PARTS LIST					
ITEM	PART NUMBER	REV	QTY	UOM	DESCRIPTION
1	28106	-	4	EA	SPACER, .38X.625X.375 ROUND
2	2832-8101	-	4	EA	NUT, 3/8-16 HEX
3	2833-8110	-	4	EA	WASHER, 3/8 FLAT
4	2833-8210	-	4	EA	WASHER, 3/8 SPLIT LOCK
5	2833-9015	B	4	EA	WASHER, ISOLATING NOZZLE
6	60195	-	2	FT	GASKET, .25 X 1.0 ADHESIVE BK
7	92742	B	2	EA	SPRING, TRACK DUCT SUPPORT
8	92743	B	2	EA	CLIP, HOLDDOWN SPRING
9	92745	A	1	EA	HOLDDOWN STRAP, T. DUCT
10	927488	A	1	EA	NOZZLE, TRACK DUCT, NO DAMPER
11	92759	B	1	EA	GASKET, ISO, TR NOZZLE RED
12	927604	B	1	EA	TRACK DUCT NOZZLE MOUNT PLATE
13	927702	A	1	EA	SCREEN TRACK DUCT NOZZLE LARGE
14	R9508-4002	A	1	EA	LABEL, QUICK NOZZLE ASSY LH

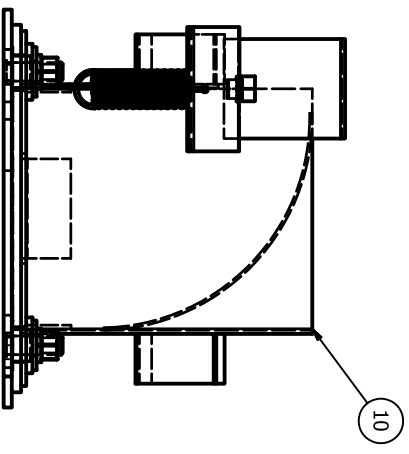
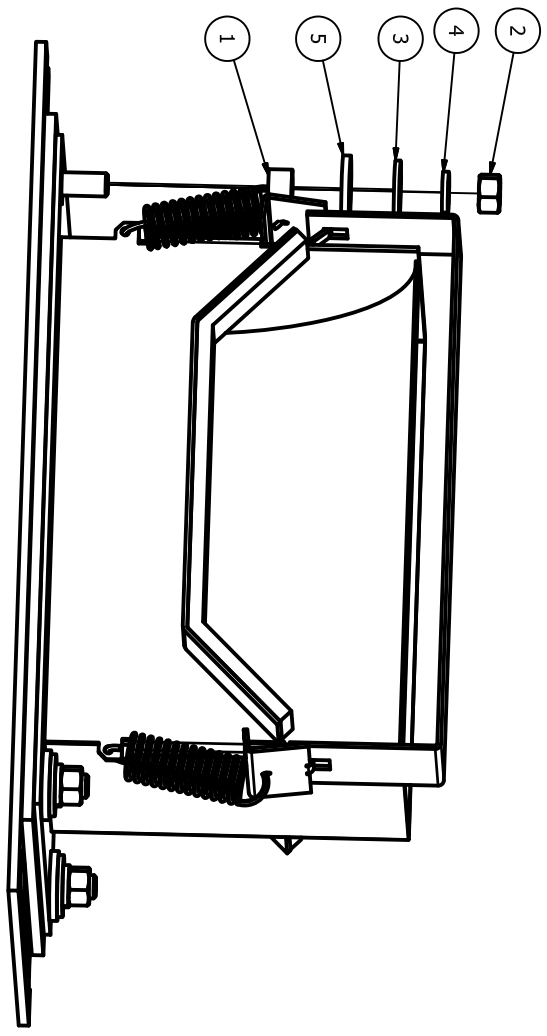
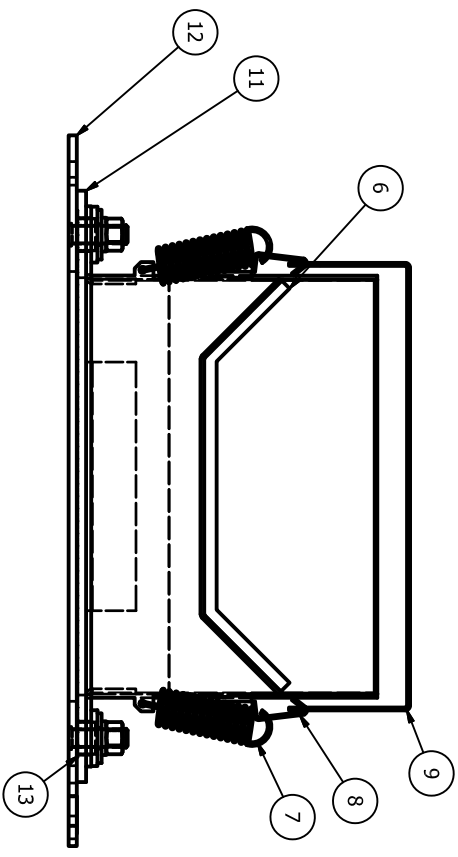
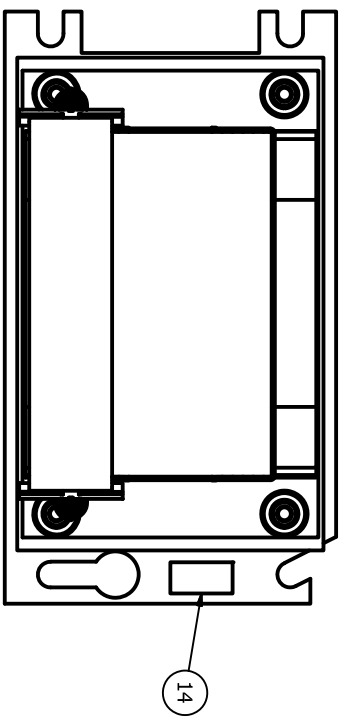

REVISION HISTORY				
REV	ECO #	DESCRIPTION	DATE	BY
A	06-0024	NEW PART	10/24/2006	WS

UNLESS OTHERWISE SPECIFIED:
 DIMENSIONS ARE IN INCHES
 DECIMALS ANGULAR
 XX.XX 16:100
 FRACTIONS
 XX 3/16 16:100
 3/16 16:100
 3/16 16:100
 3/16 16:100

DATE PREPARED: 1/17/2020
 DRAWN BY: gwandersen
 CHECKED BY: NA
 SCALE: 1/25
 TITLE: OUTSIDE TRACK NOZZLE ASSY LH
 PART NO: 9508-4002
 SHEET 1 OF 1

RAILWAY EQUIPMENT CO. 2020
RAILWAY EQUIPMENT CO.
RAILWAY EQUIPMENT CO.
RAILWAY EQUIPMENT CO.
RAILWAY EQUIPMENT CO.

REVISION HISTORY			
REV	ECO #	DESCRIPTION	DATE
A	06-0024	NEW PART	10/24/2006

ITEM	PART NUMBER	REV	QTY	UOM	DESCRIPTION
1	28106	-	4	EA	SPACER, .38X.625X.375 ROUND
2	2832-8101	-	4	EA	NUT, 3/8-16 HEX
3	2833-8110	-	4	EA	WASHER, 3/8 FLAT
4	2833-8210	-	4	EA	WASHER, 3/8 SPLIT LOCK
5	2833-9015	B	4	EA	WASHER, ISOLATING NOZZLE
6	60195	-	2	FT	GASKET, .25 X 1.0 ADHESIVE BK
7	92742	B	2	EA	SPRING, TRACK DUCT SUPPORT
8	92743	B	2	EA	CLIP, HOLDDOWN SPRING
9	92745	A	1	EA	HOLDDOWN STRAP, T. DUCT
10	927488	A	1	EA	NOZZLE, TRACK DUCT, NO DAMPER
11	92759	B	1	EA	GASKET, ISO, TR NOZZLE RED
12	927604	B	1	EA	TRACK DUCT NOZZLE MOUNT PLATE
13	927702	A	1	EA	SCREEN TRACK DUCT NOZZLE LARGE
14	R9508-4003	A	1	EA	LABEL, QUICK NOZZLE ASSY RH

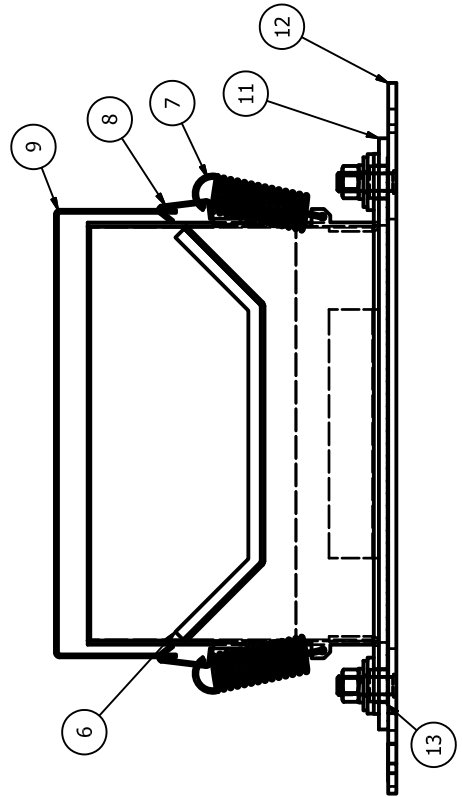
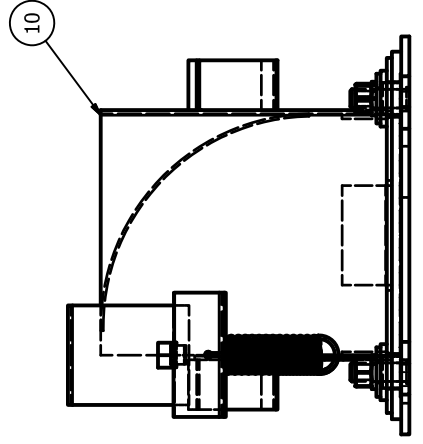
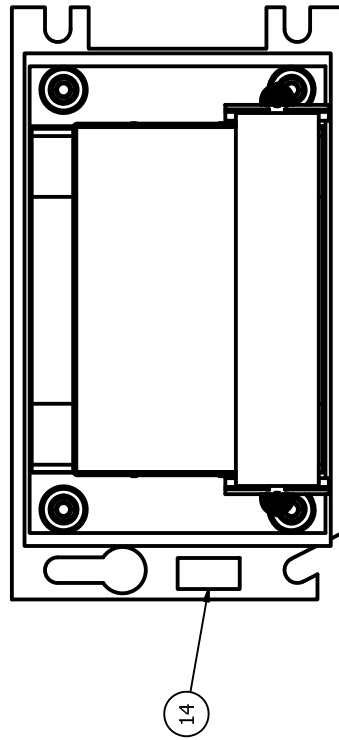
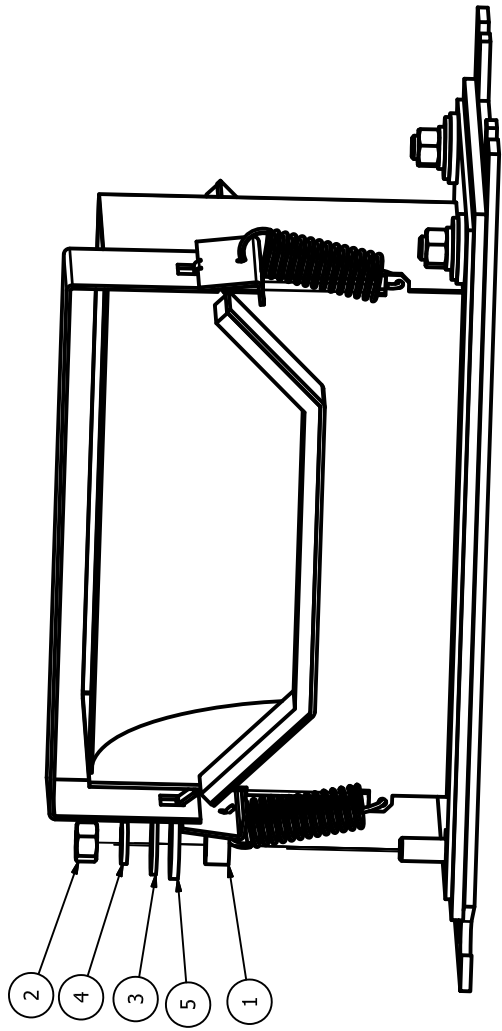

© RAILWAY EQUIPMENT CO. 2020
RAILWAY EQUIPMENT CO.
 MANUFACTURING, MINNESOTA

UNLESS OTHERWISE SPECIFIED:
 DIMENSIONS IN INCHES
 DECIMALS TO THIRDS
 FRACTIONS TO SIXTEENTHS
 .XX = 0.0005
 .XXX = 0.0001 SCALE DRAWING
 DATE UPDATED: 1/17/2020
 BY: cvanderson

TITLE: OUTSIDE TRACK NOZZLE ASSY
 LH
 DWG NO: 9508-4003
 SCALE: 1/2.5
 DWS SIZE: B
 SHEET: 1 OF 1
 PART: NA
 REV: A

ITEM	PART NUMBER	QTY	DESCRIPTION
1	927488	A	EA 1 NOZZLE, TRACK DUCT NO DAMPER
2	92745	A	EA 1 HOLDOWN STRAP, T. DUCT
5	92742	-	EA 2 SPRING, TRACK DUCT SUPPORT
4	92743	B	EA 2 CLIP, HOLDOWN SPRING
7	60195	-	FT 1.67 GASKET, .25 X 1.0 ADHESIVE BK
8	R927490A	EA	EA 1 LABEL, ID

Parts List

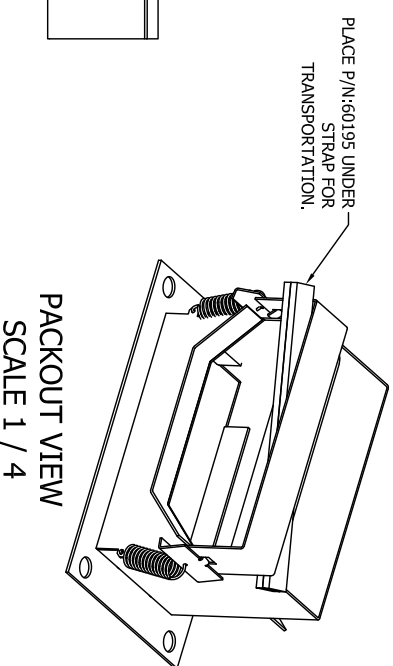
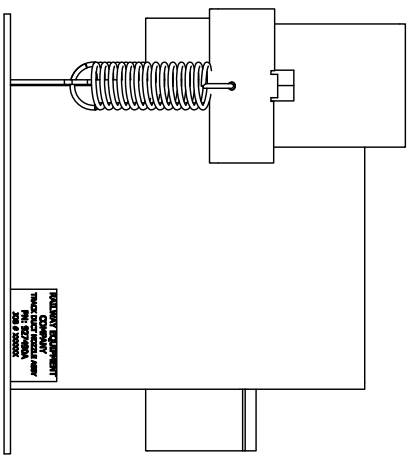
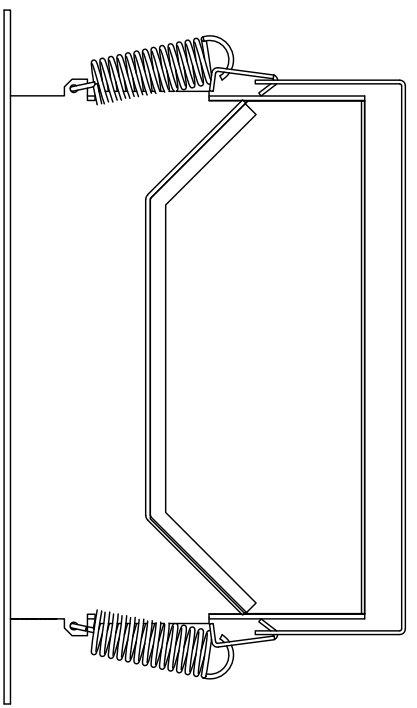
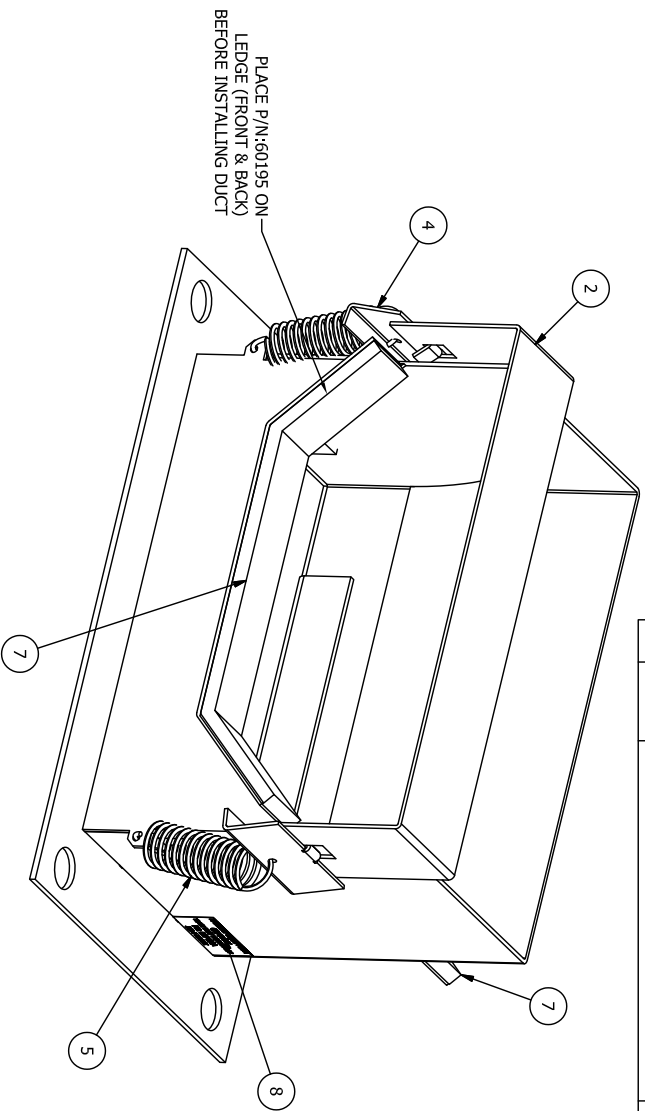
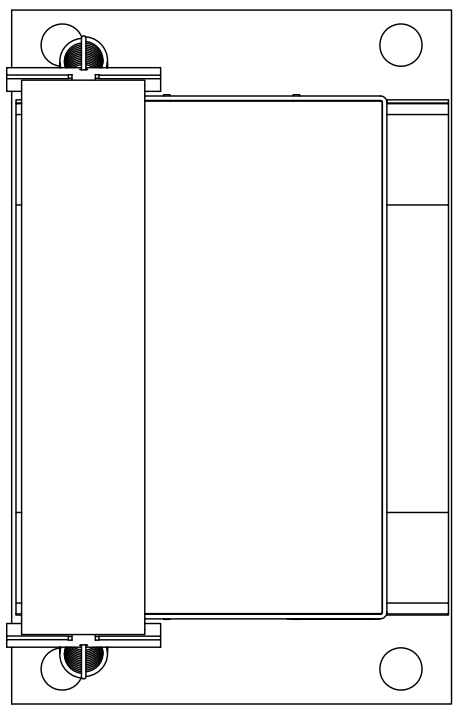

REV	ECO	DESCRIPTION	DATE	BY
A	06-0028	NEW PART	11/30/2006	RMJ

REVISION HISTORY

UNLESS OTHERWISE SPECIFIED:
DIMENSIONS ARE IN INCHES
DECIMALS ¹⁰⁰/₁₀₀₀ ANGULAR
X.X 4 0.02 FRACTIONS
3/16 0.03125
3/8 0.375
DRAWN: RMJ

DATE: 11/30/06
WRT: N/A
TENG: N/A
SCALE: 1/2
DWS: B
SHEET 1 OF 1

© RAILWAY EQUIPMENT CO. 2006
RAILWAY EQUIPMENT CO.
DELAWARE, KENTZESOTA (781) 972-4990

TITLE: NOZZLE, TRACK DUCT ASSY
DWG NO: 927490
REV: A

ITEM NO.	PART NO.	UOM	QTY	DESCRIPTION
1	2631851114	EA	4	BOLT, HEX HD 3/8-16 x 1" SS
2	2633-8110	EA	4	WASHER, PLAIN 3/8"
3	2633-90156	EA	4	WASHER, INSULATOR
4	26106	EA	4	SPACER, ROUND, .38 X .625 X .375
5	927570	EA	1	GASKET, POINT NOZZLE
6	2633-9014	EA	4	WASHER, 5/8 FLAT PLATED
7	14046	EA	1	BAG, ZIPTOP 9x12 4mil
8	2633-9210	EA	4	WASHER, SPLIT LOCK 3/8"
9	927701A	EA	1	SCREEN, POINT NOZZLE

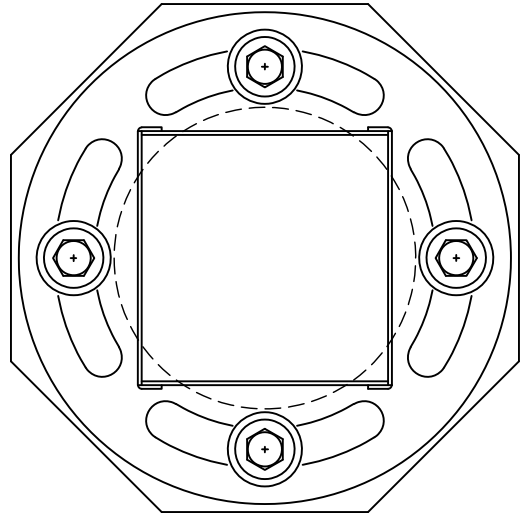
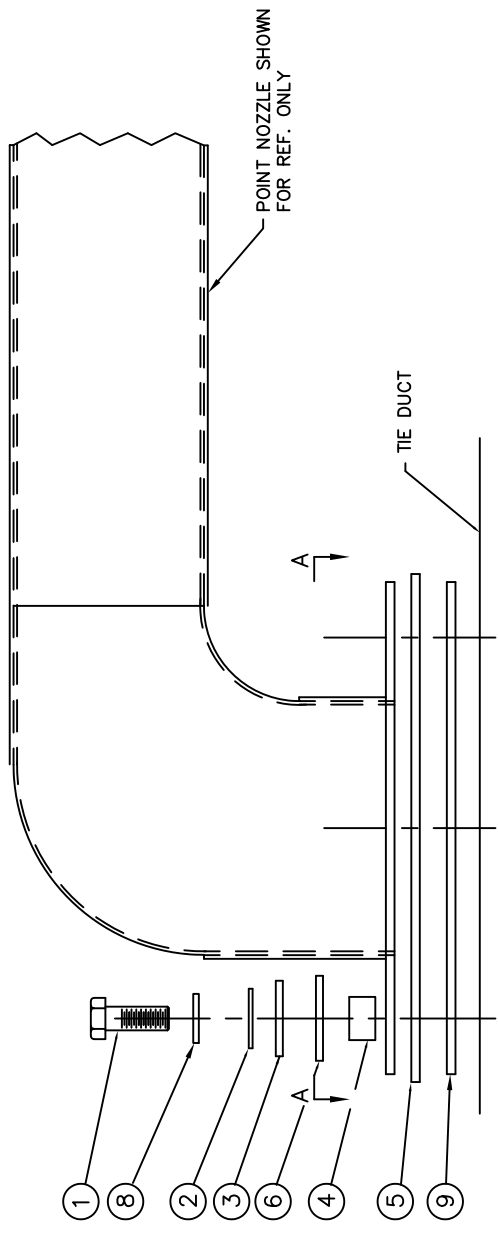

SECTION A-A

POINT NOZZLE SHOWN FOR REF. ONLY

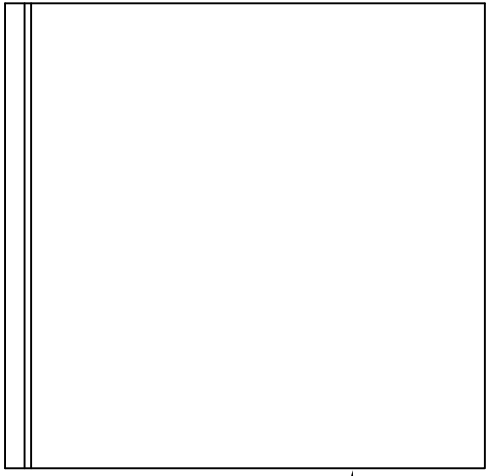

REV.	ECO.	BY	REVISION DESCRIPTION	DATE	APPROVED
B		TB	ADD 927701	10/19/00	
C	08-002B	RJ	CORNERS CUT OFF ON DUCT	11/28/06	

UNLESS OTHERWISE SPECIFIED:
 DIMENSIONS IN INCHES
 DECIMALS ARE TO BE ROUNDED UP
 FRACTIONS ARE TO BE ROUNDED UP
 DIMENSIONS TO FACE UNLESS NOTED OTHERWISE
 DIMENSIONS TO CENTER UNLESS NOTED OTHERWISE
 DIMENSIONS TO EDGE UNLESS NOTED OTHERWISE
 DIMENSIONS TO SURFACE UNLESS NOTED OTHERWISE
 DIMENSIONS TO CENTERLINE UNLESS NOTED OTHERWISE
 DIMENSIONS TO CENTER UNLESS NOTED OTHERWISE
 DIMENSIONS TO SURFACE UNLESS NOTED OTHERWISE
 DIMENSIONS TO CENTERLINE UNLESS NOTED OTHERWISE
 DIMENSIONS TO CENTER UNLESS NOTED OTHERWISE

DRAWN: EFK
 DATE: 04/11/97
 MATERIAL: N/A
 TIE & WELD ALLOWANCE: N/A

© RAILWAY EQUIPMENT CO. 1997-2002
RAILWAY EQUIPMENT CO.
 DELANO, MINNESOTA (763) 972-3500

TITLE: ISOLATION KIT ASSEMBLY
 POINT NOZZLE
 TIE DUCT

DWG NO. 9278-0021
 SCALE 1/4" DRAWING SIZE B SHEET 1 OF 1

ITEM NO.	PART NO.	UOM	QTY	DESCRIPTION
1	283185114	EA	4	BOLT, HEX, 3/8-16 x 1" SS
2	2833-8110	EA	4	WASHER, FLANG 3/8
3	2833-9015	EA	4	WASHER, INSULATOR
4	28106	EA	4	SPACER, ROUND, .36 X .625 X .375
5	92739	EA	1	GASKET, TRACK DUCT NOZZLE
6	60195	FT	1.67	GASKET, ADHESIVE, .25 X 1"
7	14045	EA	1	BAG, ZIPTOP 12 X 13 4M6
8	2833-8210	EA	4	WASHER, SPLIT LOCK 3/8
9	927702	EA	1	SCREEN, TRACK DUCT NOZZLE
10	927702	EA	1	SCREEN, ISO KIT, TRACK NOZZLE
11	R92780027A	EA	1	LABEL, BAG LABEL ISO KIT TRACK

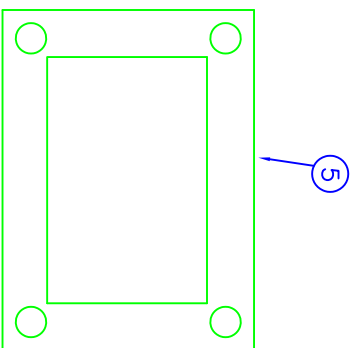
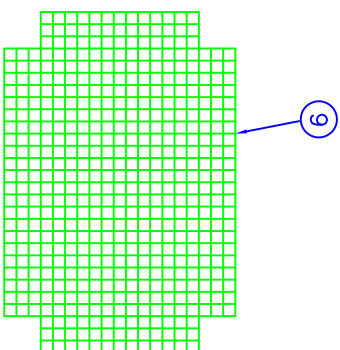
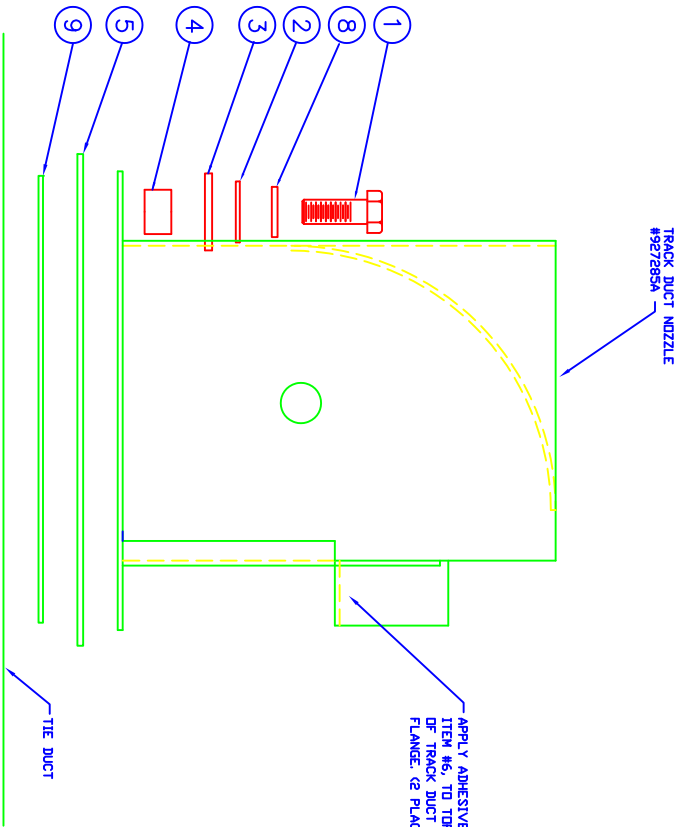
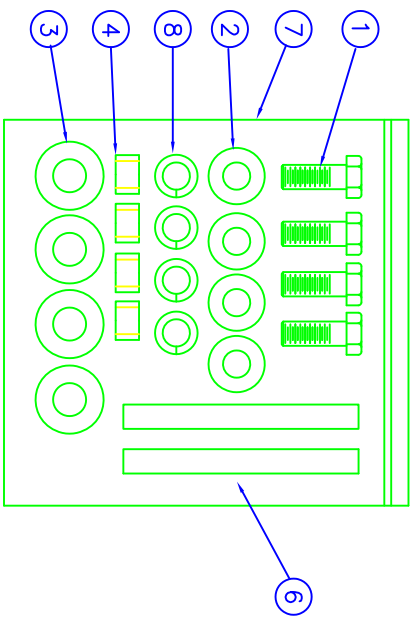

REV	SCALE	BY	DATE	DESCRIPTION	DATE	APPROVED
A	005	TB		NEW PART	12/29/00	

FORMED MATERIAL	DATE	12/19/00	DATE	12/19/00
APPROVED BY	DATE		APPROVED BY	DATE
DESIGNED BY	DATE		DESIGNED BY	DATE
CHECKED BY	DATE		CHECKED BY	DATE
DATE	DATE		DATE	DATE
1	of 1			

© RAILWAY EQUIPMENT CO. 2000
RAILWAY EQUIPMENT CO.
 BAZZAN, MISSOURI (781) 675-8800
 ASSY, ISO KIT
 TRACK NOZZLE
 TIE DUCT
 9278-0027

REVISION HISTORY			
REV	ECO	DESCRIPTION	DATE
A	06-0028	NEW PART	10/9/06
			BY WS

Parts List			
ITEM	PART NUMBER	REV / UOM / QTY	DESCRIPTION
1	14046	EA 1	BAG, 9 X 12 4MIL ZIPTOP
2	14150	EA 1	BAG, BURLAP 10" X 14" 100Z
3	14151	EA 2	WIRE BURLAP BAG CLOSING TIES 6"
4	14153	EA 1	BAG, WOVEN YELLOW 23.5 X 48
5	2831-9511	EA 4	BOLT, 3/4-10 X 8 HEX TAP
6	2831951121	EA 24	BOLT, 1/2-13 X 1.25 HEX SS
7	2832-9002	EA 24	NUT, 1/2-13 HEX
8	2832-9102	EA 12	NUT, 3/4-10 HEX
9	2833-9002	EA 24	Helical Spring Lock Washer
10	2833-9009	EA 12	WASHER, 3/4 SPLIT LOCK
11	2833-9010	EA 12	WASHER, 3/4 FLAT
12	60169	EA 1	TY-RAP, 0.30 X 8
13	92852B	B EA 4	UPRIGHT LEG SHORT FOUNDATION
14	92855B	B EA 2	BASE FOUNDATION
15	92856C	C EA 2	TOP 6HP FOUNDATION
16	92859B	B EA 2	FOUNDATION SUPPORT BRACE LARGE
17	R9288-0300	A EA 1	INSTRUCTION SHEET FOUNDATION

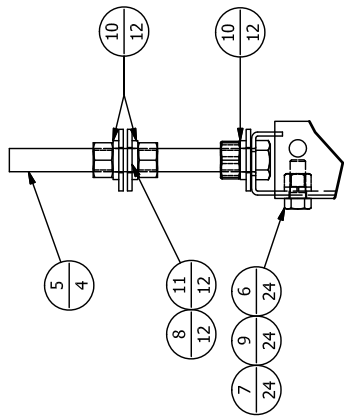

DETAIL A
SCALE 1 / 4

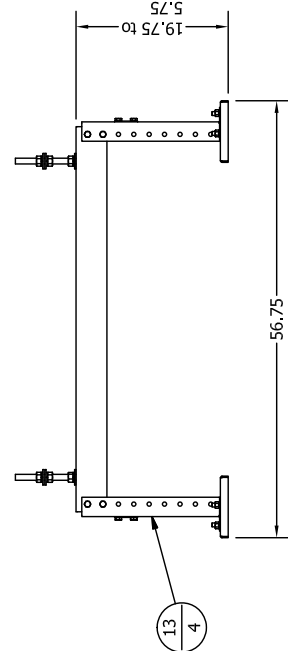
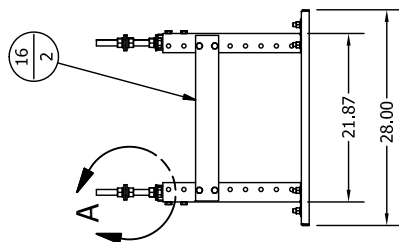
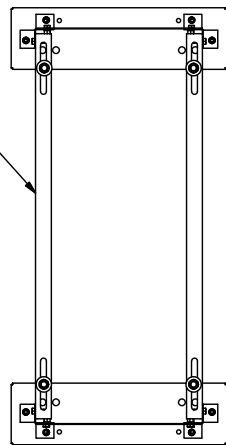
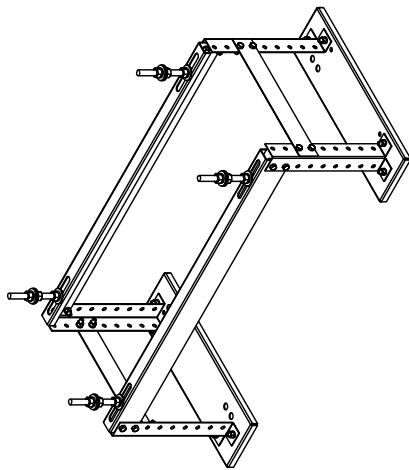

UNLESS OTHERWISE SPECIFIED:
DIMENSIONS ARE IN INCHES
DECIMALS - FRACTIONS
.XX - .99 FRACTIONS
DO NOT SCALE DRAWING

DRAWN: WS

DATE: 10/9/06

NOTE: SEE B.O.M.

SCALE: 1/16

SCALE: 1/16

DATE: 10/9/06

DWG NO: 9288-0302

REV: A

SCALE: 1 OF 1

© RAILWAY EQUIPMENT CO. 2006

RAILWAY EQUIPMENT CO.
DELAWARE, MINNESOTA (763) 876-5800

TITLE: FOUNDATION ASSY, 5HP GHAB
(ASSEMBLY)

ITEM PART NUMBER	REV	UOM	QTY	DESCRIPTION
1	952813A	A	EA	COVER, ACCESS 952 BURNER
2	952817	A	EA	PLATE, SAIL SWITCH & PRESSURE
3	952816	A	EA	COVER, SAIL SWITCH ON MAXON
4	9338-0072	A	EA	ASSY, DUCT PRESSURE SENSOR
5	60002	-	EA	3/8 ROMEX REGAL 6623
6	9338-0032	D	EA	AIR FLOW SWITCH EHAB/HP/HP
7	950132	B	EA	DUCT, 18X12X4 FLAME DUCT
8	952810	B	EA	INSUL COVER, REDUCER WRAP
9	952811	A	EA	INSUL BASE, REDUCER WRAP
10	60061	-	FT	CONDUIT, FLEX 3/4 INCH STEEL
11	60093	-	EA	CONDUIT, FLEX CONNECTOR
12	60071	-	EA	CONDUIT, FLEX CONNECTOR
13	29051	-	EA	BOLT, 1/4-20 X 1/2 HHW X 1/2 HD
15	283141108	-	EA	SCREW, #8-32 X 1/2 PAN SLT
16	283131104	-	EA	SCREW, #8-32 X 1/4 PAN SLT
17	29019	-	EA	SHOULDER BOLT 1/4-20 X 1.3
18	283185116	-	EA	BOLT, 3/8-16 X 1 HEX CAP
19	14045	-	EA	BAG, 12 X 15 4MIL ZIPTOP
20	2832-8904	-	EA	NUT, 3/8-16 CENTERLOCK
21	2833-3200	-	EA	WASHER, #8 SPLITLOCK
22	32002	-	SCF	INSULATION, FIBERGLASS
23	93825	B	EA	GASKET, 9 X 9 LIFT-OUT
24	9538-0049	A	FT	ASSY, AIR FLOW WIRES 5HP HIGH
25	9538-0039	A	FT	ASSY, DUCT SENSOR EXT CABLE

Parts List

REVISION HISTORY			
REV	ECO	DESCRIPTION	DATE
A	06-0027	NEW PART	10/10/2006

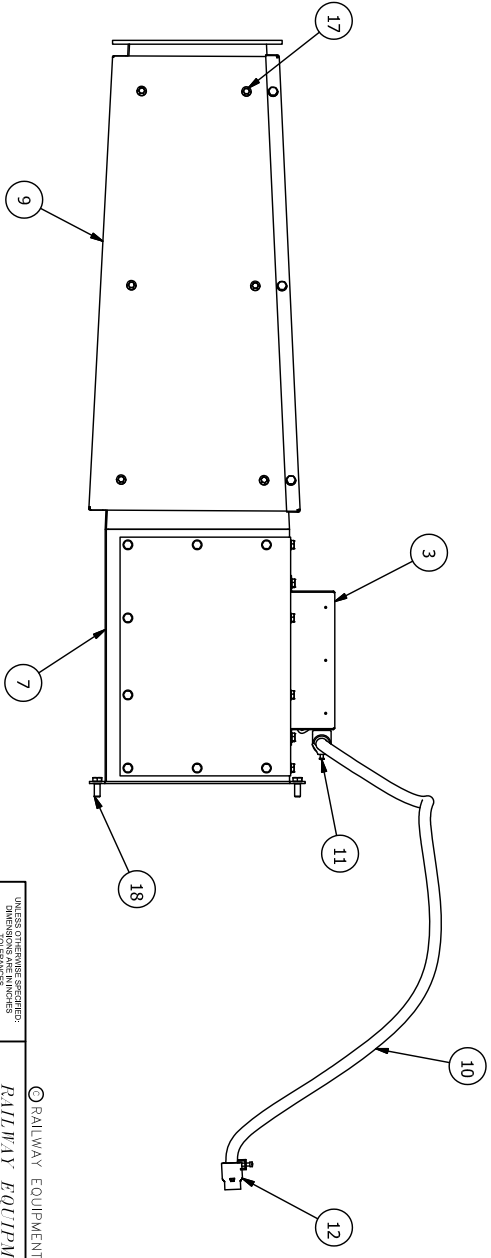
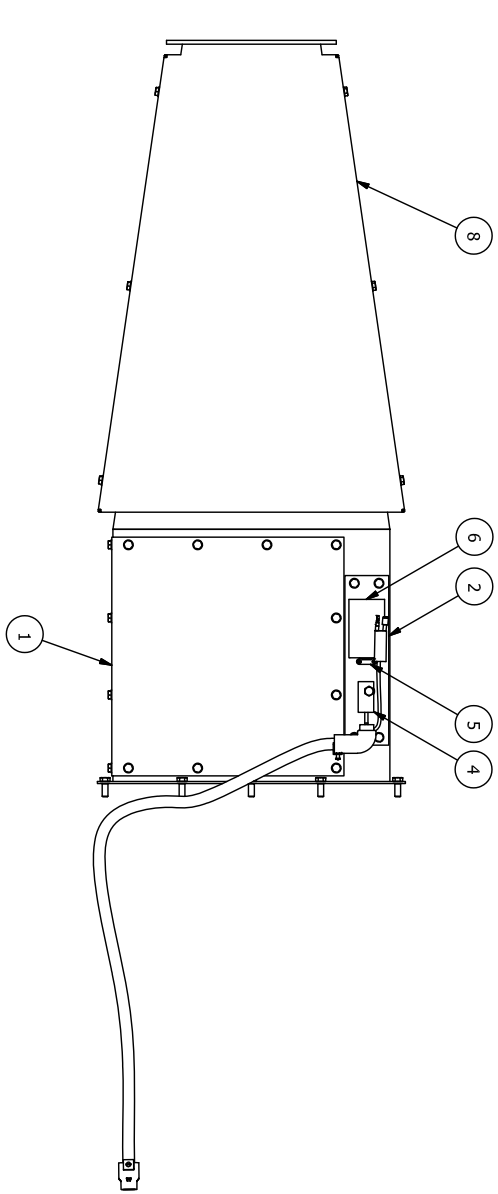

UNLESS OTHERWISE SPECIFIED:
 DIMENSIONS ARE IN INCHES
 DECIMALS TO THREE PLACES
 FRACTIONS TO SIXTEENTHS
 ANGULAR DIMENSIONS TO NEAREST MINUTE
 HOLE DIMENSIONS TO NEAREST THOUSITH

DATE: 10-10-06
 DWG NO: 9528-3102
 SCALE: 1/4" = 1"

RAILWAY EQUIPMENT CO. 2006
 BELLEVILLE, MISSOURI (763) 972-4299

TITLE: ASSY, FLAME DUCT, 5HP W/ SENSOR

DRAWN: RMJ
 CHECKED: N/A
 DATE: 10-10-06
 DWG NO: 9528-3102
 SCALE: 1/4" = 1"

REVISION: A
 SHEET 1 OF 1

REV	ECO #	DESCRIPTION	DATE	BY
A	03-0056	NEW PART	9/18/2003	JK
B	16-0015	MATERIAL CHANGE TO TOP OF DUCT	10/20/2016	JT

ITEM	PART NUMBER	REV	QTY	UOM	DESCRIPTION
1	29019	-	8	EA	BOLT, 1/4-20 X 1.3 SHOULDER THREAD ROLLING
2	32002	-	5	SQFT	INSULATION, FIBERGLASS
3	6093-0102	-	1	EA	TY-RAP
4	9278-0026C	C	1	EA	ASS, FLEX DUCT BOLT KIT
5	933225B	B	1	EA	DUCT, OFFSET, WITH HEAVY BASE
6	933226B	B	1	EA	INSUL COVER, OFFSET DUCT
7	R9278-3402B	B	1	EA	LABEL, ID

PARTS LIST

REVISION HISTORY

6 2

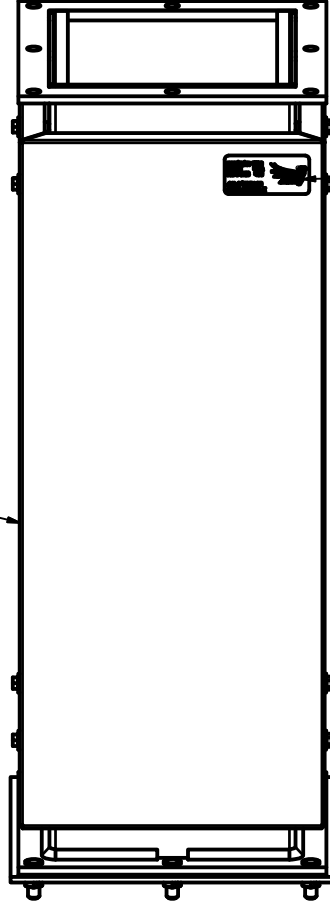

7

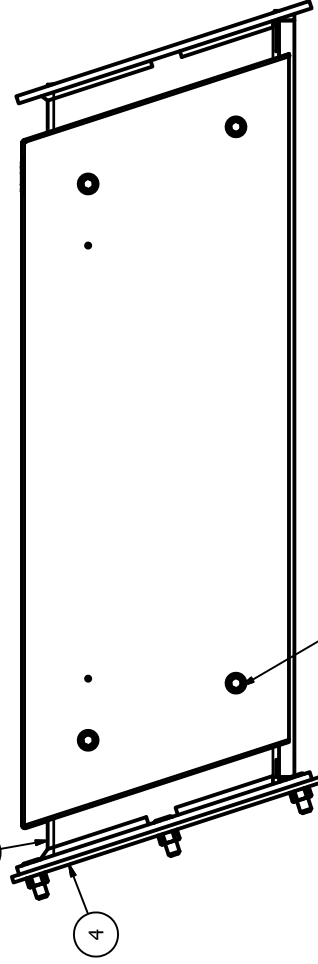

1

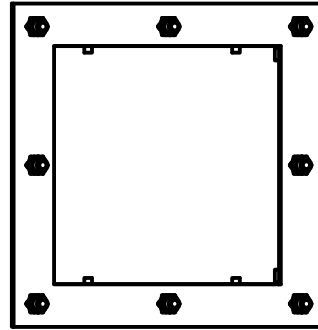

UNLESS OTHERWISE SPECIFIED:
 DIMENSIONS ARE IN INCHES
 DECIMALS FRACTIONS ANGULAR
 .XX # 0/10 FRACTIONS
 .XXX # 0/100 FRACTIONS
 .XXX # 0/1000 FRACTIONS
 .XXX # 0/1000 FRACTIONS
 .XXX # 0/1000 FRACTIONS

TITLE: DUCT, OFFSET, 2' HD NO MIXER
 DRAWING NO: 9278-3402B
 DATE: 10/20/2016
 BY: JT
 CHECKED: B
 SCALE: 1/8" = 1'-0"
 SHEET: 1 OF 1

© RAILWAY EQUIPMENT CO. 2016
RAILWAY EQUIPMENT CO.
 1000 W. 10TH ST. ST. LOUIS, MO 63103
 (314) 487-8800

PARTS LIST					
ITEM	PART NUMBER	REV	QTY	UOM	DESCRIPTION
1	29051	-	6	EA	BOLT, 1/4-20 X 1/2 WITH 1/2 HD
2	32002	A	8	SQ.FT.	INSULATION, FIBERGLASS
3	6093-0102	-	1	EA	TY-RAP
4	952244	A	1	EA	FLEX WRAP, TOP 2 FOOT
5	952245	A	1	EA	FLEX WRAP, BOTTOM 2 FOOT
6	952709	A	1	EA	DUCT, FLEX, 2 STRAIGHT
7	9528-0074	B	1	EA	GASKET KIT, 9X9 SHP FLEX
8	R9528-4220A	A	1	EA	LABEL, ID

REVISION HISTORY			
REV	ECO #	DESCRIPTION	DATE
A	03-0066	NEW PART	10/21/2003

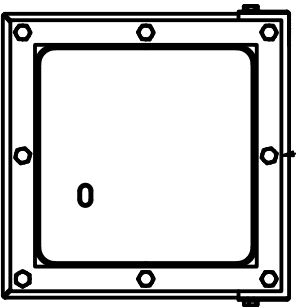
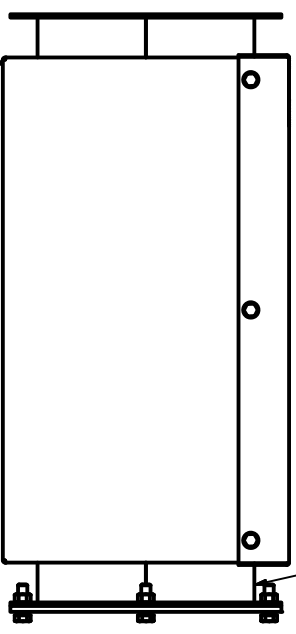
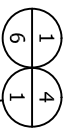
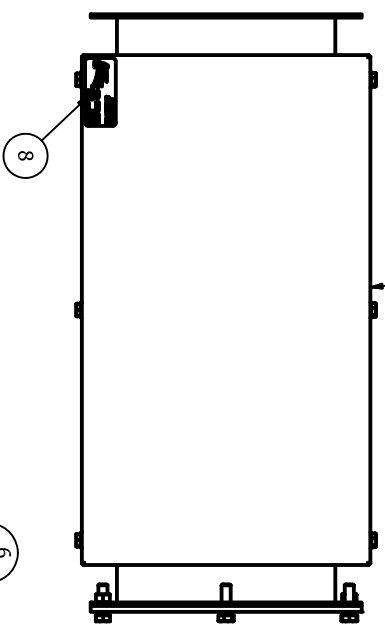
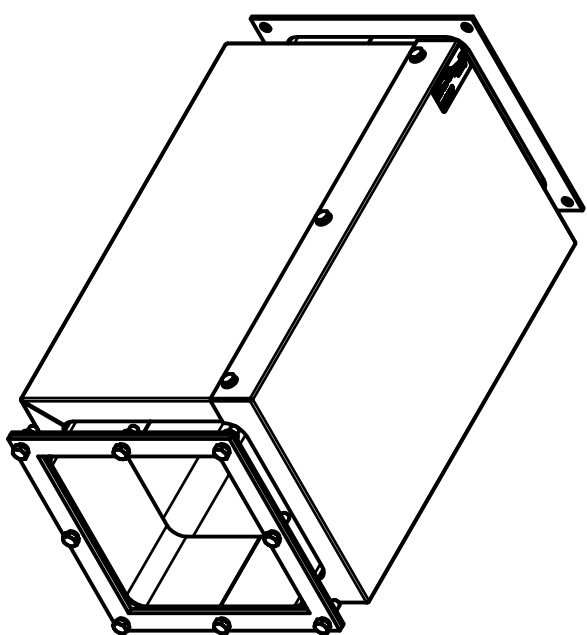

RAILWAY EQUIPMENT CO. 2016

RAILWAY EQUIPMENT CO.
 1800 WEST 10TH AVENUE
 DENVER, COLORADO 80202 (303) 733-4000

UNLESS OTHERWISE SPECIFIED:
 DIMENSIONS DECIMALS ANGULAR
 TOLERANCES FRACTIONS
 .XX & .010 .030
 .XX & .010 .030
 .XX & .010 .030

DRAWN: MMUJUN
 DATE: 7/8/2016
 PART: FLEX DUCT, INSULATED 2' STRAIGHT
 DWG NO: 9528-4220
 SCALE: DIMS: B SHEET 1 OF 1

REVISION HISTORY			
REV	ECO #	DESCRIPTION	DATE
A	-	NEW PART	5/24/2005

PARTS LIST			
ITEM	PART NUMBER	REV	DESCRIPTION
1	29051	-	BOLT, 1/4-20 X 1/2 WITH 1/2 HD
2	92740	F	END PLATE, TRACK DUCT
3	92741	E	TRACK DUCT COVER, 10'
4	927539A	A	TRACK DUCT BASE, 10' W/HOLE
5	92774K	K	TRACK DUCT SUPPORT BRACKET
6	92785E	E	DEFLECTOR, TRACK DUCT SML

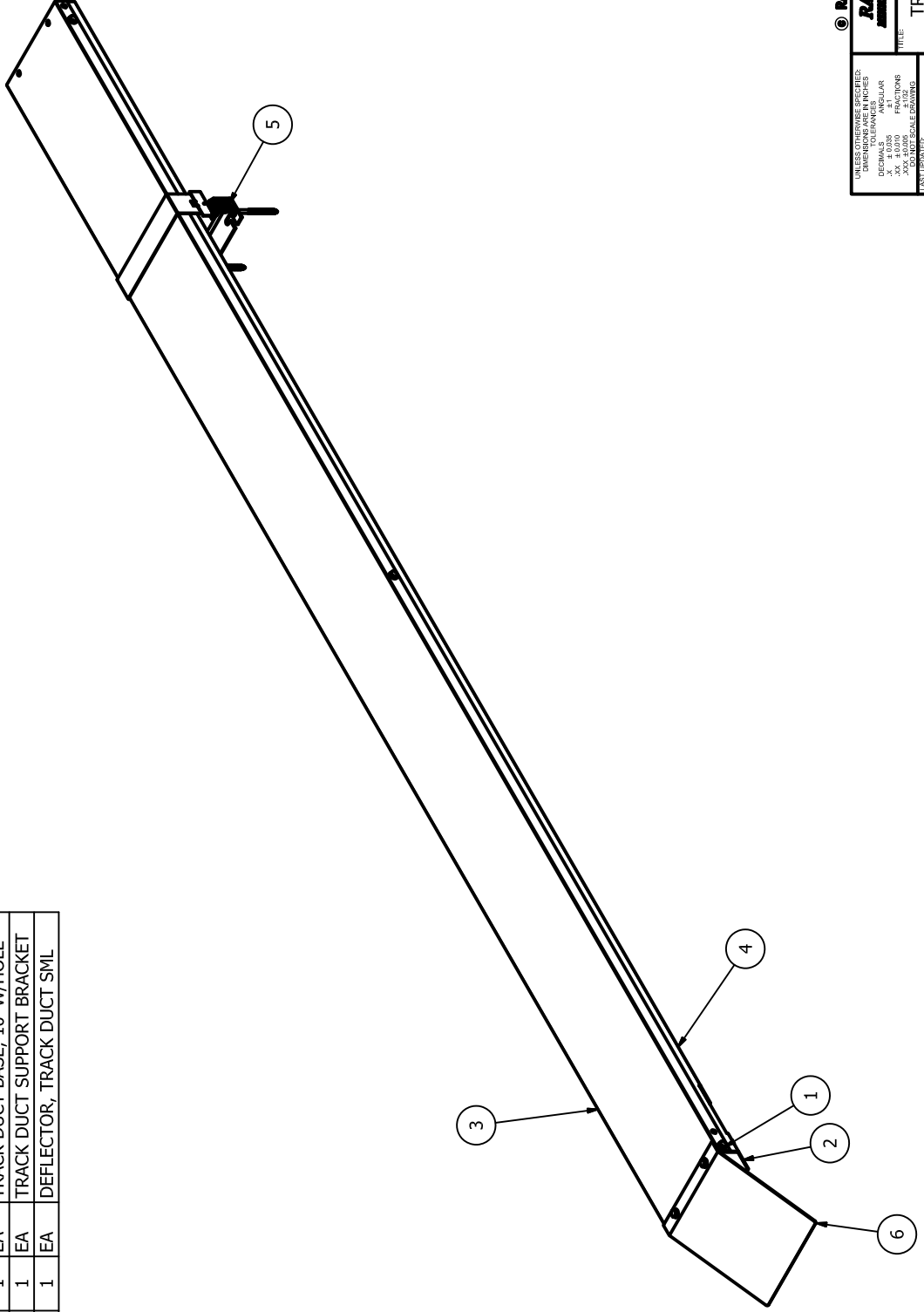

UNLESS OTHERWISE SPECIFIED:
 DIMENSIONS IN INCHES
 DECIMALS TO THIRDS
 ANGULAR TOLEANCES
 FRACTIONS TO THIRDS
 .XX ± 0.010
 .XX ± 0.015
 .XX ± 0.020
 .XX ± 0.030
 .XX ± 0.040
 .XX ± 0.050

TITLE: TRACK DUCT POINT, LARGE NOZZLE 10' SECTION

DATE: 5/29/2020
 BY: cwanderson

DRAWN BY: NA
 CHECKED BY: NA

SCALE: 1/8" = 1'-0"
 SHEET: 1 OF 1

© RAILWAY EQUIPMENT CO. 2020
RAILWAY EQUIPMENT CO.
 1000 W. 10th Street, Minneapolis, MN 55415
 (763) 489-4999

PARTS LIST					
ITEM	PART NUMBER	REV	QTY	UOM	DESCRIPTION
1	29051	-	6	EA	BOLT, 1/4-20 X 1/2 WITH 1/2 HD
2	92730A	A	1	EA	TRACK DUCT COVER, 5FT
3	92735B	B	1	EA	TRACK DUCT BASE, 5 FOOT LTD
4	927441	A	1	EA	CENTER COVER, E Z SPLICE
5	927442	A	2	EA	END COVER, E Z SPLICE
6	927450B	B	1	EA	BASE, E Z SPLICE
7	92774K	K	1	EA	TRACK DUCT SUPPORT BRACKET

REVISION HISTORY				
REV	ECO #	DESCRIPTION	DATE	BY
A	05-0017	NEW SPLICE SYSTEM	5/24/2005	RF
B	05-0047	NEW SUPPORT ASSM DESIGN	10/27/2005	RO
-	-	PN 927450A TO B	3/4/2020	CA

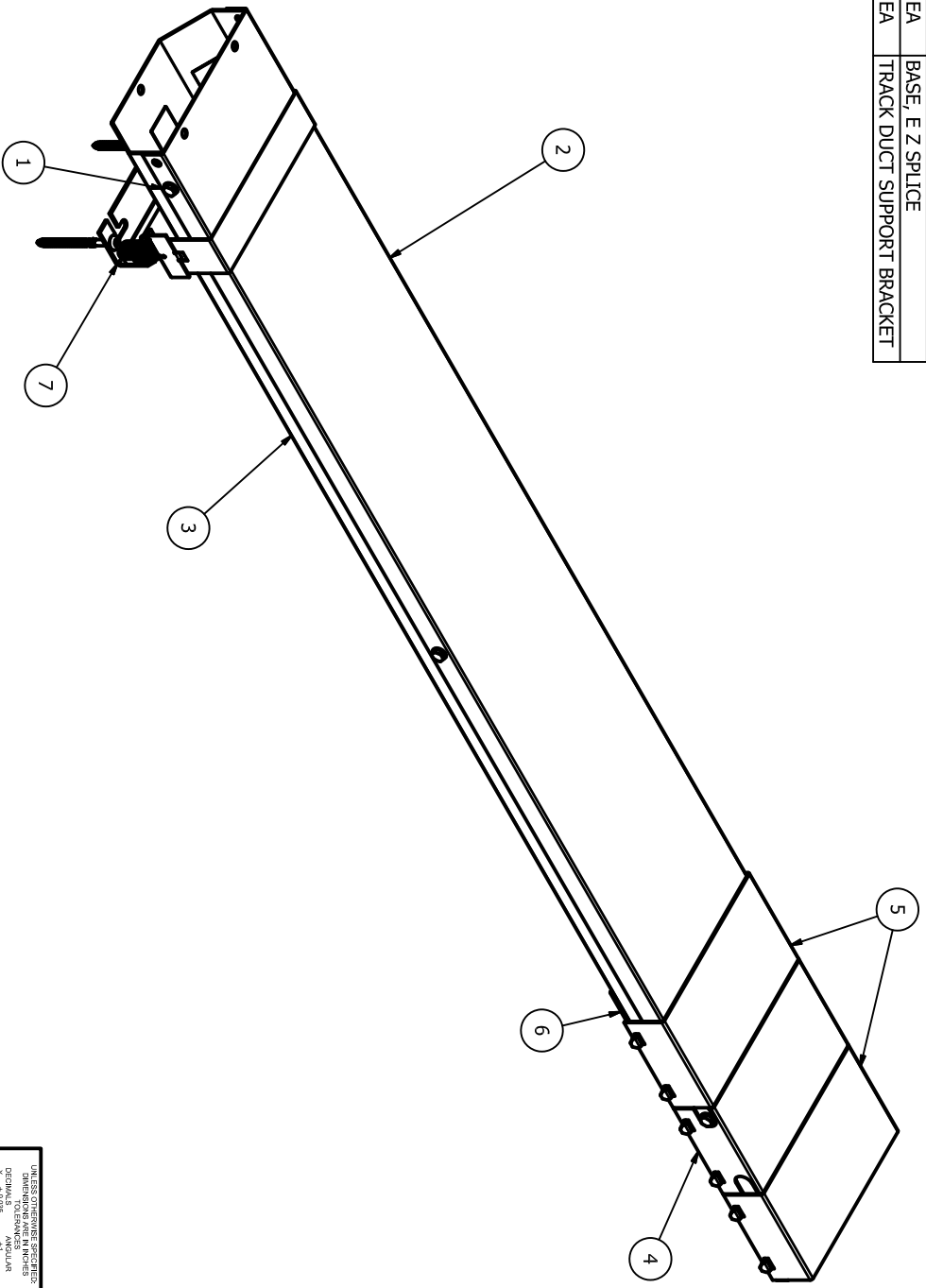

© RAILWAY EQUIPMENT CO. 2020

RAILWAY EQUIPMENT CO.
 10000 W. 10th Street, Suite 100
 Overland Park, Kansas 66211 (913) 666-4400

UNLESS OTHERWISE SPECIFIED:
 DIMENSIONS ARE IN INCHES
 DECIMALS ANGULAR
 XX .0010 FRACTIONS
 3/16 INCHES SCALE DRAWINGS

DATE: 3/4/2020
 DRAWN BY: gwanderson
 CHECKED BY: NA
 TITLE: TRACK DUCT 5' MID
 DWG NO: 9278-0227B
 SCALE: 1/5
 SHEET: 1 OF 1

REV	ECO #	DESCRIPTION	DATE	BY
J	-	REMOVE 92744, 28080, 28081	5/26/1999	TB
K	02-0045	REPLACE 29016 W/ 29051	8/29/2002	RF
L	05-0017	NEW SPLICE SYSTEM	5/18/2005	RF
M	05-0047	NEW SUPPORT ASSEM. DESIGN	10/27/2005	RO
-	-	PN 927450A TO B	3/4/2020	CA

ITEM	PART NUMBER	REV	QTY	UOM	DESCRIPTION
1	29051	-	6	EA	BOLT, 1/4-20 X 1/2 WITH 1/2 HD
2	92741	E	1	EA	TRACK DUCT COVER, 10'
3	927441	A	1	EA	CENTER COVER, E Z SPLICE
4	927442	A	2	EA	END COVER, E Z SPLICE
5	927450B	B	1	EA	BASE, E Z SPLICE
6	927538	A	1	EA	TRACK DUCT BASE, 10' NO HOLE
7	92774K	K	1	EA	TRACK DUCT SUPPORT BRACKET

PARTS LIST	
ECO #	DESCRIPTION
-	REMOVE 92744, 28080, 28081
02-0045	REPLACE 29016 W/ 29051
05-0017	NEW SPLICE SYSTEM
05-0047	NEW SUPPORT ASSEM. DESIGN
-	PN 927450A TO B

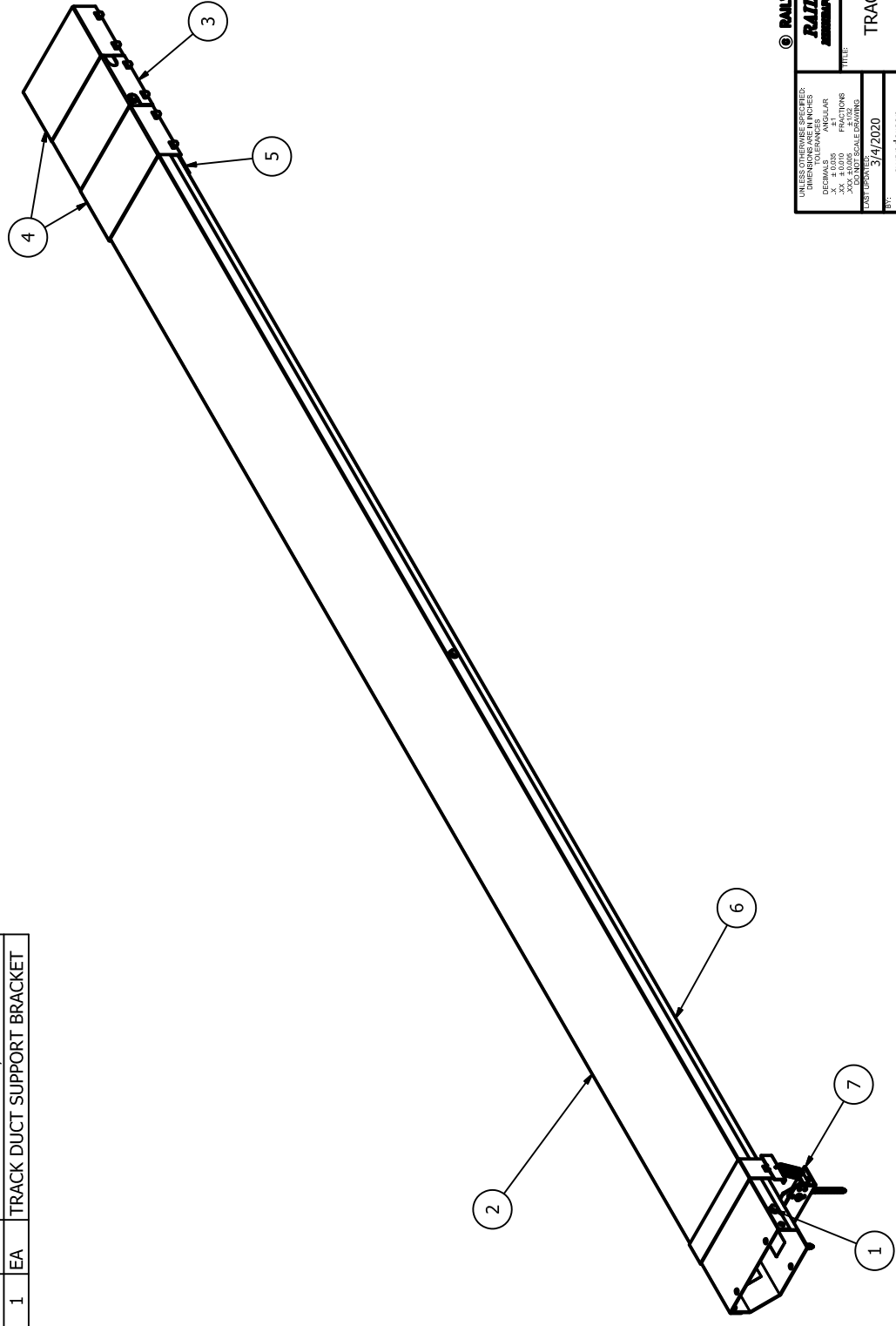

© RAILWAY EQUIPMENT CO. 2020
RAILWAY EQUIPMENT CO.
 ANNUALVILLE, OHIO 43015
 (614) 699-3300

UNLESS OTHERWISE SPECIFIED:
 DIMENSIONS IN INCHES
 DECIMALS TO THIRDS
 ANGULAR TO NEAREST MINUTE
 FRACTIONS TO NEAREST 1/32
 HOLE DIMENSIONS TO NEAREST 1/32
 TOLERANCES UNLESS OTHERWISE SPECIFIED:
 FRACTIONS TO NEAREST 1/32
 DECIMALS TO NEAREST 0.005
 DIMENSIONS TO NEAREST 0.005

DATE: 3/4/2020
 DRAWN BY: cvanderson
 PART: NA
 REV: 1
 SCALE: 1/8
 SHEET: 1 OF 1

TITLE: TRACK DUCT SECTION, MID
 PART NO: 9278-1201M
 REV: M

PARTS LIST					
ITEM	PART NUMBER	REV	QTY	UOM	DESCRIPTION
1	29051	-	11	EA	BOLT, 1/4-20 X 1/2 WITH 1/2 HD
2	92740	F	1	EA	END PLATE, TRACK DUCT
3	92741	E	1	EA	TRACK DUCT COVER, 10'
4	927441	A	1	EA	CENTER COVER, E Z SPLICE
5	927442	A	2	EA	END COVER, E Z SPLICE
6	927450	A	1	EA	BASE, E Z SPLICE
7	927538	A	1	EA	TRACK DUCT BASE, 10' NO HOLE
8	92774K	K	1	EA	TRACK DUCT SUPPORT BRACKET
9	92785	D	1	EA	DEFLECTOR, TRACK DUCT SML

REVISION HISTORY				
REV	ECO #	DESCRIPTION	DATE	BY
J	-	UPDATE TRACK DUCT SUPPORT	5/26/1999	TB
K	02-0045	REPLACE 29016 W/ 29051	8/29/2002	RF
L	05-0017	NEW SPLICE SYSTEM	5/18/2005	RF
M	05-0047	NEW SUPPORT ASSEM. DESIGN	10/27/2005	RO
-	-	PN 927450A TO B	3/4/2020	CA

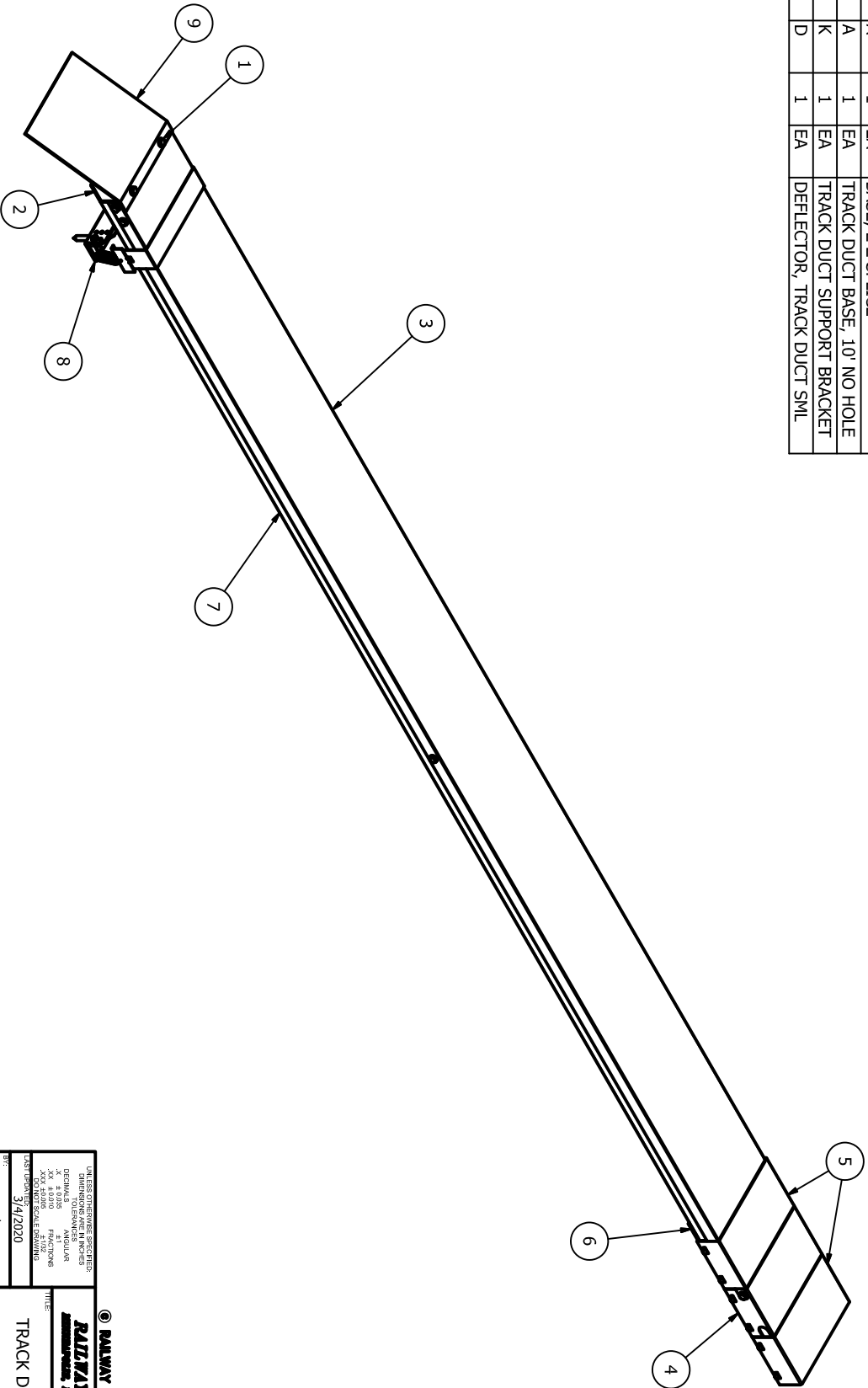

RAILWAY EQUIPMENT CO. 2020

RAILWAY EQUIPMENT CO.
 1000 W. 10th Street, Suite 100
 Grand Rapids, MI 49503
 (616) 941-4400

TITLE: TRACK DUCT SECTION, HEEL

DATE: 3/4/2020

DESIGNER: Gwunderson

DRAWN BY: Gwunderson

CHECKED BY: Gwunderson

SCALE: 1/8" = 1'-0"

SHEET: 1 OF 1

REV	ECO #	DESCRIPTION	DATE	BY
A	08-0009	NEW PART	6/18/2008	JB
B	11-0036	12.5' HOSE	04/25/11	GLJ
C	-	NOZZLE ASSEMBLY CHANGED	9/25/15	BF
D	-	SHORTENED NOZZLE	3/11/16	BF
		ADDED R9278-95000		

ITEM	PART NUMBER	REV	UOM	QTY	DESCRIPTION
1	14045	-	EA	1	BAG, 12 X 15 MIL ZIPTOP
2	1491-0704	-	EA	3	CONDUIT 2IN RIGID 2 HOLE STRAP
3	28039	-	EA	3	CAP, PLASTIC, 2IN TAPERED
4	28106	-	EA	4	SPACER, .38X.625X.375 ROUND
5	2832-8101	-	EA	4	NUT, 3/8-16 HEX
6	2833-8110	-	EA	4	WASHER, 3/8 FLAT
7	2833-8210	-	EA	4	WASHER, 3/8 SPLIT LOCK
8	2833-9015B	B	EA	4	WASHER, ISOLATING NOZZLE
9	29024	-	EA	6	BOLT, 1/4 X 1-1/2 LAG HEX
10	29051	-	EA	22	BOLT, 1/4-20 X 1/2 WITH 1/2 HD
11	32016	-	SQFT	.08	GASKET MATERIAL, 1/4" BLACK SILICONE RUBBER
12	600101	-	FT	1	HOSE, 2IN UNLINED INTERLOCKED GALVANIZED STEEL 12' 6" LONG EACH PIECE
13	60195	-	FT	1.67	GASKET, .25 X 1.0 ADHESIVE BK
14	927155A	A	EA	1	WELDMT, END PLATE, TRACK DUCT
15	92740F	F	EA	1	END PLATE, TRACK DUCT
16	92747B	B	EA	1	TRACK DUCT BOTTOM SECTION
17	92749A	A	EA	2	CAP, STEEL, 2IN ID
18	92753B	B	EA	1	COVER, TOP TRACK DUCT
19	927588B	B	EA	1	NOZZLE, TRACK DUCT, NO DAMPER
20	92759B	B	EA	1	GASKET, ISO, TR NOZZLE RED
21	927604B	B	EA	1	TRACK DUCT NOZZLE MOUNT PLATE
22	92760B	B	EA	1	DEFLECTOR, TRACK DUCT TUBE
23	927702A	A	EA	1	SCREEN TRACK DUCT NOZZLE LARGE
24	92785D	D	EA	1	DEFLECTOR, TRACK DUCT SML
25	R9278-95000	D	EA	1	LABEL, ID

Parts List

REVISION HISTORY

1
1

2
3

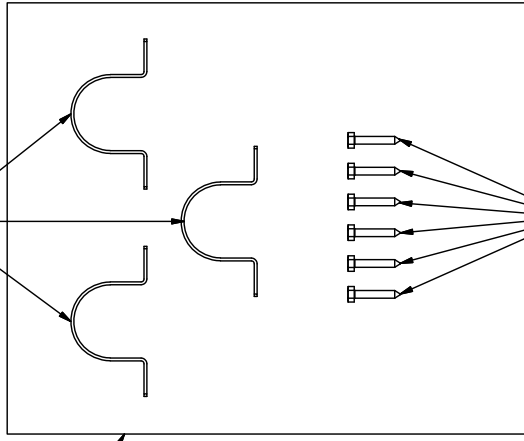

9
6

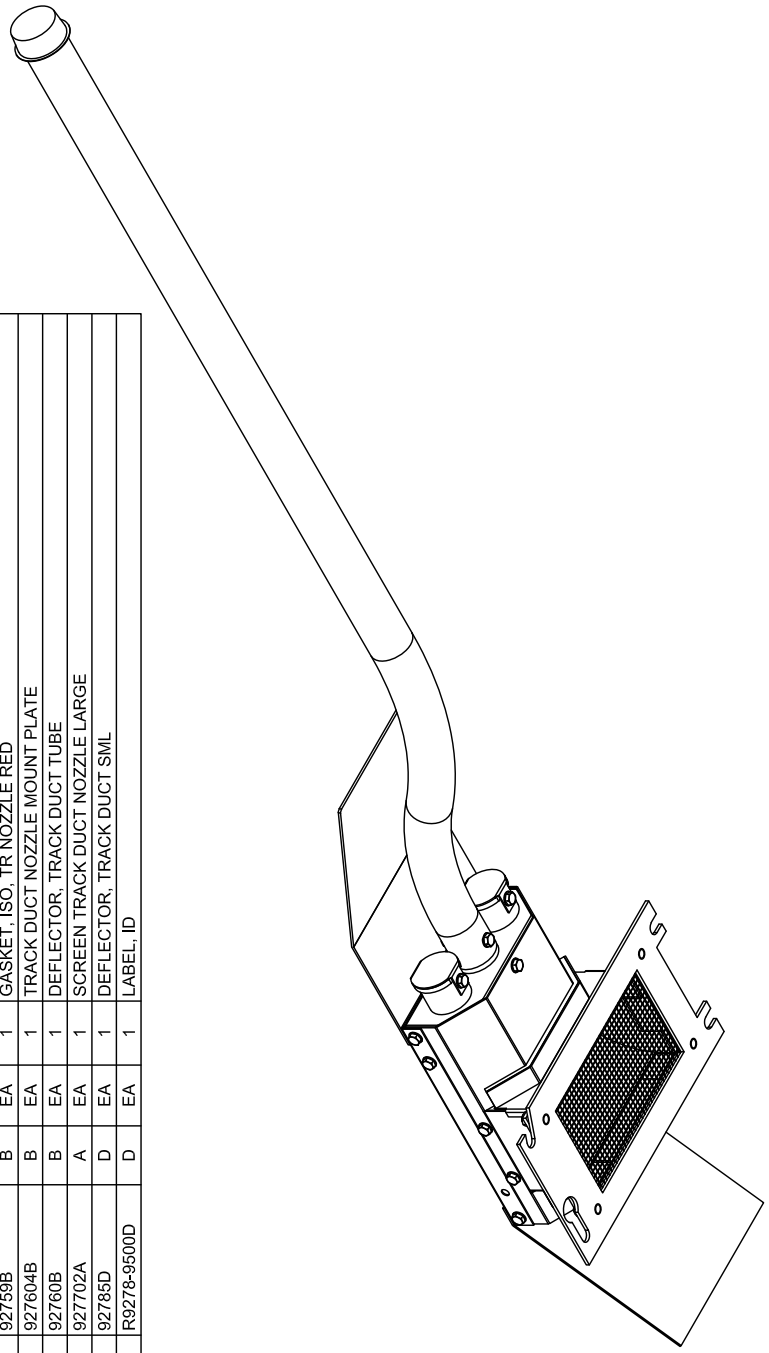

UNLESS OTHERWISE SPECIFIED:
 DIMENSIONS ARE IN INCHES
 DECIMALS - TYPICAL
 ANGULAR - .0015
 FRACTIONS - .0010
 .XX # 0.010
 .000 NOT SCALE DRAWING
 DRAWN: BF
 DATE: 3/11/16
 DWG NO: 9278-95000
 REVISION: N/A
 SCALE: 1:4
 DIM SIZE: B
 SHEET 1 OF 3

© RAILWAY EQUIPMENT CO. 2006
RAILWAY EQUIPMENT CO.
 DELAWARE, MINNESOTA (763) 978-5800
 TITLE: FLEX NOZZLE KIT (LTD)

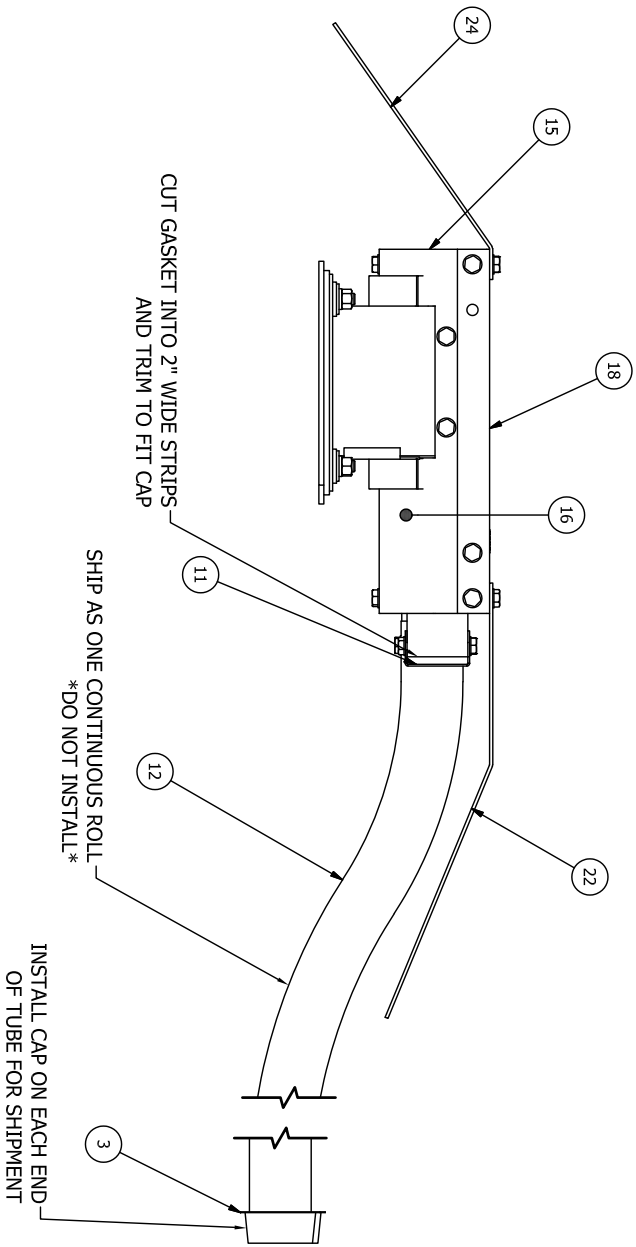
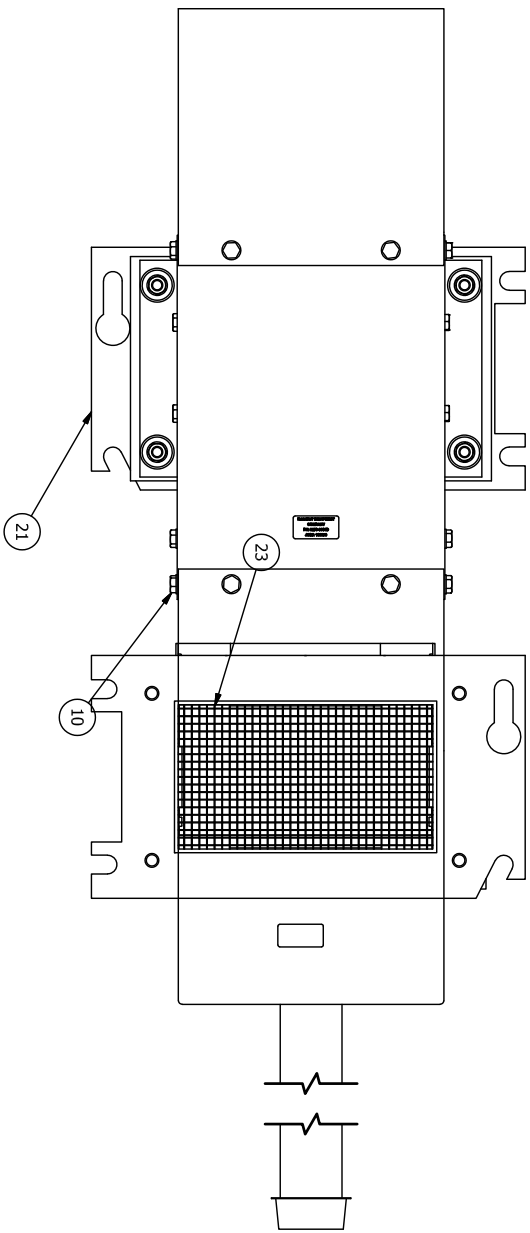

CUT GASKET INTO 2" WIDE STRIPS
AND TRIM TO FIT CAP

SHIP AS ONE CONTINUOUS ROLL
DO NOT INSTALL

INSTALL CAP ON EACH END
OF TUBE FOR SHIPMENT

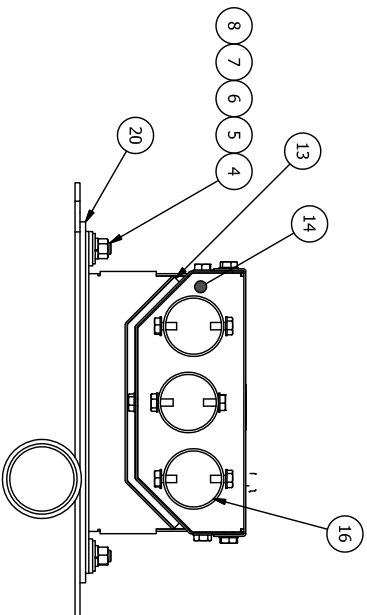

UNLESS OTHERWISE SPECIFIED: DIMENSIONS ARE IN INCHES DECIMALS ARE IN THOUSANDS		DRAWING NO. 9278-95000		REV. D
RAILWAY EQUIPMENT CO. DEALON, MINNESOTA (763) 973-2200		DATE: 3/11/16		SCALE: 1/4"
TITLE: FLEX NOZZLE KIT (LTD)		MATERIAL: B		SHEET 2 OF 3
PARTS LIST: ITEM NO. QTY. PART NO. DESCRIPTION		REVISIONS:		
DRAWN BY: BF		CHECKED BY:		
DATE: 3/11/16		APPROVED BY:		
MATERIAL: B		SCALE: 1/4"		SHEET 2 OF 3
REVISIONS:		DATE:		
REV. D		DATE:		

© RAILWAY EQUIPMENT CO. 2006

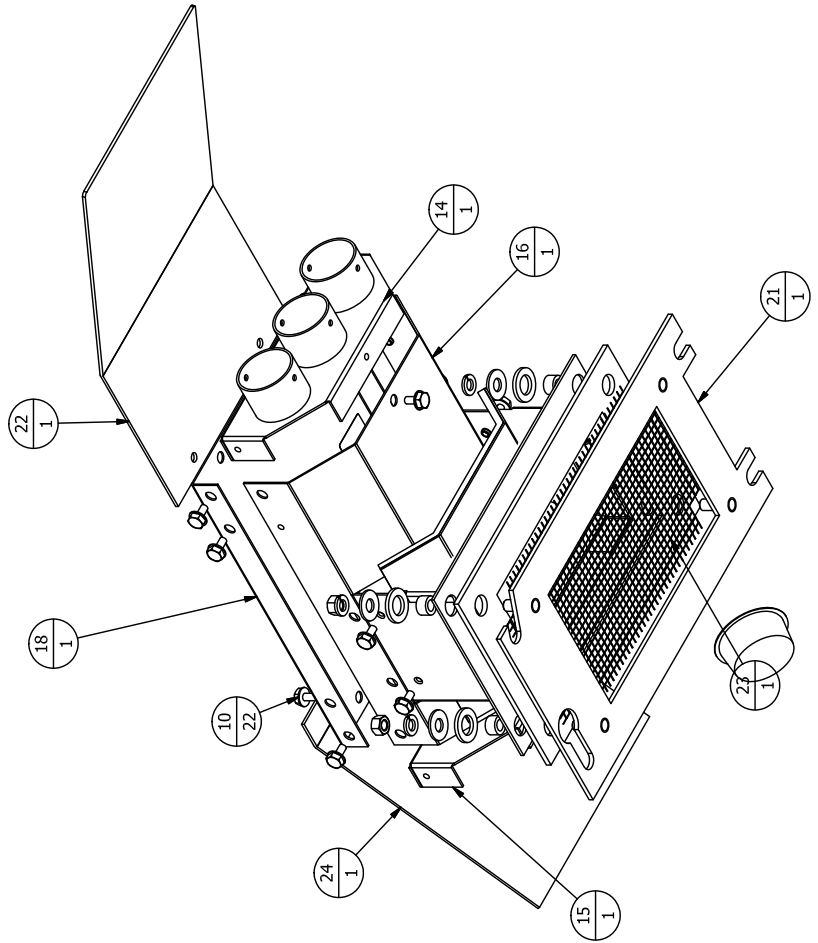
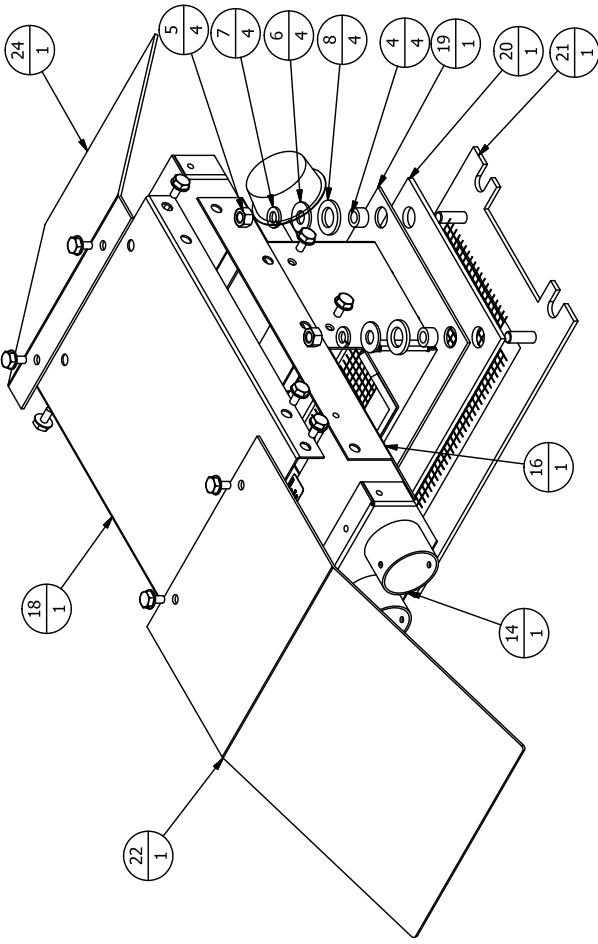

© RAILWAY EQUIPMENT CO. 2006

RAILWAY EQUIPMENT CO.
 DELAWARE, MINNESOTA (763) 978-5800

TITLE: FLEX NOZZLE KIT (LTD)

UNLESS OTHERWISE SPECIFIED:
 DIMENSIONS ARE IN INCHES
 DECIMALS - 1/1000ths
 ANGULAR - 1/16th
 FRACTIONS - 1/32
 HOLE DIMENSIONS - 1/32
 DO NOT SCALE DRAWING

DRAWN: BF

DATE: 4/6/16

REV: N/A

SCALE: N/A

DWG NO: 9278-9500D

REV: D

SCALE: B

SHEET 3 OF 3

ITEM	PART NUMBER	REV	UOM	QTY	DESCRIPTION
1	29051	-	EA	30	BOLT, 1/4-20 X 1/2 WITH 1/2 HD
2	6093-0100	-	EA	3	TY-RAP, 4IN 0.10 WIDTH
3	92740	F	EA	2	END PLATE, TRACK DUCT
4	92741	E	EA	3	TRACK DUCT COVER, 10'
5	927441	A	EA	2	CENTER COVER, E Z SPLICE
6	927442	A	EA	4	END COVER, E Z SPLICE
7	927450B	B	EA	2	BASE, E Z SPLICE
8	927538	A	EA	2	TRACK DUCT BASE, 10' NO HOLE
9	927539A	A	EA	1	TRACK DUCT BASE, 10' W/HOLE
10	92774K	K	EA	3	TRACK DUCT SUPPORT BRACKET
11	92785E	E	EA	2	DEFLECTOR, TRACK DUCT SML
12	R9278-0233B	B	EA	1	LABEL, 30' TRACK DUCT

PARTS LIST

REV	ECO #	DESCRIPTION	DATE	BY
A	-	NEW PART	11/16/09	ES
B	10-012	NEW PART	6/01/10	RH
-	-	PN 927450A TO B	3/4/2020	CA

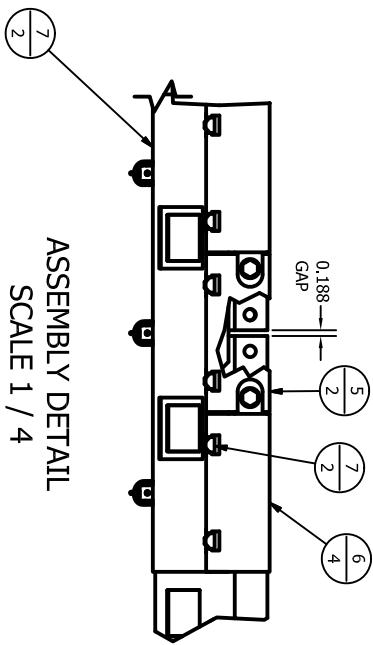
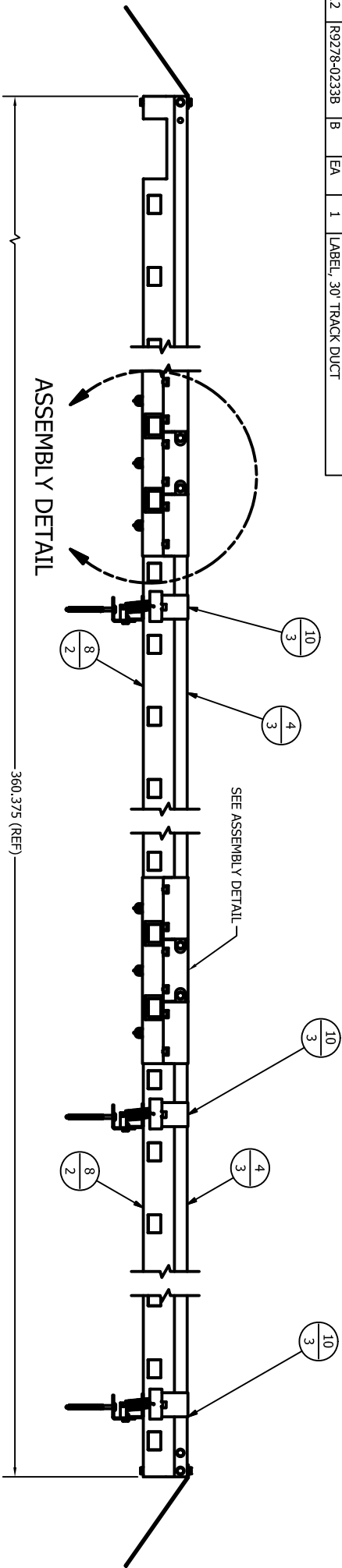

© RAILWAY EQUIPMENT CO. 2009

RAILWAY EQUIPMENT CO.
RAILWAY EQUIPMENT CO. (703) 595-0000

UNLESS OTHERWISE SPECIFIED:
DIMENSIONS ARE IN INCHES
DECIMALS .0005 ANGULAR
.001 .0010 FRACTIONS
30° UNLESS OTHERWISE STATED

DATE: 11/16/2009
DWG NO: 9278-0233B
REV: B
SCALE: 1" = 8' DIMENSIONS: B SHEET 1 OF 1

TITLE: TRACK DUCT 30'
WIDE TD NOZZLE/10' SECTIONS
(ASSEMBLY / B. O. M.)

ITEM NO.	PART NO.	UOM	QTY	DESCRIPTION
1	9278-0207	EA	1	TRACK DUCT KIT, 7' HEEL
2	9278-0027	EA	1	ISO KIT, TR NOZZLE, LARGE
3	927490	EA	1	NOZZLE, TRACK DUCT
4	41023	EA	1	BOX, TRACK DUCT KIT

REV.	Q.C.A.	BY	REVISION DESCRIPTION	DATE	APPROVED
A	02-0027	RF	NEW PART	07/03/02	----
B	03-0023	RF	UPDATE NOZZLE	07/29/03	----
C	05-0017	RF	NEW SPLICE DESIGN	05/25/05	----
D	05-0047	RO	NEW TRACK DUCT NOZZLE	11/10/05	----
E	06-0024	RJ	NEW TRACK DUCT NOZZLE	02/02/07	----

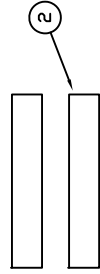
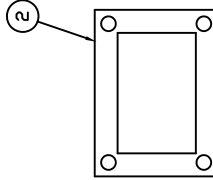
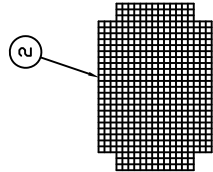
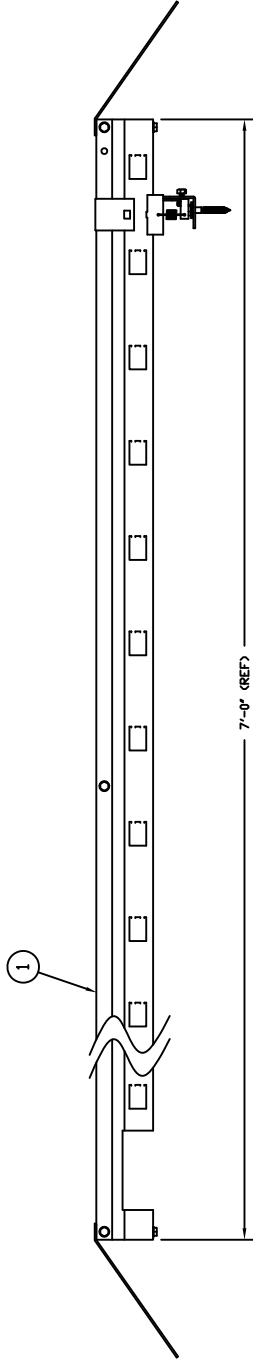
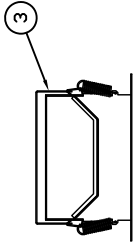
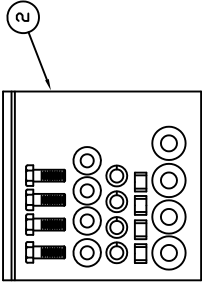

UNLESS OTHERWISE SPECIFIED:
 DIMENSIONS ARE IN INCHES
 DECIMALS ARE TO 3 PLACES
 FRACTIONS ARE TO 16
 DIMENSIONS TO 30" & OVER
 SHALL BE TO 1/16" TOLERANCE
 DO NOT SCALE DRAWING

DRAWN: RPF
 DATE: 07/03/02
 MATERIAL: N/A
 THE 1/16" ALLOWANCE

© RAILWAY EQUIPMENT CO. 2002-2005
RAILWAY EQUIPMENT CO.
 DELAWARE, MINNESOTA (763) 972-3300

TITLE: TRACK DUCT KIT, 7' LARGE NOZZLE
 PWT NO.: 9278-0270
 SCALE: N/A DRAWING SIZE: B SHEET 1 OF 1

PARTS LIST					
ITEM	PART NUMBER	REV	QTY	UOM	DESCRIPTION
1	14045	-	1	EA	BAG, 12 X 15 4MIL ZIPTOP
2	2600976100	-	2	EA	LAG BOLT, 5/16 X 4, WASHER HEAD, 6 LOBE DRIVE, STEEL, COATED
3	2831551110	-	2	EA	BOLT, 1/4-20 X 5/8 HEX HEAD
4	2832-5901	-	2	EA	NUT, 1/4-20 CENTERLOCK
5	92742B	B	2	EA	SPRING, TRACK DUCT SUPPORT
6	92743	B	2	EA	CLIP, HOLDDOWN SPRING
7	92745	A	1	EA	HOLDDOWN STRAP, T. DUCT
8	927550C	C	1	EA	TRACK DUCT SUPPORT BASE
9	927551	A	1	EA	TRACK DUCT SPRING BRKT NARROW
10	R92774K	-	1	EA	LABEL, TRACK DUCT BRACKET

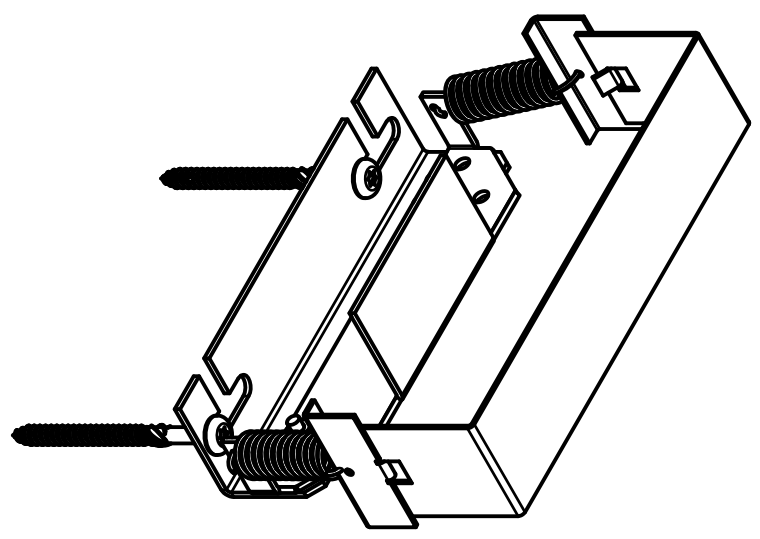
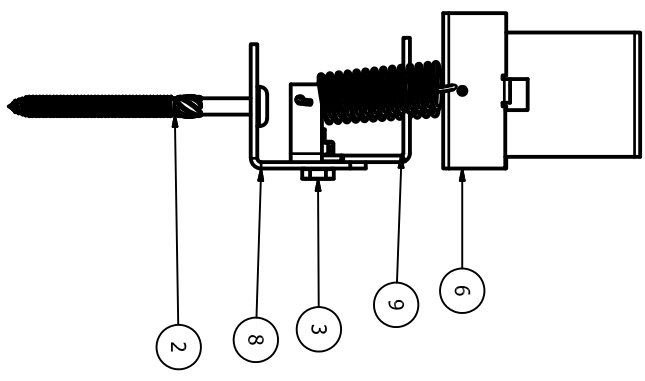
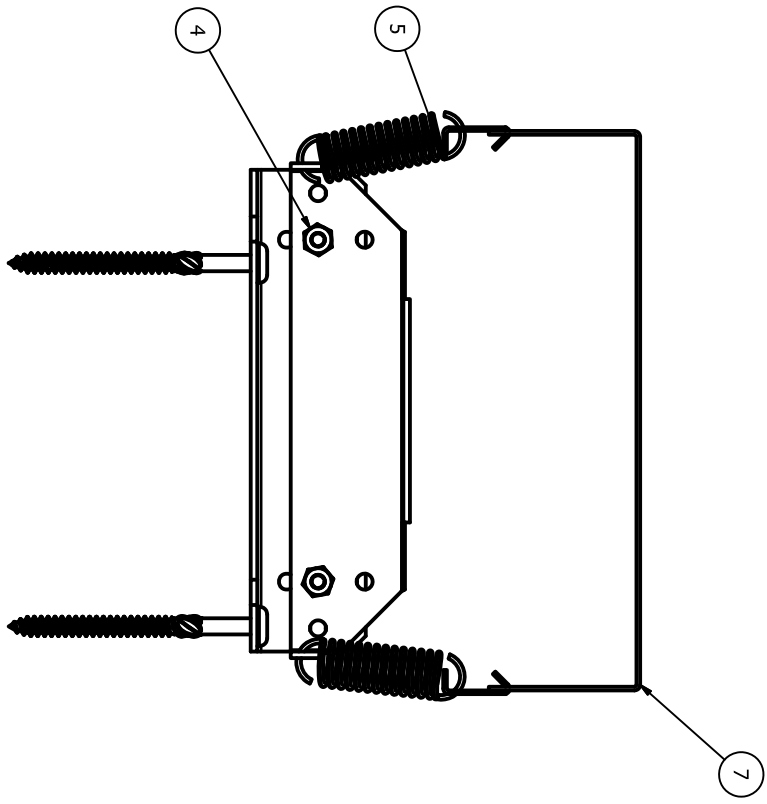

REVISION HISTORY				
REV	ECO #	DESCRIPTION	DATE	BY
J	05-0017	NEW SPLICE SYSTEM	5/18/2005	RF
K	05-0047	SHORTENED 927550-551 PN 9275508 TO C	10/27/2005	RO
-	-	REMOVED PN 14042	1/20/2020	CA
-	-		4/9/2020	CA

RAILWAY EQUIPMENT CO. 2020

RAILWAY EQUIPMENT CO.
 10000 10th Street, NW
 Everett, WA 98203
 (425) 336-4400

UNLESS OTHERWISE SPECIFIED:
 DIMENSIONS ARE IN INCHES
 DECIMALS ANGULAR
 XX .0010 FRACTIONS
 3/16 3/16 FRACTIONS
 3/16 3/16 FRACTIONS
 3/16 3/16 FRACTIONS

DATE: 4/9/2020
 DRAWN BY: gwandersen
 CHECKED BY: NA
 TITLE: TRACK DUCT SUPPORT BRACKET
 PART NO: 92774K
 SCALE: 1/2" = 1" DRAWING: B SHEET: 1 OF 1

REVISION HISTORY

REV	ECO #	DESCRIPTION	DATE	BY
A	-	NEW PART	12/12/2003	RF
B	05-0005	ADDED BULKHEAD TO BLOWER	06/09/2005	IW
C	05-0005	ADD ELBOW/NIPPLE 9528-0027	01/31/2012	MP

OPTIONAL PROPANE KIT
9458-0100
OR
(PROVIDED BY CUSTOMER)

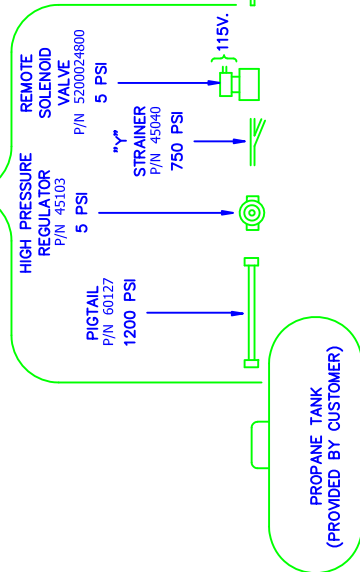

9528-0027
(SHIPPED WITH UNIT)

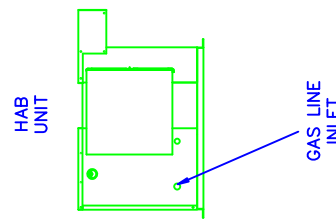
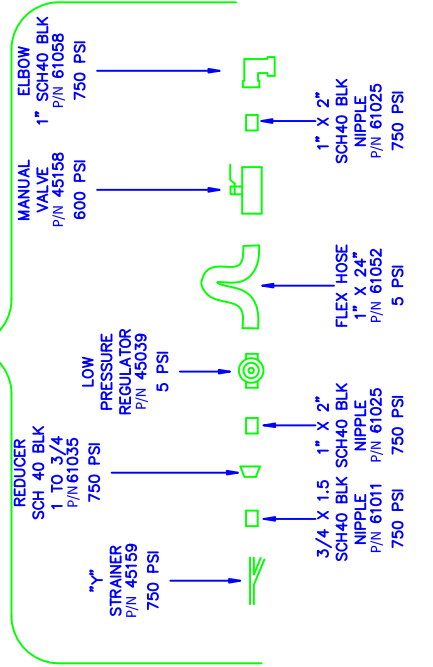

© RAILWAY EQUIPMENT CO. 2020

RAILWAY EQUIPMENT CO.
RAILROAD EQUIPMENT, SUPPLY & SERVICE

UNLESS OTHERWISE SPECIFIED:
DIMENSIONS ARE IN INCHES
DIMENSIONS IN PARENTHESES ARE ANGULAR TOLERANCES
DECIMALS ARE TO NEAREST THOUSANDS
FRACTIONS ARE TO NEAREST SIXTEENTHS
DIMENSIONS ARE TO UNLESS OTHERWISE SPECIFIED
DRAWN TO SCALE
DATE: 2/11/2020
BY: akollman

TITLE: GAS HOT AIR BLOWER, GAS LINE LAYOUT

PROJECT: R9520-0027C
SCALE: 1/8" = 1'-0"
SHEET: 1 OF 1

ITEM	PART NUMBER	REV	UOM	QTY	PARTS LIST	DESCRIPTION
1	14165	-	EA	2	14165	RATCH FOR SCREWS
2	16003	-	EA	.33	16003	RAVIL SILICONE CLEAR 10 OZ TUBE
3	26020A	A	EA	1	26020A	INLET CONE, 1250 90%
4	26027B	B	EA	1	26027B	BLOWER WHEEL ASSY, 3HP, 2
5	26035	-	EA	6	26035	MOUNT RUBBER MAT 1/4-20
6	26045	-	EA	4	26045	BOLT, 3/8 X 2-1/2 HEX LUG
7	26314-9003	-	EA	3	26314-9003	BOLT, 1/4-20 X 1 CARRIAGE
8	2631411108	-	EA	1	2631411108	SCREW, #10-32 X 1/2 PAN SLT
9	2631651110	-	EA	4	2631651110	BOLT, 1/4-20 X 5/8 HEX HEAD
10	2631651112	-	EA	14	2631651112	BOLT, 5/16-18 X 3/4 HEX HEAD
11	2631651116	-	EA	12	2631651116	BOLT, 3/8-16 X 1 HEX CAP
12	2631661112	-	EA	28	2631661112	BOLT, 3/8-16 X 3/4 CARRIAGE
13	2632-4101	-	EA	2	2632-4101	NUT, #1/2-20 HEX
14	2632-5101	-	EA	12	2632-5101	NUT, 1/4-20 HEX
15	2632-5801	-	EA	7	2632-5801	NUT, 1/4-20 CENTERLOCK
16	2632-6801	-	EA	14	2632-6801	NUT, 5/16-18 CENTERLOCK
17	2632-8101	-	EA	18	2632-8101	NUT, 3/8-16 HEX
18	2632-8804	-	EA	32	2632-8804	NUT, 3/8-16 CENTERLOCK
19	2633-4310	-	EA	4	2633-4310	WASHER, #10 EXT STAR
20	2633-5110	-	EA	14	2633-5110	WASHER, 1/4 FLAT
21	2633-5119	-	EA	8	2633-5119	WASHER, 1/4 X 1.5 FENDER
22	2633-5211	-	EA	14	2633-5211	WASHER, 5/16 FLAT SAE
23	2633-6110	-	EA	9	2633-6110	Rivet, BUTT ON HEAD PLATED STL
24	2633-6940	-	EA	4	2633-6940	WASHER, 3/8 X 1-1/2 FENDER
25	2633-8110	-	EA	4	2633-8110	WASHER, 3/8 FLAT
26	2633-8119	-	EA	4	2633-8119	WASHER, 3/8 X 1-1/2 FENDER
27	2633-8210	-	EA	15	2633-8210	WASHER, 3/8 SPRT LOCK
28	26017	-	EA	4	26017	BOLT, #6-32 X 3/8 WASHER HEAD
29	26019	-	EA	12	26019	BOLT, 1/4-20 X 1.3 SHOULDER THREAD ROLLING
30	26061	-	EA	133	26061	BOLT, 1/4-20 X 1/2 WITH 1/2 HD
31	32002	-	SOFT	17	32002	INSULATION, FIBERGLASS
32	32007	-	EA	2	32007	POST, 4 X 4 X 8 TREATED
33	60002	-	EA	1	60002	3/8 ROMEX BRIDGEPORT#1 66002
34	60071	-	EA	1	60071	CONDUIT, FLEX CONNECTOR STRT
35	60076	-	EA	1	60076	CONDUIT, FLEX CLAMPS 3/4 IN
36	60169	-	EA	12	60169	TY-RAP
37	60172	-	EA	1	60172	LUG, RING #10 22-18GA H4 TEMP
38	60185A	A	FT	7	60185A	GASKET, .25X.75 ADHESIVE BACK
39	60195	-	EA	6	60195	GASKET, .25 X 1.0 ADHESIVE BK
40	60247	-	EA	1	60247	KNOCKOUT PLUG, 3/4 INCH
41	6093-0100	-	EA	5	6093-0100	CABLE TIE, 4IN X 1.0 WIDTH
42	6093-0102	-	EA	12	6093-0102	TY-RAP
43	61032	-	EA	1	61032	NIPPLE, 1 X 3 IN SCH 40 BLACK
44	61047	-	EA	1	61047	NIPPLE, 1 X 5 IN SCH 40 BLACK
45	61058	-	EA	1	61058	ELBOW, 1IN SCH 40 BLACK
46	61070	-	EA	1	61070	U-BOLT, MRO BOLT #5
47	681803	-	FT	3	681803	WIRE, 18GA BILDEN HIGH TEMP
48	8040-9955E	E	EA	1	8040-9955E	NAMEPLATE, 994/995 GHAB
49	92919A	A	EA	10	92919A	WASHER, 1/4 EXT. STAR
50	950132B	B	EA	1	950132B	DUCT, FLAME DUCT, SHP W/ SENSOR
51	950210A	A	EA	1	950210A	BRACKET, HAB ENCLOSURE MOUNT-BOTTOM
52	950221A	A	EA	2	950221A	BRACKET, HAB ENCLOSURE MOUNT
53	95047B	B	EA	1	95047B	ENCLOSURE, HAB
54	95056C	C	EA	1	95056C	BRACKET, GAS SUPPORT INSIDE
55	95059A	A	EA	1	95059A	COVER, MUFFLER GHAB
56	95060B	B	EA	1	95060B	COVER PLATE, GAS LINE 6 & 3HP
57	95064-038A	-	EA	1	95064-038A	ASSY, GAS SENSOR EXT CABLE
58	95064-038C	C	EA	1	95064-038C	ASSY, HI TEMP SENSOR CR 15FT THE DUCT MOUNT
59	95064-040A	A	EA	1	95064-040A	AIR TEMPERATURE SENSOR 4" MAGNETIC
60	95064-15B	B	EA	1	95064-15B	RAIL TEMP SNSR 7" MAGNETIC
61	95202A	A	EA	1	95202A	PLATE, MOTOR BASE, 184T GHAB
62	95204B	B	EA	1	95204B	COVER, MOTOR
63	952127C	C	EA	2	952127C	STUD, PLATE

ITEM	PART NUMBER	REV	UOM	QTY	PARTS LIST	DESCRIPTION
64	952138A	A	EA	3	952138A	LIFTING PLATE
65	95221E	E	EA	1	95221E	BASE, GHAB, 3HP
66	95250C	C	EA	1	95250C	INTAKE BODY, 5HP
67	95251B	B	EA	1	95251B	COVER, FRONT INTAKE
68	95254C	C	EA	1	95254C	MOTOR MOUNTING PLATE, HAB
69	95259C	C	EA	1	95259C	INTAKE TOP, HAB, 3HP LOW
70	95259B	B	EA	1	95259B	INTAKE SCREEN, FLIP DOWN 1"
71	95257B	B	EA	1	95257B	DEFLECTOR, INTAKE 3HP LOW GHAB
72	95258A	A	EA	1	95258A	COVER, INTAKE LOW 3S HP
73	952688A	A	EA	1	952688A	BASE, GHAB MOTOR
74	9526-027E	E	EA	1	9526-027E	ASSY, GAS LINE ACCESSORIES 3HP
75	9526-0074D	D	EA	1	9526-0074D	GASKET KIT, 9X9 5HP DUCTWORK
76	9526-0135C	C	EA	1	9526-0135C	BURNER, 22IN STAINLESS STEEL
77	9526-0153A	A	EA	1	9526-0153A	ASSY, 5HP LOW PRO PRESSURE SWITCH PORT AND DUCT SENSOR
78	952810B	B	EA	1	952810B	INSUL COVER, REDUCER WRAP
79	952811A	A	EA	1	952811A	INSUL BASE, REDUCER WRAP
80	952813A	A	EA	1	952813A	COVER, ACCESS 952 BURNER
81	95256A	A	EA	1	95256A	DMP RAIL, HAB WITH LATOES
82	9538-0045C	C	EA	1	9538-0045C	ASSY, FLAME WIRE
83	9538-0048A	A	EA	1	9538-0048A	ASSEMBLY, IGNITION WIRE
84	9538-0051A	A	EA	1	9538-0051A	WIRED IGN XRMER 3HP/5HP/CSA
85	9538-0060A	A	EA	1	9538-0060A	ASSY, WIRED MOTOR, 3HP 230V 3PH
86	9558-0154D	D	EA	1	9558-0154D	ASSY, GHAB CONTROL PANEL, 3HP 230V AC DRIVE
87	9558-0237C	C	EA	1	9558-0237C	GHAB GAS PIPING W/ PRESSURE SENSOR
88	95632B	B	EA	1	95632B	BLOWER, AIR OUT FLANGE 3HP
89	95346A	A	EA	1	95346A	MOTOR MOUNTING PLATE, HAB
90	953800B	B	EA	1	953800B	BLOWER OUTLET FLANGE 5HP
91	953803B	B	EA	1	953803B	BLOWER SHROUD 3HP
92	9509-1051	-	EA	1	9509-1051	RRANAG UPLIFETIME ASSET REGISTRATION FEE
93	R0309-0816A	A	EA	1	R0309-0816A	LABEL, FAN ROTATION
94	R0309-0830A	A	EA	1	R0309-0830A	LABEL, GHAB WARNINGS
95	R0309-0951A	A	EA	1	R0309-0951A	LABEL, GAS CONNECTION/BLK/HEAD
96	R0309-0959B	B	EA	1	R0309-0959B	LABEL, ID PLATE AG/CSA
97	R0560-01001	1	EA	2	R0560-01001	954955 GHAB MANUAL
98	R060031	A	EA	2	R060031	LABEL, HAB ENCLOSURE
99	R09001A	A	EA	1	R09001A	LABEL, CAUTION LABEL INSIDE GHAB ENCLOSURES

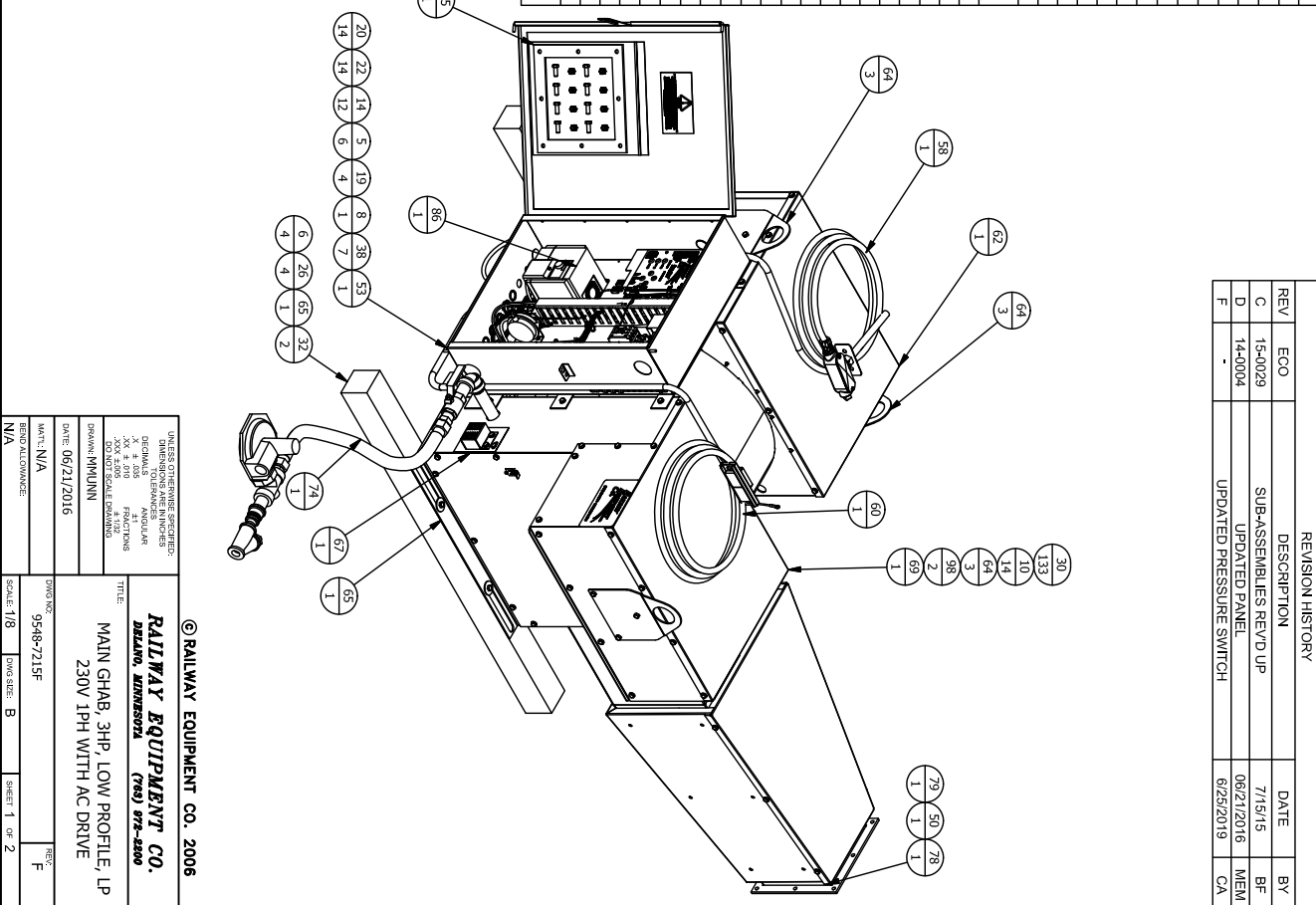

REVISION HISTORY

REV	ECO	DESCRIPTION	DATE	BY
C	15-0029	SUB-ASSEMBLES REV'D UP	7/15/15	BF
D	14-0004	UPDATED PANEL	06/21/2016	MEM
F	-	UPDATED PRESSURE SWITCH	6/25/2019	CA

UNLESS OTHERWISE SPECIFIED:
 DIMENSIONS ARE IN INCHES
 DECIMALS TO 3/16 ANGULAR
 .XX & .010 FRACTIONS
 .XX & .010 FRACTIONS
 .XX & .010 FRACTIONS
 DRAWN: MMUNNI
 DATE: 06/21/2016
 TITLE: MAIN GHAB, 3HP, LOW PROFILE, LP
 Z30V 1PH WITH AC DRIVE
 DWG NO: 9548-7215F
 TEND: ALCORANCE
 SCALE: 1/8" = 1"
 DWG SIZE: B
 SHEET 1 OF 2

RAILWAY EQUIPMENT CO. 2006
DELLA, KIMBERLY (781) 972-4200

UNLESS OTHERWISE SPECIFIED:
 DIMENSIONS ARE IN INCHES
 DECIMALS AND ANGULAR
 DIMENSIONS ARE TO BE
 .XX ± 0.010 FRACTIONS
 TO NEAREST SCALE DRAWING
 DRAWING: MMUNN

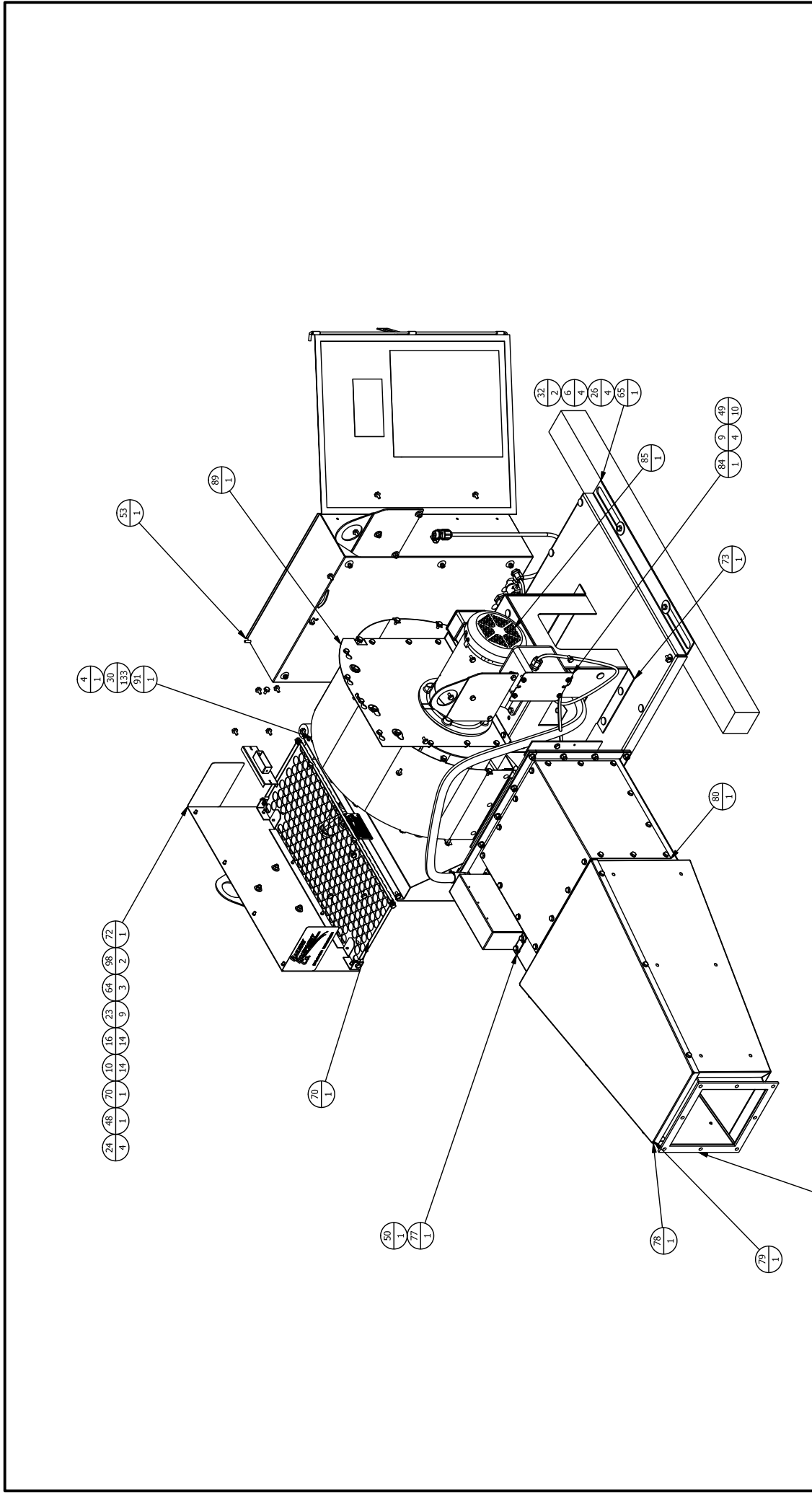

© RAILWAY EQUIPMENT CO. 2006
RAILWAY EQUIPMENT CO.
 DELAWARE, MINNESOTA (763) 872-2800
 TITLE: MAIN GHAB, 3HP, LOW PROFILE, LP
 230V 1PH WITH AC DRIVE
 DATE: 06/21/2016
 DWG NO.: 9548-7215F
 REVISION: F
 SCALE: 1/1
 DRAWING: B SHEET 2 OF 2

ITEM	PART NUMBER	REV	QTY	UOM	DESCRIPTION
1	1300749700	-	1	EA	CIRCUIT BREAKER, 2 POLES 50 AMP 480
2	14046	-	1	EA	VOLT INDUCTIVE
3	14172	-	1	EA	BAG, 9 X 12 4MIL ZIPTOP
4	2100166500	-	1	EA	HEATER, PANEL HEATER 100W 120VAC NO THERMOSTAT 30" LEADS
5	21020	-	1	EA	DRIVE, AC, 3 HP, 240V 1PH INPUT, 240V 3 PH OUTPUT
6	21021	-	1	EA	CONNECTOR, HOUSING, 2 POS
7	21023	-	1	EA	STRAIN RELIEF, 2 POS
8	21212	-	1	EA	CONNECTOR, HOUSING, 3 POS 18GA
9	28029	-	1	EA	TERMINAL ASSY, 1 X 12 POS
10	28077	-	1	EA	GROMMET, .25 I.D., 9/16 O.D BLACK
11	28090	-	1	EA	CAP, TERMINAL POST INSULATING
12	28091	-	1	EA	SHIELD, TERMINAL POST INSULATE
13	28104	-	4.5	EA	DIN MOUNTING RAIL 35MM
14	2831211106	-	1	EA	SCREW, #6-32 X 3/8 PAN SLT
15	2831211116	-	2	EA	SCREW, #6-32 X 1 PAN SLT
16	2831311106	-	5	EA	SCREW, #8-32 X 3/8 PAN SLT
17	2831411106	-	13	EA	SCREW, #10-32 X 3/8 PAN SLT
18	2831411108	-	4	EA	SCREW, #10-32 X 1/2 PAN SLT
19	2831411110	-	3	EA	SCREW, #10-32 X 5/8 PAN SLT
20	2832-4301	-	2	EA	NUT, #10-32 KEPS
21	2832-6301	-	2	EA	NUT, #6-32 KEPS
22	2833-3110	-	4	EA	WASHER, #8 FLAT SAE
23	2833-4210	-	4	EA	WASHER, #10 SPLIT LOCK
24	2833-4310	-	2	EA	WASHER, #10 EXT. STAR
25	29104	-	3	EA	CLAMP, DIN MOUNT END
26	3100104000	-	6	EA	LUG, 18GA MALE FERRULE INSULATED
27	35205A	A	1	EA	BRACKET, PRESSURE SWITCH MOUNT FOR PANEL
28	51274	-	1	EA	FUSE HOLDER, INLINE 18 GA
29	51275	-	1	EA	FUSE, 2A MDA 250V
30	53096	-	1	EA	PRESSURE SWITCH
31	5400489800	-	1	EA	CONTRACTOR, 4POLE 32 AMP 115V COIL 9 AMP INDUCTIVE
32	60167	-	1	EA	FITTING, 900 MALE BRASS
33	60223	-	12	IN	HEATSHRINK, TUBING 3/16 BLACK
34	6032-0111	-	3	EA	LUG, RING #10 16-14GA NYLON
35	6032-0116	-	3	EA	LUG, RING #10 12-10GA VINYL
36	6032-0117	-	1	EA	LUG, RING 1/4 12-10GA VINYL
37	6032-0118	-	3	EA	LUG, RING 1/4 16-14GA VINYL
38	6032-0119	-	1	EA	LUG, RING #10 22-18GA VINYL
39	6032-0120	-	1	EA	LUG, RING 1/4 22-18GA VINYL
40	6032-0123	-	1	EA	LUG, BUTT CONNECTOR 20-18 GA W/HEAT SHRINK SEAL
41	6034-0111	-	1	EA	LUG, PUSH-ON F, 250 22-18GA
42	6090-0102	-	1	EA	CABLE TIE MOUNTS
43	6093-0003	-	19	IN	WIRE DUCT, 1IN W 3IN H
44	6093-0100	-	15	EA	CABLE TIE, 4IN 0.10 WIDTH
45	6093-0302	-	19	IN	WIRE DUCT, COVER 1 IN
46	61090	-	1	EA	MUFELER / FILTER, 1/8" NPT, 7/16" DIA.
47	681001	-	87	IN	WIRE, 10GA BLACK 600V 105C
48	681205	-	21	IN	WIRE, 12 GA, GREEN

ITEM	PART NUMBER	REV	QTY	UOM	DESCRIPTION
49	681601	-	27.5	IN	WIRE, 16GA GREEN - HOOK UP
50	681832	-	62	IN	WIRE, 18GA 300V 105C BLACK
51	681833	-	32	IN	WIRE, 18GA THINWALL WHITE 300V
52	681834	-	12	IN	WIRE, 18GA THINWALL RED 300V
53	7600001200	-	1	EA	ENCLOSURE FOR SCREW TERM LRG SWITCH
54	9338-0015C	-	1	EA	TRANSFORMER, CONTROL MODULE
55	9338-0320P	-	1	EA	CONTROL MODULE, GHAB W / TC / WEB PAGE ENABLE
56	9338-0325B	-	1	EA	SURGE ARRESTOR ASSY, 240V 1PH
57	9508-0001A	-	1	EA	GHAB MODULE TO AAR HARNESS
58	95085D	-	1	EA	PANEL, GHAB CON WITH DISPLAY
59	9538-0029B	-	1	EA	ASSY, AIR FLOW WIRES HIGH IN PANEL
60	R9330-0021B	-	1	EA	LABEL, TERM POST SMO NET

REV	ECO #	DESCRIPTION
A	17-0016	NEW PART
B	18-0034	MODULE, HEATER
C	-	CHANGE AC DRIVE
D	-	CHANGE TO MITSUBISHI DRIVE AND ALLEN BRADLEY BREAKER/CONTRACTOR

REV	DATE	BY
17-0016	12/11/2017	JT
18-0034	12/18/2018	JT
-	3/6/2019	TB
-	11/21/2019	AK

RAILWAY EQUIPMENT CO. 2019
RAILWAY EQUIPMENT CO.
 10000 W. 10th Street, Aurora, CO 80015
 (303) 680-0000

UNLESS OTHERWISE SPECIFIED:
 DIMENSIONS ARE IN INCHES
 DECIMALS = ANGULAR
 .XX = 4 DIGIT FRACTIONS
 .XXX = 3 DIGIT FRACTIONS
 .000 = THIRDS OF AN INCH
 .0000 = THIRDS OF AN INCH

DATE: 11/21/2019
 DRAWN: AKOULMAN
 TITLE: ASSY, GHAB CONTROL PANEL 3HP 230V AC DRIVE
 DWG NO: 9558-0154D
 REV: D
 SCALE: 1/4
 DIMS: B
 SHEET 1 OF 4

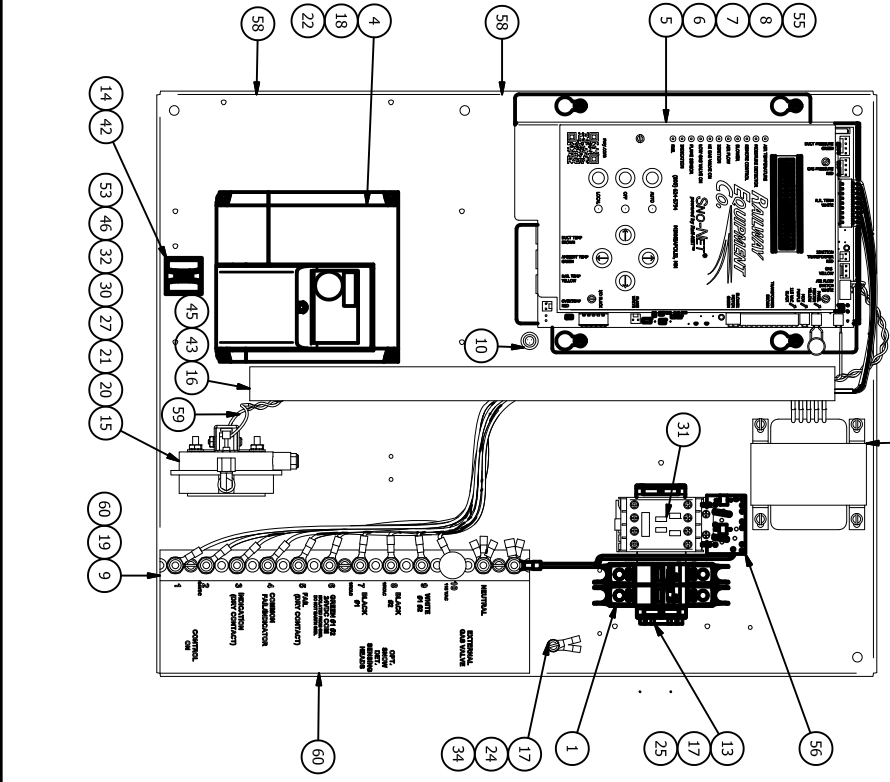

BACK VIEW

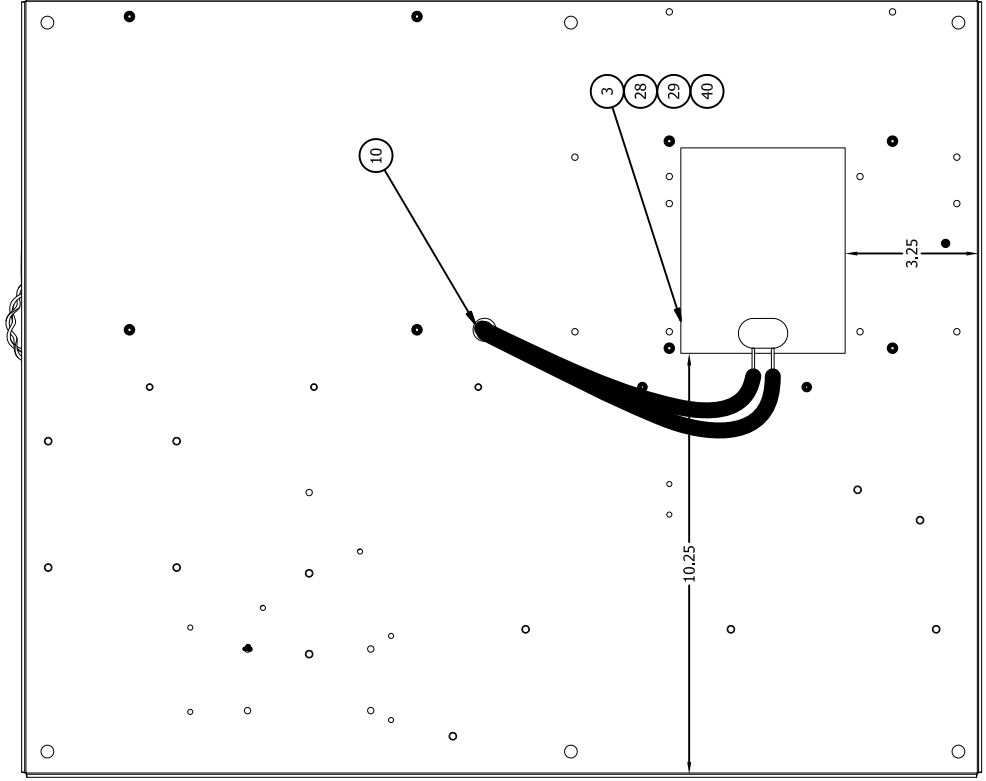

NOTE: PLACE HEATER PAD IN A LOCATION THAT DOES NOT INTERFERE WITH AC DRIVE MOUNTING HOLES

UNLESS OTHERWISE SPECIFIED: DIMENSIONS ARE IN INCHES DECIMALS - ANGULAR FRACTIONS -		© RAILWAY EQUIPMENT CO. 2019	
.XX, 4, 3/16" DO NOT SCALE DRAWING		RAILWAY EQUIPMENT CO. ANN ARBOR, MICHIGAN (734) 662-0800	
DRAWN: AKOLLMAN		TITLE ASSY, GHAB CONTROL PANEL 3HP 230V AC DRIVE	
DATE: 11/21/2019		DWG NO: 9558-0154D	
MTC: N/A		REV: D	
REVISIONS:		SCALE: 1/3	
N/A		DWG SIZE: B	
		SHEET 2 OF 4	

MITSUBISHI DRIVE

NOTE:
 MITSUBISHI DRIVE SETTINGS:
 P1 = 60 MAX HZ
 P2 = 55 MIN HZ
 P3 = 60 MOTOR BASE HZ
 P4 = 60 HZ RUNNING SPEED FOR 2HP AND 3HP, 58HZ FOR 5 HP
 P7 = 20 SECOND RAMP
 P9 = MOTOR OVERLOAD CURRENT 2HP=6, 3HP=8.7, 5HP=13.5
 P77 = 2 CHANGE PARAMETERS WHILE RUNNING
 P79 = 3 EXTERNAL/PU
 P192 = 0 RELAY INDICATION INVERTER RUNNING
 PB72 = 0 FOR 5HP ONLY

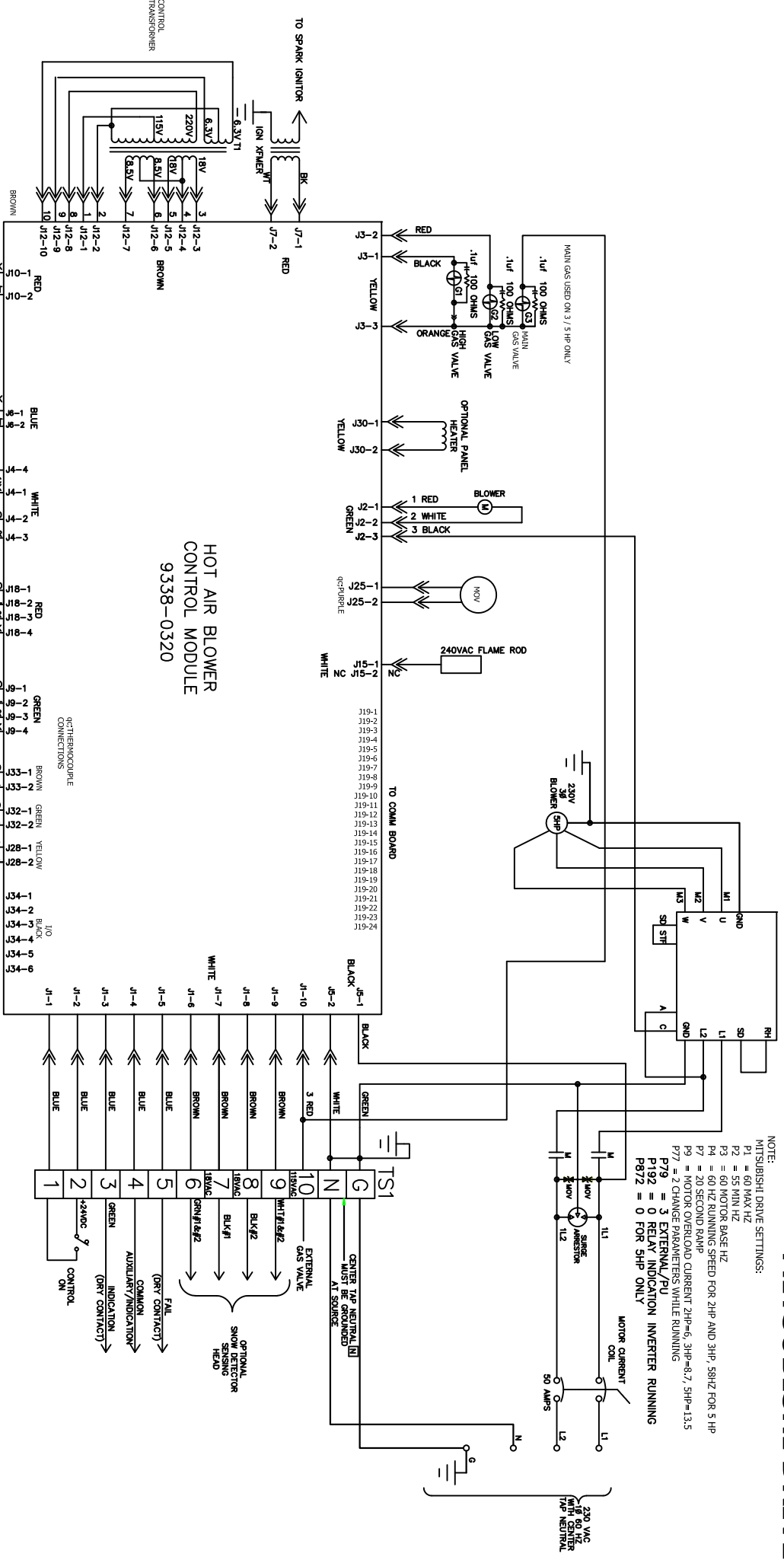

HOT AIR BLOWER CONTROL MODULE 9338-0320

RAILWAY EQUIPMENT CO. 2018
RAILWAY EQUIPMENT CO.
 10000 10th Avenue, North
 Minneapolis, Minnesota 55420 (763) 993-9399

UNLESS OTHERWISE SPECIFIED:
 DIMENSIONS ARE IN INCHES
 DECIMALS ANGULAR
 FRACTIONS
 .000 NOT TO SCALE DRAWING
 DRAWN AKO/MLM
 DATE 11/21/2019
 MITSUBISHI AC DRIVE: 3HP, 240V, 1PH
 SCHEMATIC / CONNECTION DIAGRAM

SCALE: DRAWING: B SHEET 3 OF 4

LENZE DRIVE

NOTE:
LENZE DRIVE SETTINGS:
P100=1
P102=59.9
P106=
P110=3
P140=3

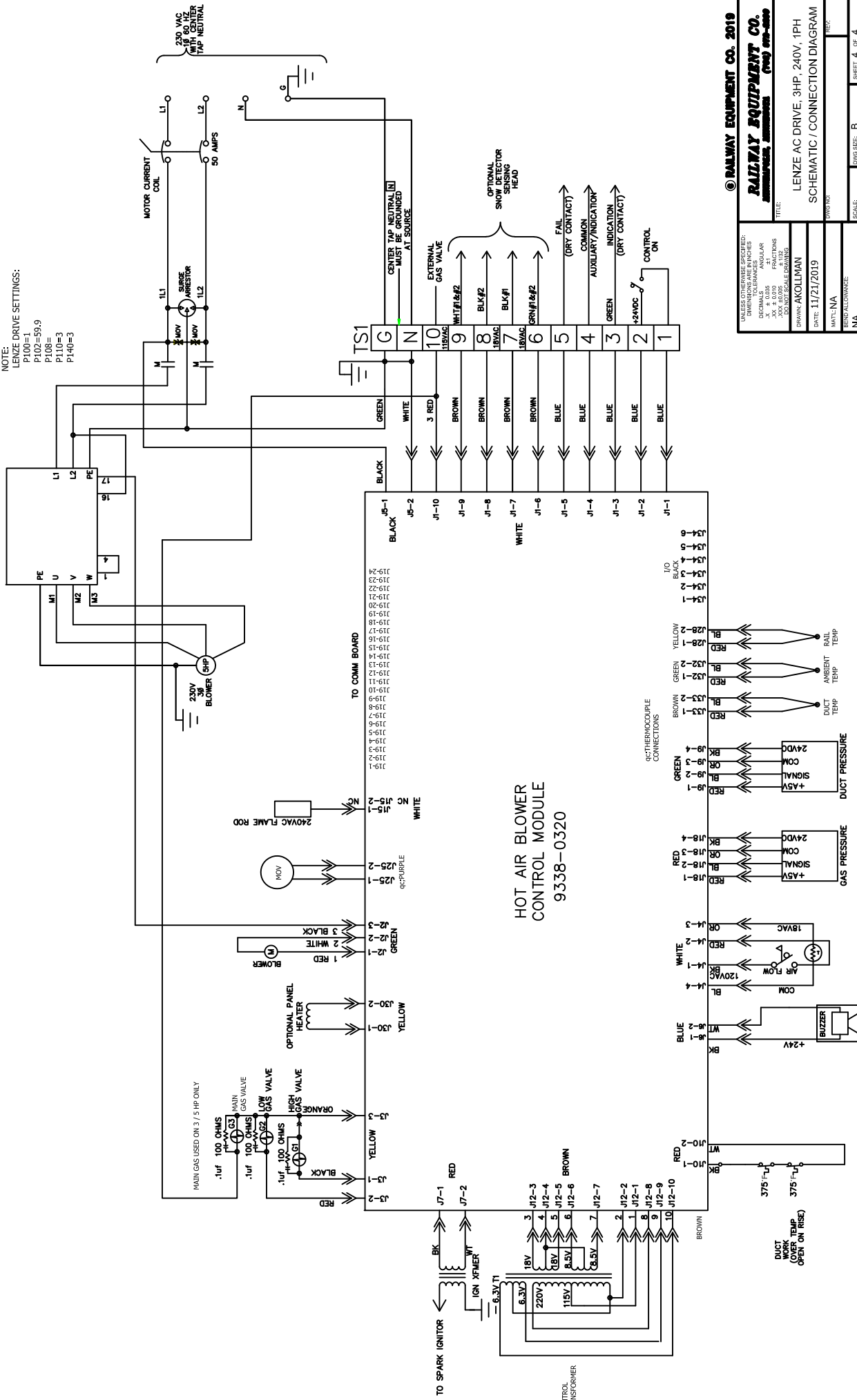

UNLESS OTHERWISE SPECIFIED:
DIMENSIONS ARE IN INCHES
DIMENSIONS IN PARENTHESES
ARE IN MILLIMETERS
DECIMALS TO 3 PLACES
FRACTIONS TO 2 PLACES
DRAWING SCALE: AS SHOWN
MATERIALS: AS SHOWN

RAILWAY EQUIPMENT CO. 2019
RAILWAY EQUIPMENT CO.
1000 W. 10TH ST. SUITE 100
DENVER, CO 80202
(303) 440-0000

TITLE: LENZE AC DRIVE, 3HP, 240V, 1PH
SCHEMATIC / CONNECTION DIAGRAM
DRAWN: AKOLLMAN
DATE: 11/21/2019
REV: NA
SCALE: 1/8"=1'-0"
SHEET 4 OF 4

ITEM	PART NUMBER	REV	UOM	QTY	DESCRIPTION
1	1300748700	EA	1	1	CIRCUIT BREAKER, 2 POLES 50 AMP 480 VOLT INDUCTIVE
2	21020	EA	1	1	CONNECTOR, HOUSING, 2 POS
3	21021	EA	1	1	STRAIN RELIEF, 2 POS
4	21023	EA	1	1	STRAIN RELIEF, 3 POS
5	21212	EA	1	1	CONNECTOR, HOUSING, 3 POS 18GA
6	28029	EA	1	1	TERMINAL ASSY, 1 X 12 POS
7	28090	EA	1	1	CAP, TERMINAL POST INSULATING
8	28091	EA	1	1	SHIELD, TERMINAL POST INSULATE
9	28104	IN	6	6	DIN MOUNTING RAIL 35MM
10	2831211106	EA	2	2	SCREW, #6-32 X 3/8 PAN SLT
11	2831311106	EA	8	8	SCREW, #8-32 X 3/8 PAN SLT
12	2831311108	EA	2	2	SCREW, #8-32 X 1/2 PAN SLT
13	2831411106	EA	11	11	SCREW, #10-32 X 3/8 PAN SLT
14	2831411110	EA	3	3	SCREW, #10-32 X 5/8 PAN SLT
15	2832-4301	EA	2	2	NUT, #6-32 KEPS
16	2832-6301	EA	2	2	NUT, #6-32 KEPS
17	2833-2110	EA	4	4	WASHER, #6 FLAT SAE
18	2833-3110	EA	4	4	WASHER, #8 FLAT SAE
19	2833-4210	EA	4	4	WASHER, #10 SPLIT LOCK
20	2833-4310	EA	4	4	WASHER, #10 EXT. STAR
21	29104	EA	4	4	CLAMP, DIN MOUNT END
22	35209A	EA	1	1	BRACKET, PRESSURE SWITCH MOUNT FOR PANEL
23	53096	EA	1	1	PRESSURE SWITCH
24	5400489800	EA	1	1	CONTACTOR, 4POLE 32 AMP 115V COIL 9 AMP INDUCTIVE
25	5400490300	EA	1	1	OVERLOAD RELAY, 3.2 - 16.0
26	60167	EA	1	1	FITTING, 900 MALE BRASS
27	6031-0102	EA	3	3	LUG, FORK #6-22-18GA NYLON
28	6032-0111	EA	3	3	LUG, RING #10-16-14GA NYLON
29	6032-0116	EA	1	1	LUG, RING #10 12-10GA VINYL
30	6032-0118	EA	6	6	LUG, RING #14 16-14GA VINYL
31	6032-0120	EA	1	1	LUG, RING 1/4 22-18GA VINYL
32	6034-0111	EA	1	1	LUG, PUSH-ON F 250 22-18GA
33	6090-0102	EA	1	1	CABLE TIE MOUNTS
34	6093-0003	IN	15	15	WIRE DUCT, 1IN W 3IN H
35	6093-0100	EA	15	15	CABLE TIE, 4IN 0.10 WIDTH
36	6093-0302	IN	15	15	WIRE DUCT, COVER
37	61090	EA	1	1	WUFLEER / FILTER, 1/8" NPT, 7/16" DIA.
38	681001	IN	56	56	WIRE, 10GA BLACK 600V 105C
39	681601	IN	27.5	27.5	WIRE, 16GA GREEN -HOOK LP
40	681831	IN	67	67	WIRE, 18GA 600V THINWALL BLACK
41	681833	IN	39	39	WIRE, 18 GA THINWALL WHITE 300V
42	681834	IN	29	29	WIRE, 18GA THINWALL RED 300V
43	7600001200	EA	1	1	ENCLOSURE FOR SCREW TERM LRG SWITCH
44	9338-0015C	C	EA	1	TRANSFORMER, CONTROL MODULE
45	9338-0320P	P	EA	1	CONTROL MODULE, GHAB W/ T/C /WEB PAGE ENABLE
46	9338-0326	B	EA	1	SURGE ARRESTOR ASSY, 600V 3PH
47	95075E	E	EA	1	PANEL, GHAB CON WITH DISPLAY
48	9508-0001A	A	EA	1	GHAB MODULE TO AAR HARNESS
49	9508-00037	A	EA	1	ASSY, CURRENT COIL, 100A AC
50	9538-0029B	B	EA	1	ASSY, AIR FLOW WIRES HIGH IN PANEL
51	R9330-Q021B	B	EA	1	LABEL, TERM POST SMD NET

Parts List

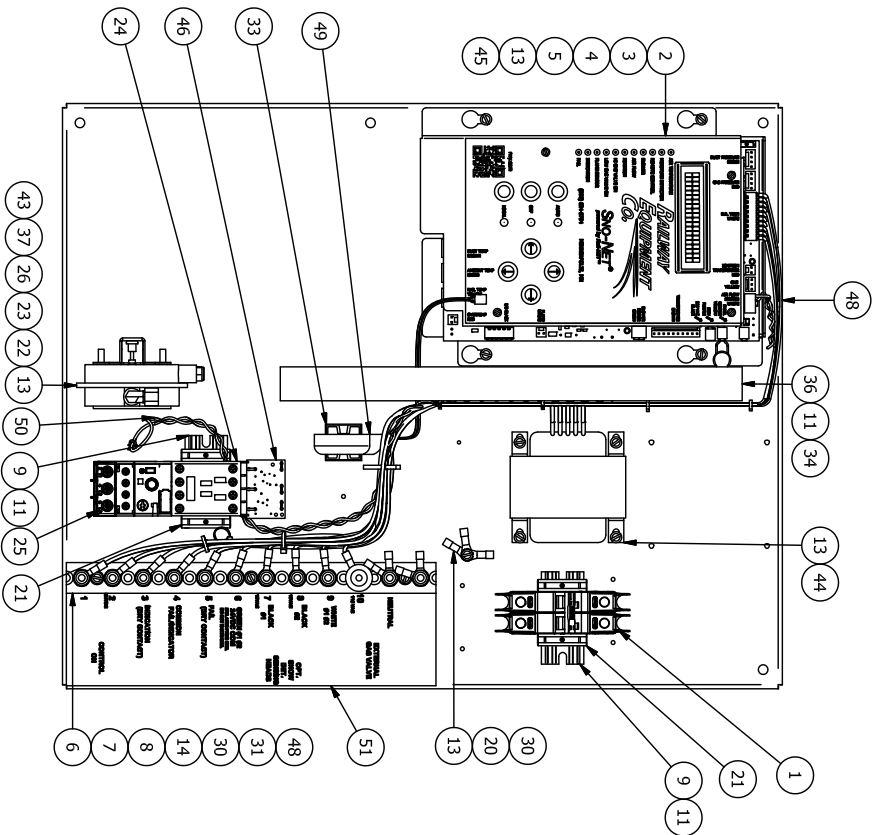

REVISION HISTORY			
REV	ECO #	DESCRIPTION	DATE
A	11-0025	NEW PART	3/4/11
B	11-0014	NEW MODULE	07/07/11
D	14-0014	NEW CONTACTOR AND BREAKER	06/03/2016
E	--	CONTACTOR/OU/CB TO ALLEN BRADLEY, ADDED PRESSURE SENSOR	11/12/2019

© RAILWAY EQUIPMENT CO. 2019

RAILWAY EQUIPMENT CO.
 DELANO, MINNESOTA (763) 875-8500

UNLESS OTHERWISE SPECIFIED:
 DIMENSIONS ARE IN INCHES
 DECIMALS ANGULAR
 XX, 4 0.010 FRACTIONS
 XX, 0.0015 INCHES
 XX, 0.0015 INCHES
 DRAWN: CA
 DATE: 5/17/2019
 WRT: SEE B.O.M.
 TENG: ALCORINCE
 N/A

TITLE: GHAB CONTROL 3PH 1PH 230V WITH DISPLAY

DWG NO: 9538-0150E
 SCALE: DIMS: SEE B SCALE: 1" = 1"

REV: E
 SHEET 1 OF 1

REV	ECO #	DESCRIPTION	DATE	BY
H	14-0004	NEW CONTACT/OVERLOAD/BRKR	05/31/16	MEM
J	-	ADD PRESSURE SWITCH	5/16/19	CA
K	-	UPDATE CONTACTOR/CB/OL TO ALLEN BRADLEY	11/12/2019	AK

REV	UOM	QTY	DESCRIPTION
EA	1	1	BAG, 9 X 12 4MIL ZIPTOP
EA	1	1	CONNECTOR, HOUSING, 2 POS
EA	1	1	STRAIN RELIEF, 2 POS
EA	1	1	STRAIN RELIEF, 3 POS
EA	1	1	CONNECTOR, HOUSING, 3 POS 18GA
EA	1	1	TERMINAL ASSY, 1 X 12 POS
EA	1	1	CAP, TERMINAL POST INSULATING
EA	1	1	SHIELD, TERMINAL POST INSULATE
IN	3	3	DIN MOUNTING RAIL 35MM
EA	6	6	SCREW, #6-32 X 3/8 PAN SLT
EA	2	2	SCREW, #6-32 X 1 PAN SLT
EA	9	9	SCREW, #8-32 X 3/8 PAN SLT
EA	2	2	SCREW, #8-32 X 1/2 PAN SLT
EA	13	13	SCREW, #10-32 X 3/8 PAN SLT
EA	4	4	SCREW, #10-32 X 1/2 PAN SLT
EA	3	3	SCREW, #10-32 X 5/8 PAN SLT
EA	2	2	NUT, #10-32 KEPS
EA	2	2	NUT, #6-32 KEPS
EA	4	4	WASHER, #8 FLAT SAE
EA	2	2	WASHER, #8 SPLIT LOCK
EA	8	8	WASHER, #10 SPLIT LOCK
EA	2	2	WASHER, #10 EXT. STAR
EA	2	2	CLAMP, DIN MOUNT END
EA	2	2	FUSE, 500V 1AMP SLO-BLO
EA	1	1	CIR BRKR, 15A 600V 3 POLE
EA	1	1	FUSEBLOCK, 600V 30A 2 POLE
EA	2	2	FUSEBLOCK COVER 600V 30A
EA	1	1	PRESSURE SWITCH
EA	1	1	CONTACTOR, 4POLE 32 AMP 115V COIL 9 AMP INDUCTIVE
EA	1	1	OVERLOAD RELAY, 3.2 - 16.0
EA	1	1	TRANS, 575 MAX P-115S 300VA
EA	1	1	FITTING, 900 MALE BRASS
EA	1	1	LUG, FORK #6-16GA NYLON
EA	3	3	LUG, FORK #6-22-18GA NYLON
EA	3	3	LUG, RING #10-16-14GA NYLON
EA	5	5	LUG, RING 1/4 16-14GA VINYL
EA	1	1	LUG, RING 1/4 22-18GA VINYL
EA	1	1	WIRE DUCT, 1IN W 3IN H
EA	15	15	CABLE TIE, 4IN 0.10 WIDTH
EA	19	19	WIRE DUCT, COVER 1 IN
EA	1	1	MUFFLER / FILTER, 1/8" NPT, 7/16" DIA.
EA	42	42	WIRE, 10GA BLACK 600V 105C
EA	19	19	WIRE, 16GA GREEN - HOOK UP
EA	49	49	WIRE, 18 GA THINWALL WHITE 300V
EA	19	19	WIRE, 18GA THINWALL RED 300V
EA	1	1	ENCLOSURE FOR SCREW TERM LRG SWITCH
EA	1	1	TRANSFORMER, CONTROL MODULE
EA	1	1	CONTROL MODULE, GHAB W / TC / WEB PAGE ENABLE
EA	1	1	SURGE ARRESTOR ASSY, 600V 3PH
EA	1	1	GHAB MODULE TO AAR HARNESS
EA	1	1	FINGER SAFE COVER FOR 51200
EA	1	1	PANEL, GHAB CON WITH DISPLAY
EA	1	1	ASSY, AIR FLOW WIRES HIGH IN PANEL
EA	1	1	LABEL, TERM POST SNO NET

ITEM	PART NUMBER	REV	UOM	QTY	DESCRIPTION
1	14046	-	EA	1	BAG, 9 X 12 4MIL ZIPTOP
2	21020	-	EA	1	CONNECTOR, HOUSING, 2 POS
3	21021	-	EA	1	STRAIN RELIEF, 2 POS
4	21023	-	EA	1	STRAIN RELIEF, 3 POS
5	21212	-	EA	1	CONNECTOR, HOUSING, 3 POS 18GA
6	28029	-	EA	1	TERMINAL ASSY, 1 X 12 POS
7	28090	-	EA	1	CAP, TERMINAL POST INSULATING
8	28091	-	EA	1	SHIELD, TERMINAL POST INSULATE
9	28104	-	IN	3	DIN MOUNTING RAIL 35MM
10	2831211106	-	EA	6	SCREW, #6-32 X 3/8 PAN SLT
11	2831211116	-	EA	2	SCREW, #6-32 X 1 PAN SLT
12	2831311106	-	EA	9	SCREW, #8-32 X 3/8 PAN SLT
13	2831311108	-	EA	2	SCREW, #8-32 X 1/2 PAN SLT
14	2831411106	-	EA	13	SCREW, #10-32 X 3/8 PAN SLT
15	2831411108	-	EA	4	SCREW, #10-32 X 1/2 PAN SLT
16	2831411110	-	EA	3	SCREW, #10-32 X 5/8 PAN SLT
17	2832-4301	-	EA	2	NUT, #10-32 KEPS
18	2832-6301	-	EA	2	NUT, #6-32 KEPS
19	2833-3110	-	EA	4	WASHER, #8 FLAT SAE
20	2833-3200	-	EA	2	WASHER, #8 SPLIT LOCK
21	2833-4210	-	EA	8	WASHER, #10 SPLIT LOCK
22	2833-4310	-	EA	2	WASHER, #10 EXT. STAR
23	29104	-	EA	2	CLAMP, DIN MOUNT END
24	35205A	-	A	2	BRACKET, PRESSURE SWITCH MOUNT FOR PANEL
25	5111-0601	-	EA	2	FUSE, 500V 1AMP SLO-BLO
26	51200	-	EA	1	CIR BRKR, 15A 600V 3 POLE
27	5122-0400	-	EA	1	FUSEBLOCK, 600V 30A 2 POLE
28	5122-0401	-	EA	2	FUSEBLOCK COVER 600V 30A
29	53096	-	EA	1	PRESSURE SWITCH
30	5400489800	-	EA	1	CONTACTOR, 4POLE 32 AMP 115V COIL 9 AMP INDUCTIVE
31	5400490300	-	EA	1	OVERLOAD RELAY, 3.2 - 16.0
32	56058	-	EA	1	TRANS, 575 MAX P-115S 300VA
33	60167	-	EA	1	FITTING, 900 MALE BRASS
34	6031-0101	-	EA	1	LUG, FORK #6-16GA NYLON
35	6031-0102	-	EA	3	LUG, FORK #6-22-18GA NYLON
36	6032-0111	-	EA	3	LUG, RING #10-16-14GA NYLON
37	6032-0118	-	EA	5	LUG, RING 1/4 16-14GA VINYL
38	6032-0120	-	EA	1	LUG, RING 1/4 22-18GA VINYL
39	6093-0003	-	EA	19	WIRE DUCT, 1IN W 3IN H
40	6093-0100	-	EA	15	CABLE TIE, 4IN 0.10 WIDTH
41	6093-0302	-	EA	19	WIRE DUCT, COVER 1 IN
42	61090	-	EA	1	MUFFLER / FILTER, 1/8" NPT, 7/16" DIA.
43	681001	-	EA	42	WIRE, 10GA BLACK 600V 105C
44	681601	-	EA	19	WIRE, 16GA GREEN - HOOK UP
45	681831	-	EA	49	WIRE, 18GA 600V THINWALL BLACK
46	681833	-	EA	49	WIRE, 18 GA THINWALL WHITE 300V
47	681834	-	EA	19	WIRE, 18GA THINWALL RED 300V
48	7600001200	-	EA	1	ENCLOSURE FOR SCREW TERM LRG SWITCH
49	9338-0015C	-	EA	1	TRANSFORMER, CONTROL MODULE
50	9338-0320P	-	EA	1	CONTROL MODULE, GHAB W / TC / WEB PAGE ENABLE
51	9338-0326B	-	EA	1	SURGE ARRESTOR ASSY, 600V 3PH
52	9508-0001A	-	EA	1	GHAB MODULE TO AAR HARNESS
53	95080110B	-	EA	1	FINGER SAFE COVER FOR 51200
54	95085D	-	EA	1	PANEL, GHAB CON WITH DISPLAY
55	9538-0029B	-	EA	1	ASSY, AIR FLOW WIRES HIGH IN PANEL
56	R9330-0021B	-	EA	1	LABEL, TERM POST SNO NET

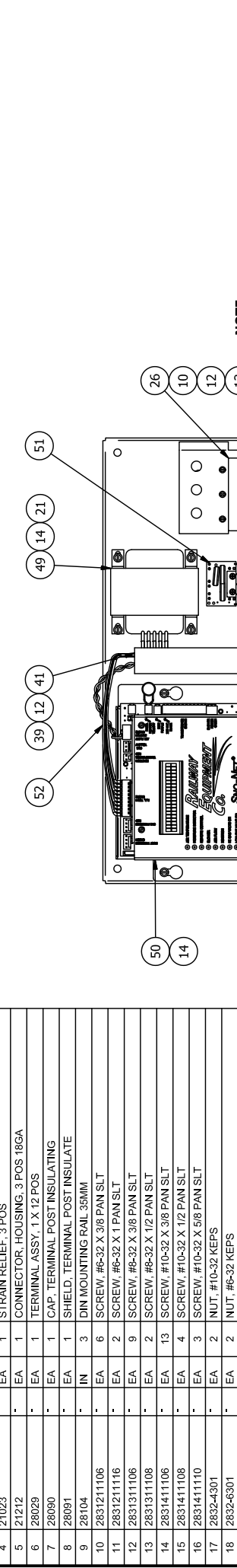

REVISION HISTORY

REV	ECO #	DESCRIPTION	DATE	BY
H	14-0004	NEW CONTACT/OVERLOAD/BRKR	05/31/16	MEM
J	-	ADD PRESSURE SWITCH	5/16/19	CA
K	-	UPDATE CONTACTOR/CB/OL TO ALLEN BRADLEY	11/12/2019	AK

UNLESS OTHERWISE SPECIFIED:
 DIMENSIONS ARE IN INCHES
 DECIMALS - THIRDS
 FRACTIONS - SIXTEENTHS
 DIMENSIONS TO FACE UNLESS OTHERWISE SPECIFIED
 DIMENSIONS TO CENTER UNLESS OTHERWISE SPECIFIED
 DIMENSIONS TO HOLE UNLESS OTHERWISE SPECIFIED

DATE: 5/17/2019
 MFG: SEE B.O.M.
 REV: ALLOWANCE
 SCALE: N/A

© RAILWAY EQUIPMENT CO. 2019
RAILWAY EQUIPMENT CO.
 DELAWARE, MICHIGAN (768) 978-8800

TITLE: ASSY, GHAB CONTROL 3PH AND 5HP 575V 3PH
 DRAWING: CA
 DWG NO: 9528-0224K
 SHEET: B
 SHEET 1 OF 2

NOTE: WHEN THE MAIN HOT AIR BLOWER UNIT IS STARTED FOR THE FIRST TIME, VERIFY THAT THE MOTOR IS TURNING IN THE CORRECT DIRECTION. TO DO THIS, REMOVE THE BOTTOM AIR INTAKE COVER AND CHECK TO SEE IF THE FAN IS ROTATING IN THE CCW DIRECTION. THERE WILL BE AN ARROW SHOWING THE CORRECT ROTATION DIRECTION. IF THE FAN IS NOT ROTATING IN THE CORRECT DIRECTION, SWAP 2 OF THE INPUT WIRES.

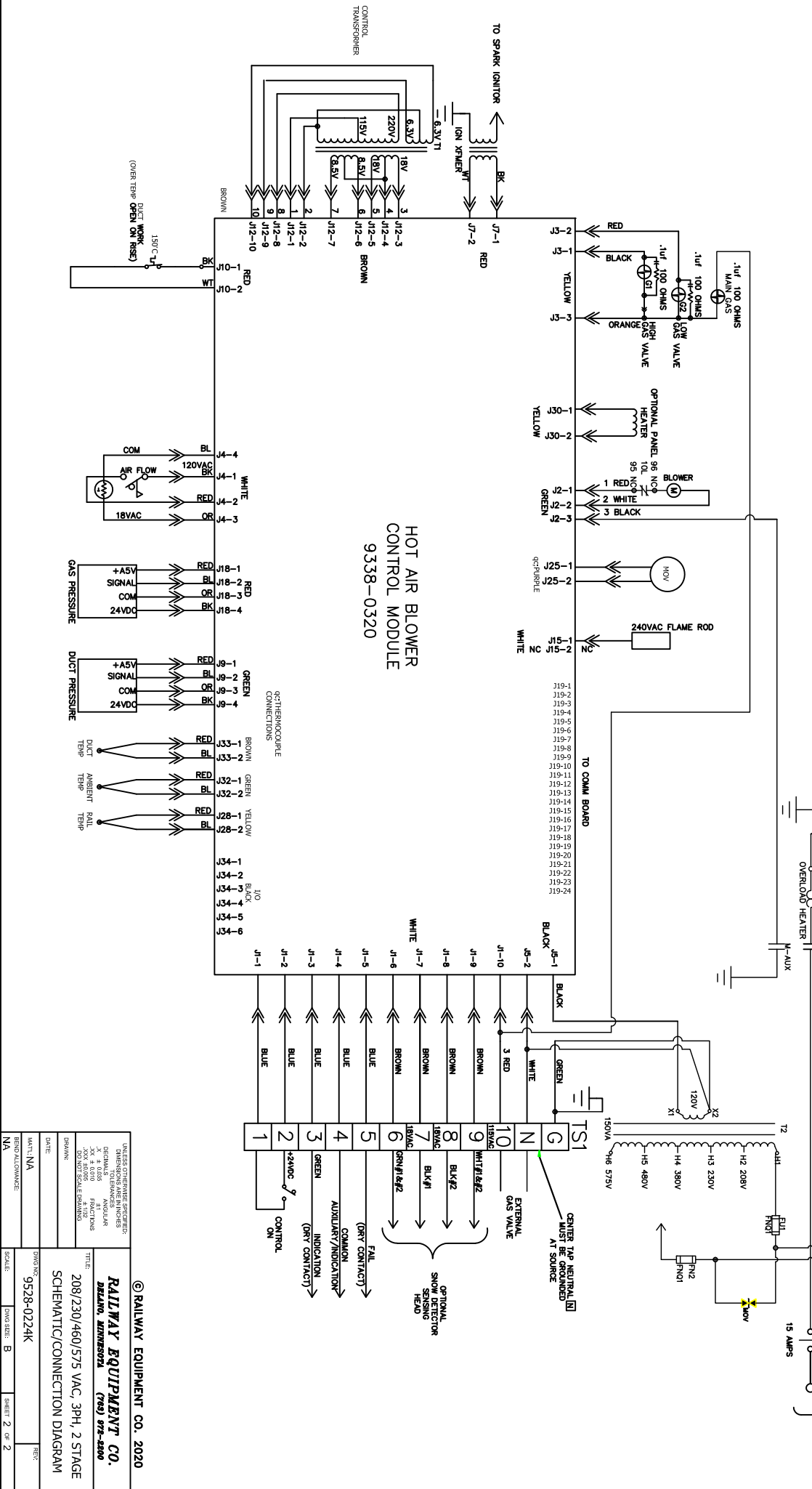

HOT AIR BLOWER CONTROL MODULE
9338-0320

© RAILWAY EQUIPMENT CO. 2020

RAILWAY EQUIPMENT CO.
DELAWARE, MINNESOTA (763) 972-4300

UNLESS OTHERWISE SPECIFIED:
DIMENSIONS ARE IN INCHES
DECIMALS ANGULAR
X.X 4 0/10
FRACTIONS
30 AND 16 ARE IN DENOMINATOR

TITLE: 208/230/460/575 VAC, 3PH, 2 STAGE SCHEMATIC/CONNECTION DIAGRAM

DATE: 9528-0224K

DRAWN: WAT/NA

DESIGNED: WAT/NA

SCALE: 1/1

TENS: 2 OF 2

ITEM	PART NUMBER	REV	UOM	QTY	DESCRIPTION
1	21023	-	EA	1	STRAIN RELIEF, 3 POS
2	21212	-	EA	1	CONNECTOR, HOUSING, 3 POS 18GA
3	2831551134	-	EA	8	BOLT, 1/4-20 X 1-3/4 HEXTAP SS
4	2831551410	-	EA	2	BOLT, 1/4-20 X 5/8 HEX HEAD SS
5	2833-5115	-	EA	10	WASHER, 1/4 FLAT SS
6	2833-5241	-	EA	10	WASHER, 1/4 SPLIT LOCK SS
7	4100151800	-	EA	1	NIPPLE, 1/4"X4.5" SCH 80
8	4100153000	-	EA	1	NIPPLE, BLACK 1" X 7" SCH 40
9	45035	-	EA	1	VALVE, K3A552, 0-3PSI GAS
10	45155	-	EA	2	VALVE, COMBUSTION
11	60002	-	EA	5	3/8 ROMEX BRIDGEPORT# 650-DC2
12	60011	-	EA	1	CONNECTOR, CORD 1/2INCH STRT
13	60160	-	EA	1	CONDUIT, LOCK NUT 1/2 IN
14	60197	-	EA	1	FLEX HOSE 3/4 X 18 - .58 OD
15	60226	-	EA	1	TEE, 1 X 1 X 3/4 SCH 40
16	60231	-	EA	4	O-RING, BUNA-N, 3/16 WIDE
17	60234	-	EA	1	TEE, 3/4 X 3/4 X 1/4 SCH 40 BLK
18	60241	-	IN	110	CABLE, 4 COND, 18GA PVC
19	6032-0120	-	EA	1	LUG, RING 1/4 22-18GA VINYL
20	6092-0201	-	EA	9	LUG, WIRE JOINT NYLON
21	6093-0100	-	EA	2	TY-RAP, 4IN 0.10 WIDTH
22	61011	-	EA	1	NIPPLE, 3/4 X 1.5 SCH 40 BLACK
23	61012	-	EA	1	NIPPLE, 3/4 X 2 SCH 40 BLACK
24	61013	-	EA	1	NIPPLE, 3/4 X 3 SCH 40 BLACK
25	61023	-	EA	1	NIPPLE, 1 X 6 IN SCH 40 BLACK
26	61025	-	EA	1	NIPPLE, 1 X 2 IN SCH 40 BLACK
27	61027	-	EA	1	CAP, PIPE 1 IN SCH 40 BLACK
28	61067	-	EA	1	NIPPLE, 1 X 3.5 IN SCH 40 BLACK
29	61072	-	EA	1	COUPLING, 1/4IN SCH 80
30	681820	-	FT	1	CORD, STRAIGHT 18/2 SJTOW
31	933612D	D	EA	1	COUPLING PLATE 3/4 NPT
32	9336-0043A	A	EA	3	SNUBBER ASSEMBLY, GAS VALVE
33	9338-0070C	C	EA	1	ASSY, GAS PRESSURE SENSOR
34	953811A	A	EA	1	OUTLET MANIFOLD, GASLINE 3/5HP
35	953812A	A	EA	1	COUPLING PLATE 1 INCH NPT
36	955290D	D	EA	1	UNIVERSAL ORIFICE PLATE 3HP

GAS VALVE WIRING DIAGRAM

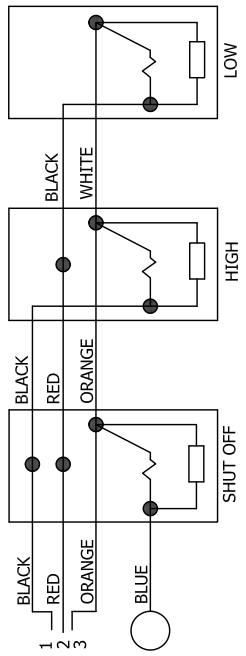

REV	ECO	DESCRIPTION	DATE	BY
A	07-0003	NEW PART	2/8/2007	RMJ
B	07-0016	CHANGE CONDUIT TO CORD	6/6/07	RMJ
C	07-0024	UPDATED TO U-BOLT	8/10/07	WS

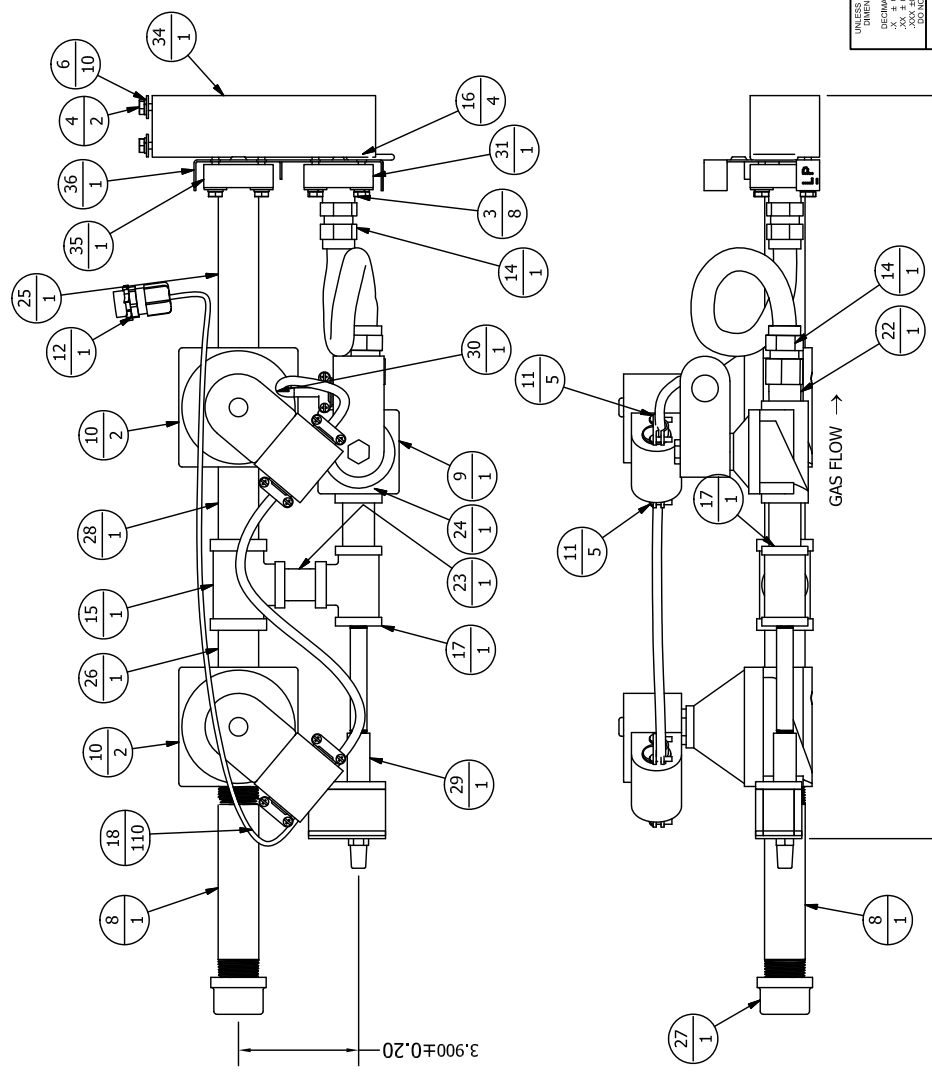

- NOTE:
- USE LOTCITE 401 SEALANT TO INSTALL THE FOUR O-RINGS INTO THE OUTLET MANIFOLD AND THE COUPLING PLATES. DO NOT USE LOTCITE BETWEEN THE O-RINGS AND THE ORIFICE PLATE.
 - WATCH THE GAS FLOW DIRECTION WHEN INSTALLING THE GAS VALVES.

UNLESS OTHERWISE SPECIFIED:
 DIMENSIONS ARE IN INCHES
 DECIMALS - ANGULAR
 FRACTIONS - .XX ± 0.02
 .XXX ± 0.005
 .XXX ± 0.001 SCALE DRAWINGS
 DRAWN: RMJ

© RAILWAY EQUIPMENT CO. 2006

RAILWAY EQUIPMENT CO.
 DELAWARE, MISSISSIPPI (768) 872-5800

THAB GAS PIPING W/ PRESSURE SENSOR
 3HP HIGH PROFILE

DATE: 02/08/07
 DWG NO: 9558-0237C
 SCALE: 1/4" = 1"

REV: C
 SHEET 1 OF 1

PARTS LIST					
ITEM	PART NUMBER	REV	QTY	UOM	DESCRIPTION
1	14500	-	1	EA	MAGNET, CIRCULAR SHIELDED
2	16003	-	0.1	OZ	RTV SILICONE CLEAR 10 OZ TUBE
3	2831311106	-	1	EA	SCREW, #8-32 X 3/8 PAN SLT
4	2832-3103	-	1	EA	NUT, #8-32 SHORT NYLON LOCKNUT
5	2833-3110	-	1	EA	WASHER, #8 FLAT SAE
6	31217	-	1	EA	CONNECTOR, HOUSIN THERMOCOUPLE
7	60051	-	2	EA	CONNECTOR, CORD 1/2 INCH STRT
8	60160	-	2	EA	CONDUIT, LOCK NUT 1/2 IN
9	60203	-	1.25	IN	HEATSHRINK, TUBING HIGH TEMP
10	60275	-	5	FT	CONDUIT, 10MM OD HIGH TEMP
11	681844	-	82	IN	WIRE, THERMOCOUPLE TYPE T 500F PFA
12	9000-0404A	A	1	EA	AMBIENT TEMP SENSOR BRACKET
13	R9508-0404A	A	1	EA	LABEL, AIR TEMP SENSOR MAGNETIC

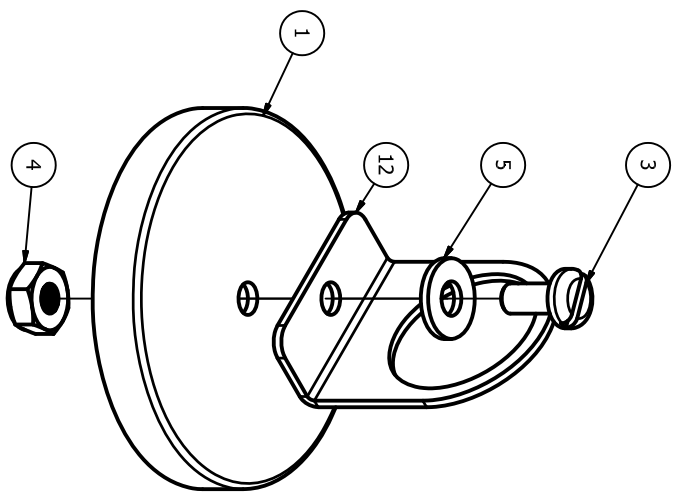

REVISION HISTORY				
REV	ECO #	DESCRIPTION	DATE	BY
A	-	NEW PART	4/5/2016	BF
-	-	ADDED PLASTIC CONNECTOR	12/20/2018	JRG

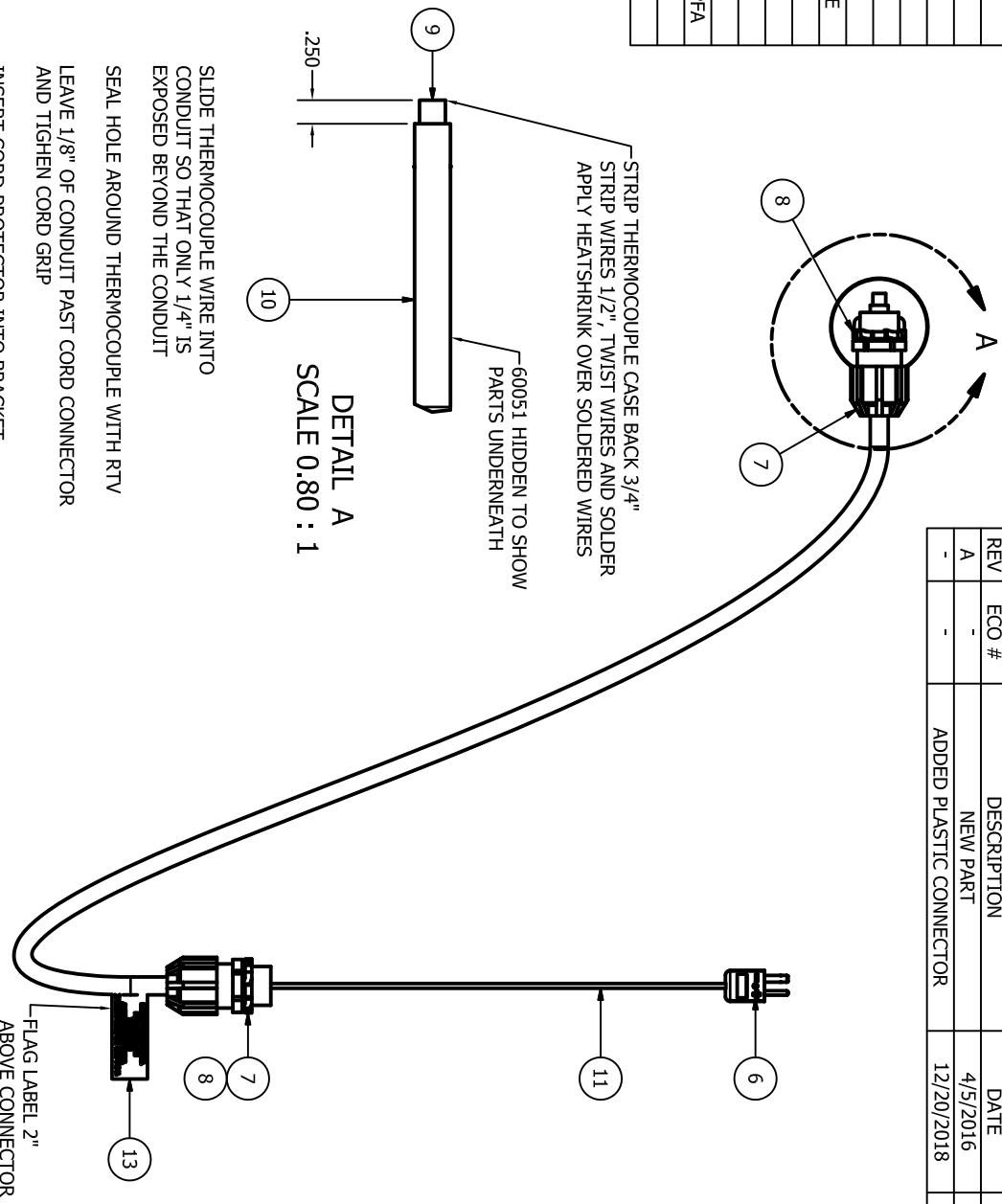

© RAILWAY EQUIPMENT CO. 2018

RAILWAY EQUIPMENT CO.
RAILWAY EQUIPMENT CO. (P) 800-450-0000

UNLESS OTHERWISE SPECIFIED:
DIMENSIONS ARE IN INCHES
DECIMALS ANGULAR
XX 3.016" FRACTIONS
XX 30.480" SCALE DRAWINGS

DATE: 1/2/2020
BY: akollman

ITEM: AIR TEMPERATURE SENSOR 5' MAGNETIC
DRAWING NO: 9508-0404A
SCALE: 2/5
SHEET 1 OF 1

REV	ECO #	DESCRIPTION	DATE	BY
A	-	NEW PART	7/20/04	RF
B	02-0024	NEW BURNER	7/20/04	RJ
C	18-0013	BURNER MATERIAL SS CHANGE	1/10/19	JRG

ITEM	PART NUMBER	REV	QTY	UOM	DESCRIPTION
1	2600949101	-	1	EA	SCREW, 10-32 X 1/2, HEX, SS
2	2831851112	-	4	EA	BOLT, 3/8-16 X 3/4 HEX HEAD
3	2832-4201	-	1	EA	NUT, #10-32 HEX SS
4	2832-8904	-	4	EA	NUT, 3/8-16 CENTERLOCK
5	2833-4310	-	1	EA	WASHER, #10 EXT. STAR
6	3000022400	-	1	EA	SPARK IGNITER, NGK 5464
7	3100115100	-	1	EA	LUG, PUSH-ON F, .250 14-16GA NON INSUL.
8	53070	-	1	EA	FLAME SENSOR, 7.5 INCH
9	6032-0118	-	1	EA	LUG, RING 1/4 16-14GA VINYL
10	61026	-	1	EA	NIPPLE, 1 X 4 IN SCH 40 BLACK
11	61028	-	1	EA	UNION, 1 IN SCH 40 BLACK
12	681402	-	3.5	FT	WIRE, 14GA HIGH TEMP
13	706894	-	1	EA	TERM, TAB, #10
14	952103	A	1	EA	SUPPORT BRKT, 12 IN BURNER
15	952140D	D	1	EA	BURNER WELDMENT, 12 INCH SS

PARTS LIST					
ITEM	PART NUMBER	REV	QTY	UOM	DESCRIPTION
1	2600949101	-	1	EA	SCREW, 10-32 X 1/2, HEX, SS
2	2831851112	-	4	EA	BOLT, 3/8-16 X 3/4 HEX HEAD
3	2832-4201	-	1	EA	NUT, #10-32 HEX SS
4	2832-8904	-	4	EA	NUT, 3/8-16 CENTERLOCK
5	2833-4310	-	1	EA	WASHER, #10 EXT. STAR
6	3000022400	-	1	EA	SPARK IGNITER, NGK 5464
7	3100115100	-	1	EA	LUG, PUSH-ON F, .250 14-16GA NON INSUL.
8	53070	-	1	EA	FLAME SENSOR, 7.5 INCH
9	6032-0118	-	1	EA	LUG, RING 1/4 16-14GA VINYL
10	61026	-	1	EA	NIPPLE, 1 X 4 IN SCH 40 BLACK
11	61028	-	1	EA	UNION, 1 IN SCH 40 BLACK
12	681402	-	3.5	FT	WIRE, 14GA HIGH TEMP
13	706894	-	1	EA	TERM, TAB, #10
14	952103	A	1	EA	SUPPORT BRKT, 12 IN BURNER
15	952140D	D	1	EA	BURNER WELDMENT, 12 INCH SS

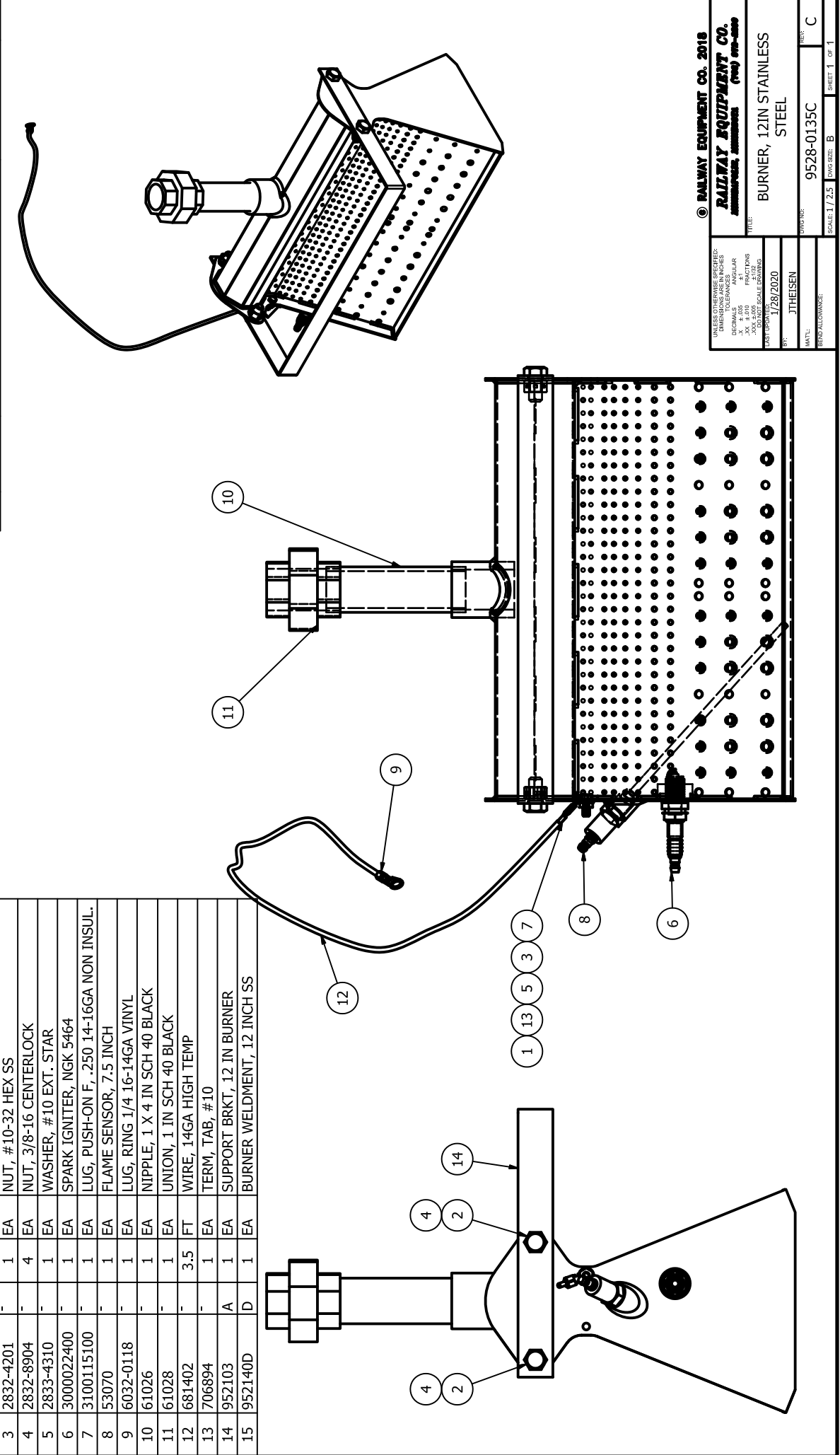

UNLESS OTHERWISE SPECIFIED:
 DIMENSIONS IN INCHES
 DECIMALS TO THIRDS PLACE
 ANGULAR TO NEAREST DEGREE
 .XX ± .010 FRACTIONS TO NEAREST 1/32
 .XX ± .010 FRACTIONS TO NEAREST 1/64
 .XX ± .010 FRACTIONS TO NEAREST 1/32
 .XX ± .010 FRACTIONS TO NEAREST 1/64
 .XX ± .010 FRACTIONS TO NEAREST 1/32
 .XX ± .010 FRACTIONS TO NEAREST 1/64

DATE: 1/28/2020
 BY: JTHEISEN
 MFG: RAILWAY EQUIPMENT CO. 2018
RAILWAY EQUIPMENT CO.
 12000 W. 12TH AVE. #100
 DENVER, CO 80202
 (303) 440-1000

TITLE: BURNER, 12IN STAINLESS STEEL
 DWG NO: 9528-0135C
 SCALE: 1/2.5
 DWG SIZE: B
 SHEET 1 OF 1

PARTS LIST

ITEM	PART NUMBER	REV	QTY	UOM	DESCRIPTION
1	16003	-	0.05	EA	RTV SILICONE CLEAR 10 OZ TUBE
2	1660000200	-	1	EA	FITTING, COMPRESSION 1/4" OD AIRLINE TO NPT 1/4" BRASS
3	1660000300	-	1	EA	FITTING, 1/4" NPT RIGHT ANGLE TEE FM BRASS
4	2831411429	-	2	EA	SCREW, #10-32 X 1-3/4 PANI PHIL SS
5	32002	-	0.3	SQFT	INSULATION, FIBERGLASS
6	60037	-	2	EA	BUSHING, ANTI-SHORT 3/4 IN FLEX
7	60061	-	3.5	FT	CONDUIT, FLEX 3/4 INCH STEEL
8	60071	-	1	EA	CONDUIT, FLEX CONNECTOR STRT 3/4 INCH STRAIGHT
9	60093	-	1	EA	CONDUIT, FLEX CONNECTOR 90
10	60168	-	72	IN	TUBING, 1/4INCH O.D. NYLON
11	6093-0100	-	4	EA	CABLE TIE, 4IN 0.10 WIDTH
12	61069	-	1	EA	MUFFLER / FILTER 1/4" BRASS
13	9338-0073A	A	1	EA	ASSY, DUCT PRESSURE SENSOR
14	952822B	B	1	EA	COVER, PRESSURE SENSOR 2 HP
15	952823A	A	1	EA	PLATE, PRESSURE SENSOR 3 AND 5 HP
16	9538-0039B	B	1	EA	ASSY, DUCT SENSOR EXT CABLE
17	R9538-0151A	A	1	EA	LABEL, ID

REVISION HISTORY

REV	ECO #	DESCRIPTION	DATE	BY
A	17-0016	NEW PART	5/11/2018	JT

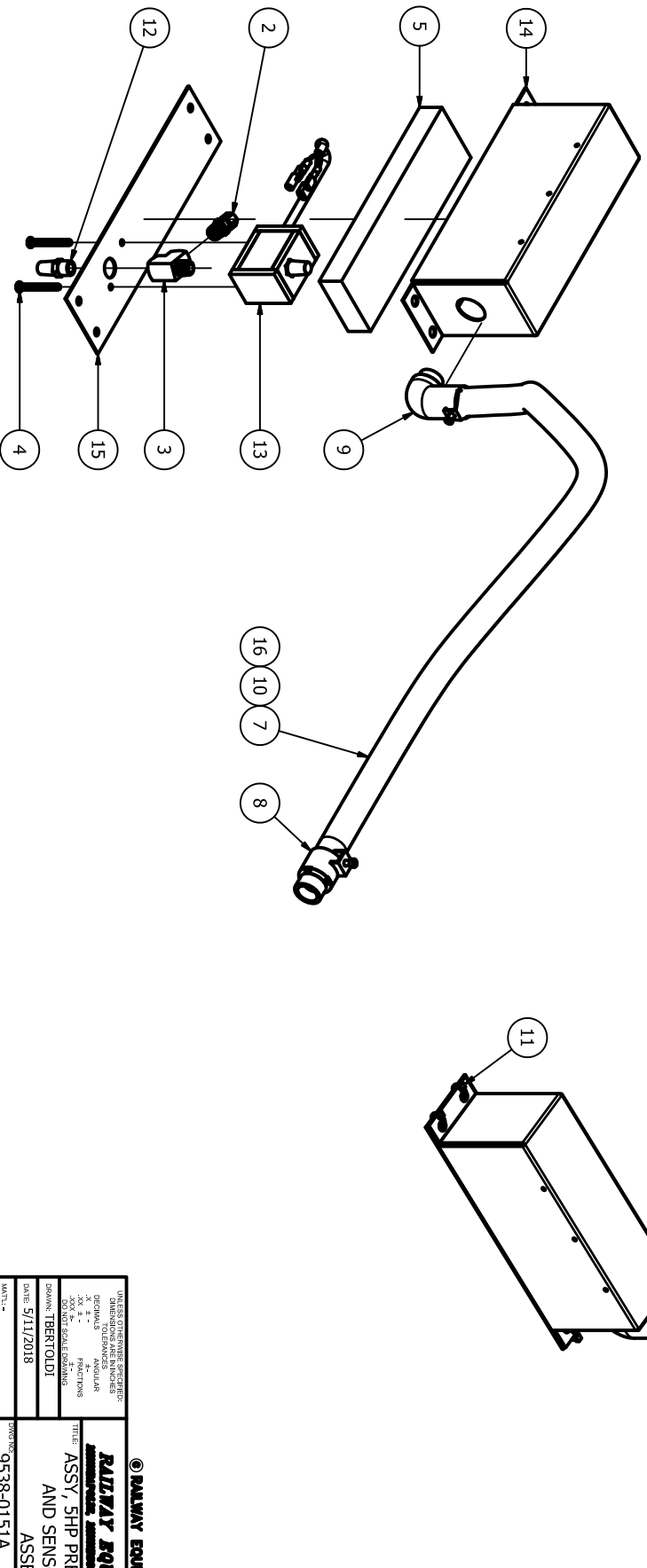

© RAILWAY EQUIPMENT CO. 2017

RAILWAY EQUIPMENT CO.
 10000 10th Street, Louisville, KY 40203
 (502) 426-0000

TITLE: ASSTY, 5HP PRESSURE SWITCH AND SENSOR BLOWER ASSEMBLY
 DRAWN: TBERTOLDI
 DATE: 5/11/2018
 DWG NO: 9538-0151A
 REV: A

UNLESS OTHERWISE SPECIFIED: DIMENSIONS ARE IN INCHES DECIMALS - ANGULAR X.X, X.X - FRACTIONS *NOT TO SCALE DRAWING	SCALE: 1/4"	DWG. NO: 9538-0151A	REV: A
DRAWN: TBERTOLDI	DATE: 5/11/2018	TITLE: ASSTY, 5HP PRESSURE SWITCH AND SENSOR BLOWER ASSEMBLY	
REVISIONS:	NO. 1	DATE: 5/11/2018	BY: JT
SCALE: 1/4"	DWG. NO: 9538-0151A	REV: A	

Pressure Switch Calibration

These steps describe how to calibrate the pressure switch to turn off when 90% of the air intake is blocked.

1. The Pressure Switch comes pre-calibrated based on the horsepower of the Gas Hot Air Blower. If adjustment is needed they can be adjusted between 0.12"wc to 5.0"wc. Turning the adjustment screw on the pressure switch has these effects to the pressure set point:
 - a. Clockwise (CW) = increase pressure set point
 - b. Counterclockwise = decrease pressure set point
2. Run the GHAB in a normal manner such that air flow and flame are present. If air flow cannot be proven, turn the Pressure Switch adjustment screw Counter Clockwise (CCW) until the air flow LED turns on.

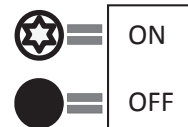
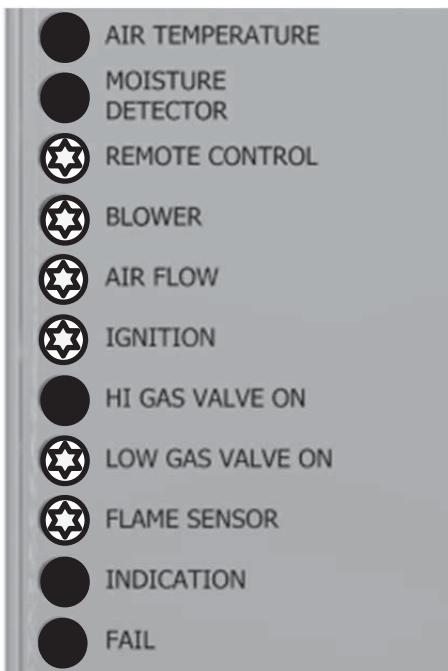

3. Block the air intake 90% with cardboard. The suction from the GHAB will hold the cardboard in place.

4. Turn the Pressure Switch adjustment screw Clockwise (CW) until the Air Flow LED on the control module turns off. It is now calibrated.

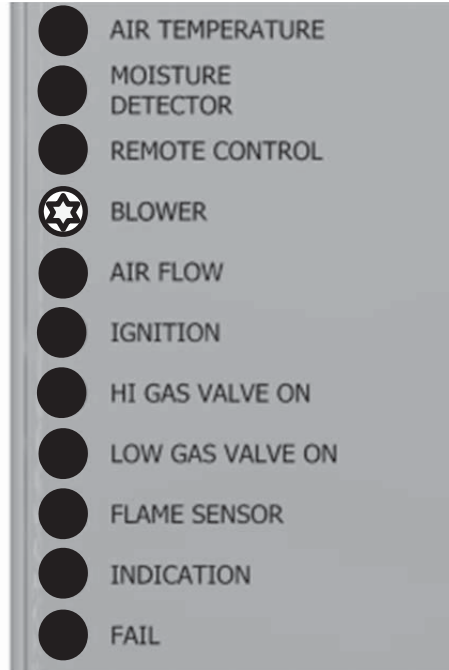

MENU SELECT STATUS

Outside Temp 0°F
Preset Value 38°F
Displays the current ambient temperature and temperature preset value.

Gas Pressure 0.0 IN
Duct Pressure 0.0 IN
Displays gas and duct pressure while running.

Rail Temp 0°F
Duct Temp 0°F
Displays the rail temperature and duct temperature.

Total Gas 0.0 FT
Reset Gas 0.0 FT
Total gas displays the calculated amount of gas that has been used. Reset is the same as total but it can be reset.

Hour Meter 0
Reset Hour 0
Total hours GHAB has been running. Reset is the same as total but it can be reset.

Tank Level 80%
Bat 4.5 V, Temp 0°F
Displays level of propane in percent full. Bat displays level of the tank monitor. Temp displays battery monitor temperature.

Name
Shows you the name for your unit.

MENU SELECT FACTORY DEFAULTS

Factory defaults is used to place all parameters back to factory default settings. Follow the message on the screen to do this.

MENU SELECT SET POINTS

Password
Push up or down to change the password. Use password 5 for critical setpoint.

Select Temperature
Setpoint 38°F
Push up or down to change the set point.

Select Run Timer
Value 0 Minutes
Push up or down to change the time.

Select Snow Timer
Value 30 Minutes
Push up or down to set time following a snow event.

Select Snow Sensor
Speed 1 Seconds
Push up or down to select from 1 to 60 seconds before snow cycle starts.

Select Snow Sensor Indication
OFF / ON

Select Fault Indication
OFF / ON

Select Start Delay
Value 0 Seconds
Push up or down to select start delay (10 sec increments).

Select Burner Operation
LOW, HIGH, AUTO, or AUTO OFF.

Operation Mode
NATURAL, PROPANE, COLD AIR, COLD AIR/PROPANE, or COLD NATURAL

Select Motor Size
Push up or down to select the motor you have for your unit.

Rail Temp 0.0 °F
Setpoint 60.0 °F
Push up or down to set the setpoint.

DuctTemp 0.0 °F
Setpoint 250.0 °F
Push up or down so set the setpoint.

Local With/ Without Air Temp
Push up or down to select.

Remote With/ Without Air Temp
Push up or down to select.

Auto Overtemp Reset
Push up or down to enable or disable.

Select F or C
Push up or down to select either °F or °C.

My IP Address
Displays the IP address.

Machine S/N
Displays the S/N for the GHAB unit.

Program Rev
Date
Displays the program revision and the date it was compiled on.

MENU SELECT FAULT HISTORY

Flame Loss 0
Flame On 0
Push up or down to clear.

Sail Loss 0
Sail On 0
Push up or down to clear.

Motor Current 0
Comm Reset 0
Push up or down to clear.

Motor V Fault 0
Overload 0
Push up or down to clear.

Gas Valve Leak 0
Pressure Fault 0
Push up or down to clear.

Duct Pressure Fault 0
Vap. Press Low 0
Push up or down to clear.

Gas Level Low 0
Push up or down to clear.

Over Temps Warning
Counter 0
Push up or down to clear.

Auto Overtemp Reset
Counter 0
Push up or down to clear.

Power Up Counter 0
Push up or down to clear.

Status Log