

OPERATING MANUAL

COMBO UNIT

5 HP

230V 1 PHASE AC DRIVE

460V 3 PHASE

GAS FIRED HOT AIR BLOWER

WITH 100KW ELECTRIC LOAD CAPACITY

TRACK SWITCH SNOW MELTER

WITH STEEL TIE DUCT

MANUFACTURED

BY

RECO

RAILWAY EQUIPMENT COMPANY

525 9th STREET SOUTH

DELANO, MINNESOTA 55328

TEL. 763-972-2200

FAX. 763-972-2900

E-Mail:

Technical Support: Techsupport@rwy.com

Sales: Sales@rwy.com

Table of Contents

1. Warnings and Cautions	1
2. General Information.....	5
2.1. Model Number Description.....	5
2.2. Standard Features	5
3. Component Description	8
3.1. Main Hot Air Blower (HAB) Unit.....	8
3.2. Standard Ductwork.....	10
3.3. Optional Ductwork.....	11
4. Installation.....	12
4.1. Tie Duct.....	12
4.2. Main HAB Unit.....	13
4.3. Point Nozzles and Track Ducts	15
4.4. Gas Connection	16
4.5. Changing the Gas Orifice.....	20
4.6. Electrical Connection	22
5. Control Module.....	24
5.1. Description	24
5.2. Set-Up and Adjustments.....	26
5.3. Password 0 and 5 Menus	27
5.3.1. Status.....	27
5.3.2. Factory Defaults.....	28
5.3.3. Set Points	29
5.3.4. Fault History	32
5.4. Push Buttons and LED Status Indicating Lights.....	33
5.4.1. Push Buttons	33
5.4.2. Led Status Indicating Lights	33
5.5. Operation.....	35
5.6. Fault Conditions	37
6. Seasonal Maintenance.....	42
6.1. Spring	42
6.2. Fall.....	42
7. Motor Greasing Procedure.....	43
8. Low Pressure Regulator Adjustment/Output Temp Test.....	44

9.	Troubleshooting	45
9.1.	Unit Does Not Start	45
9.2.	Unit Does Not Maintain Operation	45
9.3.	Low Heat Level.....	45
9.4.	Low Airflow	46
9.5.	Gas Valve	46
9.6.	High Heat Level	46
10.	Snow Detector.....	47
10.1.	Snow Detector Installation	47
10.2.	Snow Detector Operation	48
10.3.	Snow Detector Maintenance.....	48
10.4.	Snow Detector Troubleshooting.....	49
10.4.1.	No Heat on the Sensing Head	49
10.4.2.	Does Not Detect Moisture.....	49
10.4.3.	Constant Indication of Moisture Detection	49
11.	Specifications	50
12.	Drawings	51
13.	Limited Warranty	52

1. Warnings and Cautions



CAUTION

GENERAL HAZARD WARNING

FAILURE TO COMPLY WITH THE PRECAUTIONS AND INSTRUCTIONS PROVIDED WITH THIS HEATER, CAN RESULT IN DEATH, SERIOUS BODILY INJURY AND PROPERTY LOSS OR DAMAGE FROM HAZARDS OF FIRE, EXPLOSION, BURN, ASPHYXIATION, CARBON MONOXIDE POISONING, AND/OR ELECTRICAL SHOCK.

ONLY PERSONS WHO CAN UNDERSTAND AND FOLLOW THESE INSTRUCTIONS SHOULD USE OR SERVICE THIS HEATER.

IF YOU NEED ASSISTANCE OR HEATER INFORMATION, SUCH AS INSTRUCTION MANUALS, LABELS, ETC., CONTACT THE MANUFACTURER.



CAUTION

WARNING: FIRE, BURN, INHALATION, AND EXPLOSION HAZARD.

KEEP SOLID COMBUSTIBLES, SUCH AS BUILDING MATERIALS, PAPER OR CARDBOARD, A SAFE DISTANCE AWAY FROM THE HEATER AS RECOMMENDED BY THE INSTRUCTIONS. NEVER USE THE HEATER IN SPACES WHICH DO OR MAY CONTAIN VOLATILE OR AIRBORNE COMBUSTIBLES, OR PRODUCTS SUCH AS GASOLINE, SOLVENTS, PAINT THINNER, DUST PARTICLES OR UNKNOWN CHEMICALS.



CAUTION

NOT INTENDED FOR INDOOR USE. IT IS ONLY INTENDED FOR OUTDOOR USE.

WARNING: NOT FOR HOME OR RECREATIONAL VEHICLE USE.

The heater is designed and approved for use as a construction heater under ANSI Z83.7

We cannot anticipate every use which may be made of our heaters.
CHECK WITH LOCAL FIRE SAFETY AUTHORITY IF YOU HAVE QUESTIONS ABOUT APPLICATIONS.

Other standards govern the use of fuel gases and heat producing products in specific applications. Your local authority can advise you about these.

PLEASE READ THIS INSTRUCTION MANUAL ENTIRELY BEFORE HANDLING THIS MATERIAL OR ATTEMPTING TO INSTALL, OPERATE OR SERVICE THIS HOT AIR BLOWER SYSTEM.

PLEASE READ THE WARNINGS AND CAUTIONS LISTED BELOW.



SHEET METAL EDGES MAY BE VERY SHARP AND CAN CAUSE SEVERE CUTS OR LACERATIONS. PROTECTIVE GLOVES AND CLOTHING SHOULD BE WORN. USE CAUTION WHEN HANDLING ALL SHEET METAL COMPONENTS.



THE HOT AIR BLOWER TRACK SWITCH SNOW MELTER SYSTEM CAN BE OPERATED REMOTELY OR BY A SNOW DETECTOR SYSTEM. THEREFORE, OPERATION MAY BEGIN UNEXPECTEDLY. USE CAUTION WHEN IN THE AREA.



SYSTEM OPERATES WITH VARIOUS VOLTAGE LEVELS UP TO 600VAC. CONTACT WITH ELECTRICITY CAN BE HAZARDOUS OR LETHAL. MAKE SURE THAT THE MAIN CIRCUIT BREAKER IS TURNED OFF BEFORE ATTEMPTING TO SERVICE THIS SYSTEM. EVEN WITH CIRCUIT BREAKER OFF LINE VOLTAGE IS PRESENT AT THE TOP CIRCUIT BREAKER CONNECTIONS.



THIS SYSTEM CONTAINS A HIGH SPEED AIR FAN WHICH ROTATES AT UP TO 3600RPM AND CREATES FORCEFUL SUCTION WHEN OPERATING. DO NOT OPERATE THE BLOWER SYSTEM IF ANY OF THE DUCTWORK COMPONENTS HAVE BEEN REMOVED.



THIS SYSTEM OPERATES WITH NATURAL GAS OR PROPANE. BOTH ARE GASES WHICH ARE FLAMMABLE AND EXPLOSIVE. USE EXTREME CAUTION WHEN WORKING IN THE AREA. AVOID ANY OPEN FLAME, SPARKS OR OTHER SOURCE OF IGNITION.



THE OUTLET AIR TEMPERATURE FROM THIS GAS SNOW MELTER SYSTEM SHOULD NOT EXCEED 375°F FROM ANY NOZZLE OR DUCT. **DO NOT OPERATE THIS BLOWER SYSTEM IF THE OUTLET TEMPERATURE EXCEEDS 375°F.** AN ACCURATE THERMOMETER SHOULD BE USED TO REGULARLY CHECK THE OUTLET AIR TEMPERATURE. IF THE OUTLET TEMPERATURE EXCEEDS 375°F, CHECK TO MAKE SURE THAT THE FLOW OF AIR IS NOT RESTRICTED AT ANY POINT, THAT THE BLOWER/MOTOR ARE OPERATING PROPERLY, THAT THE CORRECT ORIFICE IS USED FOR THE TYPE OF FUEL USED, AND THAT THE REGULATOR(S) ARE PROPERLY ADJUSTED FOR THE FUEL BEING USED. CONSULT RAILWAY EQUIPMENT COMPANY IF YOU ARE UNABLE TO OPERATE THIS GAS SNOW MELTER SYSTEM BELOW 375°F.

A HIGH TEMPERATURE LIMIT SYSTEM HAS BEEN INCORPORATED INTO ALL RAILWAY EQUIPMENT COMPANY GAS SNOW MELTER SYSTEMS BEGINNING IN 1999. RAILWAY EQUIPMENT COMPANY ALSO HAS A HIGH TEMPERATURE LIMIT MODIFICATION KIT THAT CAN BE ADDED TO GAS SNOW MELTER SYSTEMS MANUFACTURED PRIOR TO 1999. IT IS RECOMMENDED THAT THIS HIGH TEMPERATURE LIMIT SYSTEM BE INSTALLED AND USED. CONSULT RAILWAY EQUIPMENT TO ORDER THE HIGH TEMPERATURE MODIFICATION KIT, OR IF YOU NEED ASSISTANCE REGARDING THE HIGH TEMPERATURE LIMIT SYSTEM.

THIS SNOW MELTER SYSTEM HAS BEEN DESIGNED TO PROVIDE DEPENDABLE EFFECTIVE OPERATION IN ALL WEATHER CONDITIONS WITHOUT SWITCH COVERS. SWITCH COVERS MAY CAUSE HIGHER AIR TEMPERATURES. IF SWITCH COVERS ARE USED, YOU MUST DETERMINE A SAFE OPERATING AIR TEMPERATURE AND ADJUST BURNER PARAMETERS ACCORDINGLY. ADJUSTMENT OF BURNER PARAMETERS MAY NEGATIVELY AFFECT BURNER PERFORMANCE AND COMBUSTION CHARACTERISTICS TO THE EXTENT THAT THE BURNER MAY BE UNABLE TO MAINTAIN COMBUSTION. CONSULT RAILWAY EQUIPMENT COMPANY REGARDING BURNER OPERATING PARAMETERS.

TWO (2) COMPLETE INSTRUCTION MANUALS HAVE BEEN INCLUDED WITH THIS SNOW MELTER SYSTEM. PLEASE KEEP ONE OF THE MANUALS WITH THE SYSTEM AFTER INSTALLATION. ANYONE OPERATING OR SERVICING THIS SNOW MELTER SYSTEM SHOULD READ THE MANUAL ENTIRELY BEFORE PROCEEDING.

IF YOU HAVE ANY QUESTIONS CONCERNING THE MANUFACTURE, DESIGN, FUNCTION, INSTALLATION, OPERATION OR MAINTENANCE, CONTACT RAILWAY EQUIPMENT COMPANY BEFORE PROCEEDING.

2. General Information

2.1. Model Number Description

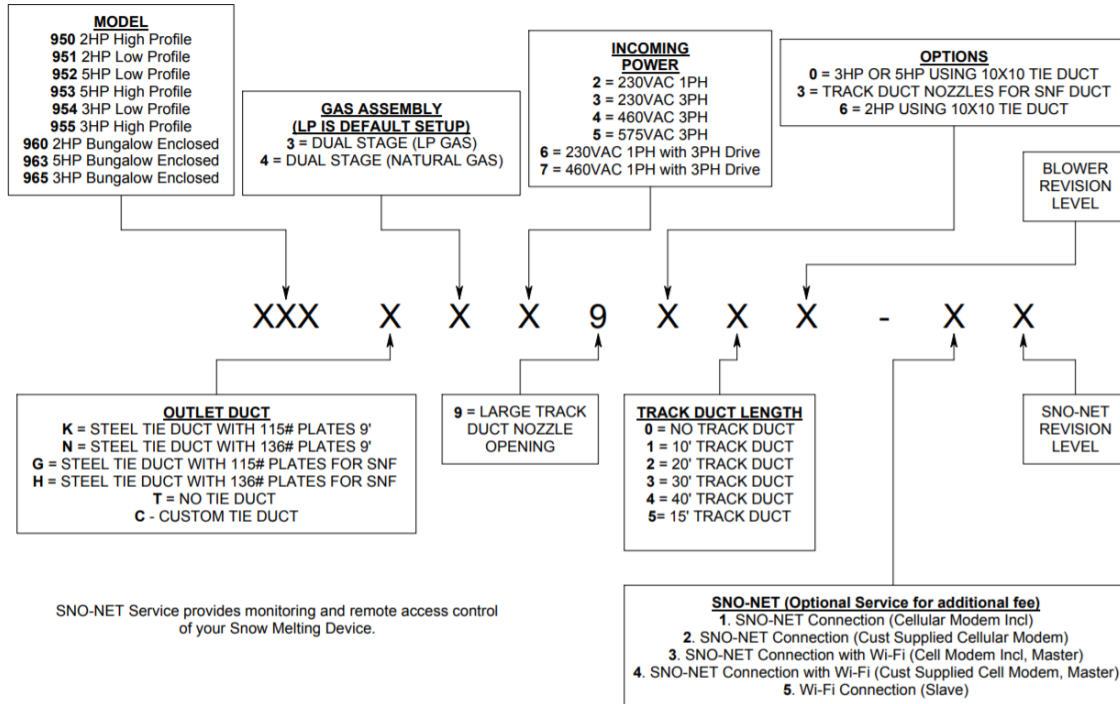

2.2. Standard Features

Here is a list of standard feature that come with the GHAB:

- GHAB complies with AREMA 12.6.10.
- Gas fired operation, allows for both propane and natural gas (convertible in the field).
- Two stage operation that allows savings on fuel costs. Second stage runs at 50% output of the first stage.
- Direct drive motor, totally enclosed fan cooled.
- High efficiency, quiet operation blower.
- Remote operation via contact closure (low voltage, low current) with timed shut off.
- Built-in snow detector system (requires Snow Detector assembly option).
- Auto-Off-Local switch.
- High temperature limit thermostat/shut off.
- Adjustable air temperature control.
- Adjustable rail temperature control.
- Reply indication via GHAB contact closure.
- Fail indication via GHAB contact closure.
- Main circuit breaker.

- Audible tone before blower startup
- Weather tight gasketed control enclosure
- Status indicating lights for all control functions
- Start delay timer for sequential startup
- Run timer for timed operation
- Selectable "Transparent" snow detector operation
- Snow detect timer
- All ductwork and nozzles are thermally and electrically isolated from tracks
- Quick-release track duct
- Blower motor starter with overload protection
- Remote auxiliary gas valve (115VAC) supplied connection
- Gas line accessories:
 - Manual gas valve
 - Gas line strainer
 - Low pressure regulator
 - Flexible gas line connection pipe
- Elevated air intake
- Adjustable delay for start-up (10 sec. -5 min.)
- Complete flame safeguard control:
 - Pre-ignition air purge
 - Air flow proving switch
 - Direct spark ignition
 - Flame proving sensor
 - Post shut off air purge 4 min.
 - Automatic shut off on loss of flame or air flow
 - Leaky gas valve detection
 - Automatic retry on flame loss
 - Automatic reset on flame safeguard control
 - All flame safeguard controls CSA listed
- All components mounted and wired within main unit – no external wiring required except for remote control, indications, optional snow detectors, external gas valve and rail temp sensor.
- Galvanized case constructed of 14-gauge steel, high temperature powder coated finish.
- Convenient panel access to high efficiency burner, flame sensor and spark igniter.
- Galvanized steel adjustable mounting foundations.

- Standard ductwork: flame duct with straight insulated flexible duct and heavy duty insulated offset duct connects to main tie duct electrically insulated between rails, 24 inch (minimum) switch point nozzles.

The following items are recommended for use with propane gas service:

Tank "pigtail" with POL/POL fittings (P/N 45038-12" or 60127-36")

High pressure regulator (P/N 45103)

Gas line strainer (P/N 45040)

Remote solenoid valve (P/N 45036)

OR

Complete Propane Package (P/N 9458-0100)

3. Component Description

3.1. Main Hot Air Blower (HAB) Unit

a. Main Circuit Breaker

Provides main over-current protection and manual on-off control of electrical power.

b. Motor Contactor

Provides automatic blower motor control, with high current contacts.

c. Motor Overload Relay

Protects the blower motor from an over-current condition.

d. Control Module

Provides complete control of operation. See separate description and details, section 5.

e. Control Transformer

Provides control power for the control module and other control components. The multi-tapped secondary provides 36VAC CT and 17VAC CT. The primary has 115VAC input plus a 230VAC step-up winding and 12.6VAC CT windings.

f. Ignition Transformer

Provides 6000VAC to the spark igniter during the ignition sequence.

g. Airflow Switch

Located in the flame duct, the pressure switch indicates proper airflow before and during burner operation.

h. Burner

Contains the actual flame. Also holds the spark igniter and the flame-sensing rod.

i. Propane/Natural Gas Orifice Plate

Controls the rate of flow of gas to the burner.

j. Spark Igniter

The spark plug type igniter provides spark for the burner. The spark igniter is momentary - sparks only until the flame has been established.

k. Flame Detection Rod

The flame detection rod monitors the flame at the burner nozzle using the rectification principle. This provides a signal to the control module if a proper flame exists.

l. Air Temperature Sensor

This is a thermocouple sensor for monitoring the ambient air temperature. The flexible magnetic end of the sensor should be placed so it is shaded by the GHAB unit, generally on the north side.

m. Rail Temperature Sensor

This is a thermocouple sensor for monitoring the actual rail temperature.

n. Gas Valve

These are electric solenoid valves which control the flow of gas for burner operation. It is controlled directly from the control module.

o. Blower Motor

The motor is totally enclosed and fan cooled.

p. Blower

The high efficiency blower wheel is dynamically balanced for smooth and quiet operation.

q. Buzzer

The buzzer will sound a 10-second tone immediately before the motor contactor is energized.

3.2. Standard Ductwork

**DO NOT WALK ON EQUIPMENT. THIS
INCLUDES TRACK DUCTS AND
FIBERGLASS COVERS.**

a. Heat Duct

The first section of ductwork attached to the main HAB unit. This duct contains the burner, air flow switch, spark igniter and the duct pressure sensor.

b. Flex Duct

Connects the heat duct to the offset duct. It is a section of flexible duct, enclosed in an insulated sheet metal wrapper.

c. Heavy Duty Offset Duct

Connects the flex duct to the tie outlet duct. This duct provides an 8" offset and encloses the air mixer.

d. Tie Outlet Duct

The outlet duct extends under the rails in place of a tie and directs the airflow to the point nozzles and track ducts. The rail attaches to the duct using tie plates and E clips. The tie plates are electrically insulated from the rail using an insulating kit. There are six openings in the top for point nozzles and track duct nozzles. Refer to the drawing page for the duct layout.

e. Track Ducts

These ducts rest on brackets on the ties and the outlet duct. They are installed over the track duct nozzles. The track ducts consist of a 5' point, a 5' mid, and 10' sections to complete the desired length.

f. Track Duct Nozzle

This attaches to the inner two rectangular openings on the top of the outlet duct. This directs airflow down the length of the switch through the track ducts.

g. Track Duct Nozzle Isolating Kit

This is an electrically insulating gasket with insulating washers and hardware to provide isolation between the nozzles and the outlet duct. Refer to drawing 9278-0027 for proper installation.

h. Quick Change Nozzle Plate

This plate allows for quick removal or installation of nozzles to the tie duct, by simply loosening of four bolts the nozzle assembly can be removed or installed.

i. Track Duct Support Bracket

These brackets are used to secure the track duct in position. Refer to drawing 92774.

j. Switch Point Nozzle

These nozzles direct heated air down the switch point. They are mounted on the outlet duct. They can be adjusted for proper airflow direction. Nozzles may be shortened by up to 10” for proper fit.

k. Point Nozzle Isolating Kit

This is an electrically insulating gasket with insulating washers and hardware to provide isolation between the nozzles and the outlet duct. Refer to drawing 9278-0021 for proper installation.

3.3. Optional Ductwork

a. Extension Ducts

Extension ducts of various lengths are available to meet specific requirements. These are insulated and enclosed in a metal wrapper. Make sure the duct is mounted in the correct orientation, as there is an access opening underneath the insulating wrapper cover. If additional duct extensions are required, this assembly can be added between the outlet duct and the offset duct.

b. 7’ Track Duct

These track ducts are seven feet long. They are often mounted outside of the track near the switch machine. A kit is available (P/N 9278-0270) that includes a 7’ track duct, a track duct nozzle and a track duct isolation kit.

NOTE: OTHER DUCTWORK ASSEMBLIES ARE AVAILABLE. CONSULT THE FACTORY FOR SPECIAL DUCTWORK NEEDS.

4. Installation

**DO NOT WALK ON EQUIPMENT. THIS
INCLUDES TRACK DUCTS AND
FIBERGLASS COVERS.**

NOTE: The installation should be done in this order:

1. Tie Duct Outlet Duct/Offset Duct
2. Main HAB Unit/Flex Duct
3. Point Nozzles and Track Duct
4. Gas
5. Changing the Gas Orifice
6. Electrical

**PLEASE READ THROUGH THE ENTIRE
INSTRUCTIONS BEFORE BEGINNING THE INSTALLATION**

4.1. Tie Duct

1. Remove the appropriate tie. Choose the tie that will result in the point nozzles being as close to the switch point as possible without interfering with normal switch operation. The distance from the center of the tie duct to the end of the point nozzles is 33". If necessary, up to 10" may be cut off each point nozzle.
2. Remove sufficient ballast to provide at least 14" clearance from the bottom of the rails.
3. Carefully slip the tie duct under the rails and position it so that the rails are directly above the tie plates. Ensure that the tie duct is centered between the adjacent ties.
4. Place a rubber pad on the tie plate, then using a suitable lever, raise one end of the tie duct until the rail lies correctly on the pad on the tie plate. Place two e-clip insulators, one on each side of rail, in place and then fasten the rail to the tie plate using two of the four 927248 rail clips. Use a heavy hammer or maul to drive the clips securely into place.
5. While keeping the tie duct supported in place, firmly pack ballast under the tie duct from the rail out to the end.

6. Repeat steps 4 and 5 for the other end of the tie duct.
7.
 - i. Remove the end flange plate nearest the HAB by loosening the six retainer bolts.
 - ii. Install the two-foot heavy duty offset duct (P/N 9278-3402) to the tie duct using hardware and gasket supplied with the offset duct.
8. Firmly repack ballast under the entire tie duct.

4.2. Main HAB Unit

1. The main HAB unit has four slotted mounting holes on 15-1/2" x 34-1/2" centers.
2. Refer to Foundation Assembly drawing for the assembly of the optional mounting foundation.
3. Use the provided GHAB positioning drawings to determine the approximate position and height of the mounting foundation. The top of the foundation should be placed 4"-6" below the height of the ties. This will allow final adjustment of the HAB unit.
NOTE: The drawing shows a standard HAB unit, but can be used for the low profile series, also.
4. Excavate and place the foundation in its proper location.
5. Refer again to the drawing of the Foundation Assembly, detail A, showing the mounting bolt arrangement. Attach four 3/4-10 x 8" hex bolts in the slotted holes of the blower base, using a washer on each side of the blower base and a hex nut.
6. Thread a hex nut about halfway onto each bolt.
7. Place the blower unit on the foundation using a flat washer on the top and bottom of the foundation and another hex nut on the bottom. The slotted holes in the foundation will allow for side-to-side adjustment, and the slotted holes in the HAB base will allow front-to-back adjustment. However, do not tighten the mounting nuts yet.
8. Install the 30" flex duct onto the HAB flame duct.

- 9.** Now adjust the HAB unit side to side, up or down, and forward or backward to obtain the proper alignment of the heat duct to the offset duct. It may be necessary to adjust the position of the offset/outlet duct assembly. The adjustments should be made so that there is no stress on any of the ductwork; also flex duct should measure 30". Again, leave the mounting nuts loose for now.
- 10.** Connect the other end of the flex duct to the HD offset duct.
- 11.** With all components in the proper position, the foundation nuts may now be tightened.
- 12.** The fill can now be replaced around the mounting foundations.
- 13.** Adjustable air intake screens. To start the GHAB in a new location, set the intake screens in the closed position. If there is a moisture problem, where frost builds up on the intake screens, the intake screens can be set in the open position to improve the airflow into the blower.

4.3. Point Nozzles and Track Ducts

NOTE: Refer to the GHAB positioning drawing for the track duct and point nozzle position. LH and RH Point/Track Nozzle Assemblies:

1. Attach point/track nozzle assembly RH (P/N 9508-4000) and point/track nozzle assembly LH (P/N 9508-4001) to the openings in the tie duct. Position assemblies for proper airflow direction.
2. Assemble the individual track duct sections into two complete track duct sections. The mid and heel sections contain splices wrapped around the outside of the duct. Unhook the clips to remove the three cover pieces. The bottom can now be removed from the duct.

NOTE: To assemble the splice:

- i. Center the bottom splice piece on the seam between the two track ducts.
 - ii. Connect the center cover piece over the seam. (**NOTE:** The center cover piece has slots to contain the bolts on the track duct).
 - iii. Finally, connect the two end cover pieces.
3. Lay the track ducts on the rail ties alongside where they will be installed.
4. Refer to the drawing 92774. Place the track duct support brackets in position on the ties so that one is near the heel end and one near each joint. Use the lag bolts to fasten the brackets in place. Lay the track duct on the bracket bases. Place the hold-down straps over the track ducts. Attach the hold-down strap to the track duct support brackets by inserting the spring clip into the strap.
5. Push in the square knockouts in the track ducts where airflow is desired. The knockout should be pushed in and bent completely so that no portion of the knockout obstructs the airflow in the duct. Knockout tabs that are not bent back completely will obstruct the airflow as it moves through the track duct resulting in reduced air pressure and airflow further along the track duct.

4.4. Gas Connection



CAUTION

When tightening gas line fittings or components to the HAB unit, be sure that you do not rotate the pipe that enters the blower unit. This could cause the gas control valve inside the blower unit to rotate also. Please reference the label attached just above the pipe that enters the blower unit.

NOTE: Optional items available from Railway Equipment Co. are denoted by *

1. The following items are shipped in a carton marked "GAS LINE ACCESSORIES", along with various pipe fittings, so that they may be arranged to fit the particular installation. Refer to Instruction Sheet R9500-0027 included with Gas Line Accessories for the proper placement of these components:
 - Flexible pipe
 - Y strainer (s)
 - Manual shutoff valve
 - Low pressure regulator
 - Regulator Spring, if included

2. The following items are available as optional items:
 - * High Pressure Regulator (P/N 45103)
 - * 36" Gas tank "pigtail" (P/N 60127)
 - * 12" Gas tank "pigtail" (P/N 45038)
 - * Remote gas valve (P/N 45036)

NOTE: A propane package is available (P/N 9458-0100) that includes a 36" tank pigtail, high pressure regulator, gas line strainer, gauge, remote solenoid valve in a pole mount enclosure, and a 4X4X8' post.

FOR NATURAL GAS INSTALLATION PROCEED TO STEP 5

3. * Install the copper "pigtail" to the propane tank. Each end of the pigtail is a reverse thread.

4. * Install the high pressure (red) regulator to the pigtail. Remember reverse thread on the pigtail connection.

5. Install the "Y" strainer downstream (but near) the high pressure regulator, or natural gas source.

6. * Install the remote gas valve downstream (but near) the "Y" strainer. Electrical connections from the remote gas valve are made to terminal posts TS1-10 (115VAC) and NEUTRAL on the HAB unit. The valve must be mounted with the inlet and outlet horizontal, and the coil upwards.
7. Install adequate size gas pipe from the remote tank location to the main HAB unit. Check with local gas supplier for sizing recommendations.
8. The remaining gas line components are attached to the HAB unit, as shown on the drawing, layout, GHAB Gas Line. Remember to position the regulator vent fitting facing sideways so that moisture will not enter the regulator.
9. If you are having problems adjusting the gas pressure low enough on 5 HP units, the spring in the low pressure regulator must be changed. To change the spring, complete the following steps:
 - i. Try adjusting the low pressure regulator for proper fuel pressure. If it can't be adjusted, follow instructions listed below for changing the regulator spring.
 - ii. Turn power off and close manual gas valve.
 - iii. Remove the plug on top of the regulator.
 - iv. Turn the plug inside the regulator counter-clockwise until it can be removed.
 - v. Replace the red spring with the violet spring provided in the gas accessory kit.
 - vi. Replace the top plug.
 - vii. Go to gas pressure menu to adjust.

FOR INSTALLATION ABOVE 2000 FOOT ELEVATION:

- i. Turn the manual gas valve to "ON" position and turn power on.
- ii. Push the "LOCAL" button.
- iii. Place the burner control select in the hi-only position.

- iv. After the 30-second pre-purge period, the unit will ignite. Check the gas pressure display. Adjust the white plug in regulator until the display reads 11" water column for propane or 7" water column for natural gas.
NOTE: Clockwise to increase pressure, counter-clockwise to decrease pressure.
- v. Let the GHAB run for a 10 minute period.
- vi. After the 10 minute period, take temperature readings at both point nozzles.
- vii. Determine the ambient temperature at the location and subtract the ambient temperature from the point nozzle reading. This temperature should not exceed 250°F for optimum efficiency.
- viii. If the temperature is above 250°F, adjust the gas pressure at the low pressure regulator down (1" w.c. at a time) until you reach the desired temperature.
- ix. Replace the top plug.

FOR INSTALLATION BELOW 2000 FOOT ELEVATION:

- i. Turn the manual gas valve to "ON" position and turn the power on.
- ii. Push the "LOCAL" button.
- iii. Place the burner control select in the hi-only position.
- iv. After the 30-second pre-purge period, the unit will ignite. Check the gas pressure display. Adjust the white plug in regulator until the display reads 11" water column for propane or 7" water column for natural gas.
NOTE: Clockwise to increase pressure, counter-clockwise to decrease pressure.
- v. Let the GHAB run for a 10 minute period.
- vi. After the 10 minute period, take temperature readings at both point nozzles.

- vii.** Determine the ambient temperature at the location and subtract the ambient temperature from the point nozzle reading. This temperature should not exceed 250°F for optimum efficiency.
- viii.** If the temperature is above 250°F, adjust the gas pressure at the low pressure regulator down (1" w.c. at a time) until you reach the desired temperature.
- ix.** Replace the top plug.

4.5. Changing the Gas Orifice

1. This unit uses an orifice plate instead of individual orifices. The orifice plate contains the orifices for both propane and natural gas for both stages of operation.

CAUTION

2. Make sure the main circuit breaker is in the OFF position and the manual gas valve is closed before working on the HAB unit.
3. Remove the bottom intake cover from the HAB unit.
4. On the right hand side of the gas assembly you will see the orifice plate. The orifice plate has a tab facing out that says NG for natural gas or LP for propane. This will tell you how the unit is currently set up.
5. To change from one fuel to the other:
 - i. There are four bolts on each gas coupling plate. You need to fully remove the top two bolts on each coupling plate and you need to back out the bottom two bolts on each coupling plate 1/2 to 3/4 of an inch.
 - ii. On the inlet (left hand side of the gas assembly) you need to remove the two bolts securing the gas valve assembly to the outside of the GHAB, and loosen the U-bolt.
 - iii. You can now carefully slide the gas assembly to the left to free the orifice plate.
 - iv. The orifice plate can be pulled away from the outlet manifold and then up and out.
NOTE: Take care removing the orifice plate so you don't damage the O-rings.
 - v. The orifice plate can now be flipped over for the other fuel and re-inserted in between the gas coupling and outlet manifold.
NOTE: Take care replacing the orifice plate so you don't damage the O-rings.
 - vi. Slide the gas assembly back to the right and insert the top bolts on the coupling plates.

- vii.** Verify the tab facing out on the orifice plate is now the correct fuel.
 - viii.** Evenly tighten the eight bolts on the coupling plates.
 - ix.** Replace the bolts on the inlet bracket (outside of GHAB), and tighten the U-bolt hardware.
 - x.** Re-install the lower intake cover.
- 6.** Turn on power and manual gas valve.
- 7.** Test unit and check regulator adjustment and output temp.

4.6. Electrical Connection

a. Knockouts

There are knockouts on the side and bottom of the control enclosure for incoming electrical wires.

b. Incoming Power

The incoming power should be connected directly to the main circuit breaker.

SPECIAL NOTE FOR 3 PHASE UNITS ONLY

WHEN THE MAIN HOT AIR BLOWER UNIT IS STARTED FOR THE FIRST TIME, VERIFY THAT THE MOTOR IS TURNING IN THE CORRECT DIRECTION. TO DO THIS, REMOVE THE BOTTOM AIR INTAKE COVER AND CHECK TO SEE IF THE FAN IS ROTATING IN THE CCW DIRECTION. THERE WILL BE AN ARROW SHOWING THE CORRECT ROTATION DIRECTION. IF THE FAN IS NOT ROTATING IN THE CORRECT DIRECTION, SWAP 2 OF THE INPUT WIRES.

c. Ground

The chassis ground TS1-G should be tied directly to earth ground.



CAUTION

THE 230 / 480 / 575 VAC SUPPLY LINES SHOULD BE SIZED TO ALLOW FOR THE AC MOTOR START-UP CURRENT. REFER TO THE SPECIFICATIONS PAGE FOR START-UP CURRENT. UNDERSIZED CONDUCTORS OR LONG WIRE RUNS COULD DAMAGE THE MOTOR.

SPECIAL NOTE: THE CONTROL CHASSIS AND THE REST OF THE MAIN HAB UNIT MUST BE CONNECTED TO GROUND. THE RUBBER PAD BETWEEN THE RAIL AND TIE PLATE ALONG WITH THE E-CLIP INSULATORS WILL INSULATE THE MAIN UNIT FROM THE TRACKS.

d. Control Input

Remote operator control can be provided by a circuit closure applied between terminal posts TS1-1 and TS1-2.

e. Indication

Reply indication can be done two ways:

- i. Dry contact closure: Terminal posts TS1-3 and TS1-4 will provide a dry contact closure for indication when the unit is operating under remote control.

- ii. +24 VDC: Place a jumper between terminal posts TS1-2 and TS1-4. +24 VDC indication is now present on post TS1-3 with common at terminal post TS1-6.

f. Fail

Reply fail can be done two ways:

- i. Dry contact closure: Terminal posts TS1-5 and TS1-4 will provide a dry contact closure for fail when the unit is in a fault mode.
- ii. +24 VDC: Place a jumper between terminal posts TS1-2 and TS1-4. +24 VDC fail is now present on post TS1-5 with common at terminal post TS1-6.

g. Duct Work High Temperature Sensor (P/N 9338-0355)

- i. On the tie duct, remove the two bolts holding down the overtemp sensor cover. Install the sensor onto the duct using the two bolts that were removed.
- ii. Run conduit along duct work back to HAB enclosure; connect connector to enclosure knock out; tighten (**NOTE:** Cut conduit to length if needed).
- iii. Run wires from sensor into enclosure and plug connectors into OVERTEMP (RED) J10 and OVERTEMP (BROWN) J36 located on the control module.
- iv. Use two clamps (P/N 60086) to secure conduit to the side of duct work using existing screws.

<p>CAUTION DO NOT INSTALL OVERTEMP SENSOR ON FLEX DUCT.</p>
--

h. Rail Temp Sensor (P/N 9508-0415)

- i. Attach the sensor to the bottom of the stock rail in front of the point nozzle. Attach conduit to ties using the provided clamps.
- ii. Run wires from sensor into enclosure and plug connector into THERMOCOUPLE CONNECTIONS RAIL TEMP (YELLOW) located on the control module.

5. Control Module

5.1. Description

The hot air blower control module contains all of the elements and functions necessary for advanced snow melter operation. The unique dual-chip microcomputer has been programmed with logic and timing sequences to provide complete heater control as well as operational control and system interface. Some of the many features included in the control module are:

- Auto-Off-Local selector switch
- Adjustable air temperature setting
- Built-in snow detector (Requires Optional Snow Detector Head)
- Adjustable start-up delay sequence
- Adjustable run timer for timed or continuous operation
- Adjustable snow detect timer for use with optional snow detector
- Operator control and indication
- Remote fault reset
- Audible tone before blower start-up
- Input/output status indication lights:

Inputs:

- Air temperature
- Remote Control
- Moisture Detector One or two snow detector(s) (Optional)
- Airflow switch
- Flame Sensor

Outputs:

- Blower motor
- Ignition
- Hi Gas valve
- Low Gas valve
- Indication
- Fail



Flame safety control:

10 second tone before blower turn on

Air flow proving

30 second pre-purge before ignition

Direct spark ignition

10 second maximum ignition period before lock-out

Rectification type flame rod sensor

Automatic retry on flame loss

4 minute post-purge period after gas valve turn-off

Automatic reset

Fault if flame does not go out after gas valve is commanded off

5.2. Set-Up and Adjustments

To change settings and adjust times do the following:

Right Arrow Button

Pushing the right arrow button will cycle forward through the menus. Each time you press the right arrow button you will advance one menu selection.

Left Arrow Button

Pushing the left arrow button will cycle back through the menus. Each time you press the left arrow button you will move back one menu selection.

Up Arrow Button

The up arrow button allows you to increase values and switch through menu categories.

NOTE: Values will be saved.

Down Arrow Button

The down arrow button allows you to decrease the values and switch through menu categories.

NOTE: Values will be saved.

NOTE: After you are have finished changing the settings / values and you do not touch any of the buttons for 15 seconds, you will see the following screen. This screen just lets you know that your current settings and values are being saved.



5.3. Password 0 and 5 Menus

NOTE: The following items listed below are for password 5. Password 0 has the same set of menu categories but does not have all the same menu selections in each category. It will be denoted which menu selections you can only see with password 5

The controller has 4 menu categories, they are:

1. Status
2. Factory Defaults
3. Set Points
4. Faults History

5.3.1. Status

a. Outside Temp and Preset Value

Displays the current ambient temperature and temperature preset value. If the ambient temperature is below the preset value, the unit will start if requested.

b. Gas Pressure and Duct Pressure

Gas pressure is the actual differential pressure at the burner. The unit of measure is inches of water ("H₂O). To view gas pressure, the burner should be burning. The correct setting should be approximately 11"H₂O for propane and 7"H₂O for natural gas. While adjusting, the burner should be in high only. Adjust regulator to change gas pressure value. Duct temperature is the actual duct temperature in degrees F or C.

c. Rail Temp and Duct Temp

Rail temperature is the actual rail temperature in degrees F or C. Duct temperature is the actual duct temperature in degrees F or C.

d. Total Gas and Reset Gas

(Password 5)

Total gas displays the calculated amount of gas that has been used. The unit of measure is gallons if propane is selected. The unit of measure is cubic feet if natural gas is selected. Reset gas is the same as total gas except it can be reset. To reset, press the down button.

e. Hours Meter and Reset Hour

(Password 5)

Hour meter displays the total hours that GHAB has been running. Reset hour is the same as hour meter except it can be reset. To reset, press the down button.

f. Tank Level, Bat and Temp

Tank level displays the actual level of propane tank in percent full (optional tank level monitor must be installed). Bat displays the battery level of the tank monitor. Temp displays the temperature in the battery monitor.

g. Name

(Password 5)

This screen tells the name you have entered for the unit.

5.3.2. Factory Defaults

Factory default is used to place all parameters back to factory default settings. To restore to factory default, select FACTORY DEFAULTS in the menu selection. Press the right arrow button to display “FOR FACTORY DEFAULTS PRESS DOWN BUTTON,” then press the down arrow button to restore factory defaults.

5.3.3. Set Points

a. Password

A password is needed to access the advanced menus. To enter in the password, use the up or down arrow buttons. Password 5 allows advanced menu items to be changed.

b. Select Temperature Setpoint

The ambient temperature below which the unit will energize is set on this screen. When the outside temperature is below this setpoint, the unit will be allowed to operate if requested. The factory default is 38°F (3°C). The range is from 0°F to 100°F (-18°C to 38°C).

c. Select Run Timer Value

The run timer can be set from 0 to 1000 minutes. If zero is selected, the outputs will operate continuously, until control on is disabled. If another value is selected, the unit will run until the run timer counts down to zero, after which the unit will shut down and drop indication. The unit can be restarted by removing the contact closure between TB2-1 and 2, then reinstalling it. If Run Timer Pulse Mode is activated, the minimum run time value is 10 minutes. The factory default setpoint is 60 minutes.

d. Select Snow Timer Value

The snow timer can be set from 10 to 1000 minutes. The snow time starts counting down when the moisture detector no longer sees snow. The factory default setpoint is 60 minutes.

e. Select Snow Sensor Speed

Snow sense speed sets the delay time after the moisture detector sees moisture and starts the snow cycle. The delay time can be set from 1 to 60 seconds. The moisture sensor must see moisture for entire time to start cycle.

f. Select Snow Indication

(Password 5)

The choices are OFF or ON. With snow indication off, indication will remain off during snow time if no faults are present. With snow indication on, indication will remain on during snow time if no faults are present.

g. Select Fault Indication

(Password 5)

The choices are OFF or ON. With fault indication off, indication will remain off if faults are present. With fault indication on, indication will remain on if faults are present.

h. Select Start Delay Value

(Password 5)

The start delay timer can be set from 0 to 250 seconds in 10 second increments. It is used to delay the start of GHAB so when several blowers are at the same location they do not start at same time.

i. Select Burner Operation

The choices are LOW, HIGH, AUTO, and AUTO OFF:

- LOW - 50% BTU output of Hi with or without the rail sensor.
- HIGH - 100% BTU output with or without rail sensor.
- AUTO - Switches between high and low dependent on the rail & duct temperature sensor and setpoint.
NOTE: If no rail sensor is connected, it will run at high gas. Units with only single stage installed, should select high only.
- AUTO WITH 100KW LOW - Switches between high gas and the 100KW Electric Heaters depending on the rail & duct temperature sensor and setpoint.
NOTE: If no rail sensor is connected, it will run with only the electric heaters.

j. Operation Mode

(Password 5)

The choices are NATURAL, PROPANE, COLD AIR, COLD AIR/PROPANE, and COLD NATURAL:

- NATURAL - The GHAB's burner is fueled by natural gas.
- PROPANE - The GHAB's burner is fueled by propane.
- COLD AIR - The GHAB will turn its blower on with air temperature. It will not use a burner.
- COLD AIR/PROPANE - The GHAB will turn its blower on with air temperature. It will then turn its propane burner on with moisture or control.
- COLD AIR/NATURAL - The GHAB will turn its blower on with air temperature. It will then turn its natural gas burner on with moisture or control.

k. Select Motor Size

The choices are:

2 HP 230V 1PH, 3 HP 230V 1PH, 5 HP 230V 1PH,
2 HP 460V 3PH, 3 HP 460V 3PH, 5 HP 460V 3PH,
2 HP 575V 3PH, 3 HP 575V 3PH, 5 HP 575V 3PH,
2 HP 3PH Drive, 3 HP 3PH Drive, 5 HP 3PH Drive
2 HP 230V 3PH, 3 HP 230V 3PH, 5 HP 230V 3PH

l. Rail Temp Setpoint

This can be set from 0°F to 280°F (-18°C to 138°C).

m. Duct Temp Setpoint

This can be set from 150°F to 250°F (66°C to 121°C).

n. Local With/Without Air Temperature

(Password 5)

Sets the local feature to, or not to, be dependent on the air temperature.

o. Remote With/Without Air Temperature

(Password 5)

Sets the remote feature to, or not to, be dependent on the air temperature.

p. Auto Overtemp Reset

(Password 5)

Auto overtemp reset will reset the overtemp once it has been triggered.

q. Select F or C

(Password 5)

Sets the temperature scale to either Fahrenheit or Celsius.

r. My IP Address

This is the IP address for your GHAB unit.

s. Machine S/N

(Password 5)

Machine serial # is the serial number of the whole GHAB unit.

t. Program Rev and Date

(Password 5)

Shows the program revision and the date it was compiled.

5.3.4. Fault History

NOTE: Some faults may not show in Fault History until there is an actual fault. Press the up or down arrow button to reset fault count.

a. Flame Loss and Flame On

Flame loss counter is total count of flame loss faults. Flame on counter is total count of flame on faults.

b. Sail Loss and Sail On

Sail loss counter is total count of sail loss faults. Sail on counter is total count of sail on faults.

c. Motor Current and Comm Reset

Motor current fault is total count of motor current faults. Comm reset fault is total count of communication reset faults.

d. Motor V Fault and Overload

Motor volts low or high counter. Overloads counter is total motor overloads faults.

e. Gas Valve Leak and Pressure Fault

Gas valve counter is total count of leaking gas valve faults. Gas pressure low or high counter.

f. Duct Pressure Fault and Vap. Press Low

Duct pressure fault counter is total count of duct pressure faults. Vaporization low fault counter is total count of vaporization low faults.

g. Gas Level

Informs if the gas level is low or high.

h. Over Temp Warning Counter

Counts the total number of Over Temp warnings.

i. Auto Overtemp Reset Counter

Counts the total number of times the Over Temp was reset.

j. Power Up Counter

(Password 5)

Counts the number of times the module has been powered up.

k. Status Log

Shows the status log history.

5.4. Push Buttons and LED Status Indicating Lights

5.4.1. Push Buttons

a. Auto

This position will allow operation by placing a circuit closure across terminal posts 1 and 2. It will also allow operation by an optional snow detector.

b. Off

If off, GHAB cannot be run from remote or snow detector.

c. Local

If LOCAL without air temp parameter is enabled, pushing the LOCAL button enables the snow melter regardless of outside air temperature. The snow melter will remain on until LOCAL is turned off. This is useful for hot weather testing.

5.4.2. Led Status Indicating Lights

a. Air Temperature

On when the ambient air temperature is below set point.

b. Moisture Detector

On when the optional snow detector sensing head(s) senses moisture.

c. Remote Control

On when there is a circuit closure across terminal posts 1 and 2.

d. Blower

On when the controller has turned on the output to the blower motor contactor.

e. Air Flow

On when the sail switch in the air stream is sensing adequate airflow.

f. Ignition

On when the controller has enabled the output to the ignition transformer.

g. Hi Gas Valve On

On when the controller has enabled the output to the high gas valve.

h. Low Gas Valve On

On when the controller has enabled the output to the low gas valve.

i. Flame Sensor

On when the flame sensing determines that there is proper combustion.

j. Indication

On when there is a circuit closure across terminal posts 1 and 2 and the unit is operating, or the air temperature is above the set point. Also may be on when there is a fault condition under snow detector.

k. Fail

This LED is on whenever a fault is present.

5.5. Operation

With AUTO selected, the unit can be activated by applying a circuit closure between terminals TS1-1 and 2. If the outside temperature is above set point, the unit will not start a snow melt sequence, but will turn on the indication LED. It will provide a relay contact closure between TS1-3 and 4 to indicate to the remote station that the unit is operational. If the “REMOTE WITHOUT AIR TEMP” parameter is set, the temperature sensor will be overridden, and a contact closure will start a snow melt sequence even if the air temperature is above the set point.

If a circuit closure exists between TS1-1 and 2, and the air temperature is below set point, the unit will begin a snow melt sequence. The unit executes a 0 to 300 seconds time delay depending on the setting of the START DELAY TIMER. Then, a 10 second audible tone sounds as a warning that the blower motor is about to turn on.

The airflow switch is checked to see if it is closed. If it is, the blower will display SAIL SWITCH ON FAULT.

If the airflow switch is open, the motor will turn on. After the blower motor is turned on, the airflow switch is monitored. It closes if airflow is normal. If it does not close within 10 seconds (or 30 seconds for an AC drive) after blower turn-on, the blower displays SAIL SWITCH OFF FAULT. When the airflow switch closes, a 30 seconds pre-purge time will start. After the pre-purge time is completed the gas valve opens, the ignition turns on and the burner is monitored for a normal flame condition. If a flame is not detected within 10 seconds, the gas valve is closed, the ignition spark is removed and the blower displays NO FLAME DETECTED FAULT.

If a normal flame condition is detected the “indication” contact closure is established between TS1-3 and 4. The unit will run for a period of time determined by the setting of the RUN TIMER. If the run timer is set at “0” the unit will continue to run until the circuit closure between TS1-1 and 2 is removed.

If the blower is equipped with the two stage gas valve option and the rail temp sensor is installed, then under normal operation when the rail reaches the preset temperature setting, the low gas valve will open and the high gas valve will close. This will result in a fuel reduction of 50%. When the rail falls below the programmed temperature, the high gas valve will open and the low gas valve will close resulting in the burner returning to 100% capacity.

If the blower is equipped with the two stage gas valve option and the duct temp sensor is installed, then under normal operation when the duct reaches the preset duct temperature setting, the low gas valve will open and the high gas valve will close. This will result in a

fuel reduction of 50%. When the duct falls below the programmed temperature, the high gas valve will open and the low gas valve will close resulting in the burner returning to 100% capacity. If the duct temp sensor sees a temperature above 325°F (163°C) both gas valves will be disabled. This prevents over temps.

There is a burner control adjustment available in the control module adjustments that allow the burner to be set to high only, low only or automatic controlled by the rail temp sensor. If the two-stage option is not installed, the burner control switch should be set to high only. Refer to section 5.3.3 Select Burner Operation.

SNOW DETECTOR OPERATION: If the unit is operating with one or two optional snow detector assemblies and moisture is detected by either (or both), a snow melt sequence will begin, provided that the air temperature is below the set point. The unit will start as described in section 5.3.3 Select Snow Timer.

5.6. Fault Conditions

a. Sail Switch On Fault

During startup the processor checks the status of the airflow switch. If the airflow switch is closed or shorted the blower motor will turn on and the blower will run a 4-minute purge to try to clear the airflow switch. The motor will then shut off and sit idle for 1 minute. Upon completion of this 5-minute cycle, the blower will once again check the airflow switch for proper operation. If the airflow switch still shows that it is closed, it will run the 5-minute loop again. This will repeat until fault is cleared or blower is no longer called for.

b. Sail Switch Off Fault

Sail switch off fault is set when blower is running and air flow switch is open. After the fault is set the blower motor will run a 4-minute purge to try to clear the airflow switch. The motor will then shut off and sit idle for 1 minute. Upon completion of this 5-minute cycle, the blower will once again check the airflow switch for proper operation. If the airflow switch still shows that it is open it will run the 5-minute loop again. This will repeat until fault is cleared or blower is no longer called for. Check to see if the sail switch is free to move and if there are any obstructions in duct work.

c. No Flame Detected Fault

No flame detected fault is set when blower is running and air flow switch is closed with gas valve open. If no flame is detected within 10 seconds the fault will be set. After the fault is set the blower motor will run a 4-minute purge to try to clear the flame rod. The motor will then shut off and sit idle for 1 minute. Upon completion of this 5-minute cycle, the blower will once again check the flame rod for proper operation. If no flame is present it will run the 5-minute loop again. This will repeat until fault is cleared or blower is no longer called for. Check to see if the flame rod is shorted to ground, the flame rod is loose, the flame rod is dirty or if the insulators is fully installed so that no moisture can short out the flame rod.

d. Flame Detected On Fault Gas Valve Failure

Flame detected on fault is set when blower is running and air flow switch is closed with gas valve closed. If flame is detected before gas valve is opened the fault will be set. The blower will continue to run and the buzzer fail indication will be set. The circuit breaker must be power cycled to clear this fault. Check to see if the flame rod is shorted to ground, the flame rod is loose, the flame rod is dirty or if the insulators is fully installed so that no moisture can short out the flame rod.

e. Gas Valve Failure

During the blower shutdown operation if the unit senses flame after the post-purge, the unit will not shutdown. Instead it will go into gas valve failure mode. In this mode the blower continues to run, the reply will also indicate a problem, and the buzzer will sound. The unit will lock out all other operations and will not be able to be reset except at the unit itself.

f. Check Fuse #1 24 VDC Power

Fuse # 1 is tripped. Check the following circuits:

- Overtemp switch and wiring.
- Check TS1-2 +24 control on wiring.
- After problem is corrected, leave power off for 30 seconds and fuse will reset.

g. Check Fuse #2 Ignition Transformer

Fuse # 2 is tripped. Check the following circuits:

- Ignition transformer and wiring.
- After problem is corrected, leave power off for 30 seconds and fuse will reset.

h. Check Fuse #3 Gas Valve / Sail Switch

Fuse # 3 is tripped. Check the following circuits:

- Check sail switch and wiring.
- Check hi and low gas valve and wiring.
- Check external gas valve and wiring.
- After problem is corrected, leave power off for 30 seconds and fuse will reset.

i. Check Fuse #4 Blower Motor

Fuse # 4 is tripped. Check the following circuits:

- Check blower motor contactor and wiring.
- After problem is corrected, leave power off for 30 seconds and fuse will reset.

j. Check Fuse #6 Snow Head #1

Fuse # 6 is tripped. Check the following circuits:

- Check snow detector head #1 and wiring.
- Check gas pressure sensor and wiring.
- Check duct pressure sensor and wiring.
- After problem is corrected, leave power off for 30 seconds and fuse will reset.

k. Check Fuse #7 Snow Head #2

Fuse # 7 is tripped. Check the following circuits:

- Check snow detector head # 2 and wiring.
- Check sail switch and wiring.
- After problem is corrected, leave power off for 30 seconds and fuse will reset.

l. Check Fuse #10 Pressure/Bat Charger

Fuse # 10 is tripped. Check the following circuits:

- Check pressure sensor.
- Check 24V supply for battery backup.
- After problem is corrected, leave power off for 30 seconds and fuse will reset.

m. Overtemp Fix Problem Press Decrease

Overtemp sensor has tripped. If the temperature inside the Tie duct exceeds 375°F, it will cause the ductwork overtemp circuit to trip, shutting down the HAB system. Only pushing the down arrow button will reset the unit, giving opportunity to check the cause of the overtemp condition.

n. Overtemp Fix Problem Press Decrease ___ Min

The overtemp sensor has tripped. The HAB system will shut down for some time period then it will reset the unit. **NOTE:** AUTO OVERTEMP RESET must be enable in order to see this fault.

o. Overtemp Warning Restart In ___ Sec

If the temperature is close to overtemp value, the unit will restart in a certain time period.

p. Overtemp Missing Install Overtemp

Caused by missing overtemp sensor.

q. Motor Voltage Low

Motor voltage low is caused by inadequate electrical service supply. During motor start up if motor voltage drops below 190VAC, the motor will eventually be damaged. If this under-voltage occurs, an error will be set. Press the down arrow button to clear the fault.

r. Motor Voltage High

Motor voltage high is caused by high motor voltage. It can also be caused by high voltage from the electric company.

s. Motor Overload, Reset Overload Device

High motor current will trip the motor overload on the control panel. This device is connected to the bottom of the motor contactor on the control panel. Reset by pressing the red button on the device. Check unit for high motor current, bad bearings, or obstructions in the blower wheel.

t. Motor Current Low

Caused by low motor current.

u. Motor Current High

Motor current high is caused when sensed current is 3 amps over motor name plate for 20 seconds. Check motor for high current, bad bearings, obstruction in blower wheel.

v. Gas Pressure Low

Gas pressure low is caused by supply gas pressure during operation dropping to a low level. Check gas delivery system.

w. Gas Pressure High

Gas pressure high is caused by high gas pressure going to the burner. Check gas delivery system. Adjust the regulator on the gas delivery system to lower the gas pressure.

x. Duct Pressure Low

Duct pressure low is caused by not enough duct back pressure. Possible causes are missing flame cover or missing duct work.

y. Duct Pressure High

Duct pressure high is caused by too much duct back pressure. Possible causes are duct work obstructions.

z. Propane Tank Low Warning Fill Tank

Propane tank low is caused by low propane tank level. **NOTE:** Propane tank level monitor must be installed and setup, for this warning to appear.

aa. Tank Vaporization Pressure Low Warning

Tank vaporization pressure low warning is caused by low tank temperatures.

bb. Utility Power Lost

Utility power lost is caused by no incoming AC voltage. There must be a battery backup in order to receive this fault.

cc. Additional Fuses

The control module has 4 additional fuses on the module that require replacement if they are open.

- **FUSE 5** (P/N 51179) FUSE, MINI 5 AMP is above the display and fuses the indication common on terminal 4.
- **FUSE 8** (P/N 51225) MDA 10 AMP is to the right of the display and fuses the 120VAC power to the module.
- **FUSE 9** (P/N 51209) FUSE, .5 AMP, is below the display and fuses the pressure sensors.
- **FUSE 11** (P/N 51179) FUSE, MINI 5AMP is in the top left corner of the control module. This fuse is in the 24VDC control on circuit.

NOTE: Remove the module cover to access F5, F8 and F9. F11 is visible with the cover installed.

6. Seasonal Maintenance

To perform seasonal maintenance on your GHAB units, please follow the steps below, depending on which season you are in.

6.1. Spring

1. Turn off gas source.
2. Turn off electric power at source.
3. Disconnect and remove the control module. Store in a clean, dry place.
4. Turn off manual gas valve.

6.2. Fall

1. Check all ductwork for clear airflow. Ensure that the point and track duct nozzle screens are not damaged and are completely covering the openings. Make sure that no debris or rodents have obstructed any area of the ductwork.
2. Inspect the track duct nozzles for proper operation.
3. Remove the flame duct cover. Check the burner. Make sure the spark igniter plug and flame rods are in good, clean condition. Check the wiring to make sure rodent or vibration have not damaged the insulation.
4. Check the airflow sail switch to make sure it is operating properly.
5. Replace the flame duct cover.
6. Install the control module and connect the wires.
7. Turn on the gas source.
8. Turn on the manual gas valve.
9. Turn on the electric power at source.
10. Perform the gas pressure regulator adjustment procedure as described on the following page of this manual.
11. Perform a flame failure test:
 - a. Push the LOCAL button.
 - b. Turn off the manual gas valve.
 - c. Turn on the main circuit breaker.
 - d. After 40 seconds (plus any start delay period) the fault message NO FLAME DETECTED FAULT should be displayed. If the fault does not appear, the control module is faulty and should be replaced.
12. Check the air temperature for proper setting.

7. Motor Greasing Procedure

Follow this procedure to properly grease the motor you have for your unit. This procedure is only for, if you have, a 3 HP gas hot air blower unit, a 5 HP gas hot air blower unit, or a cold air blower unit.

1. Before you begin the process of lubricating the bearings, please advise:
WARNING: Do not touch electrical connections before you first ensure that power has been disconnected. Electrical shock can cause serious or fatal injury.
WARNING: Surface temperatures of motor enclosures may reach temperatures which can cause discomfort or injury to personnel accidentally coming into contact with hot surfaces. Protection should be provided by the user to protect against accidental contact with hot surfaces. Failure to observe this precaution could result in bodily injury.
2. Once what is stated above in step one is taken into consideration and done, you now need to make sure that you are in a stationary position to lubricate the bearings and that the motor is warm.
3. Locate the two grease Zerk's at the top of each end of the motor and clean each Zerk. Cleaning is important to prevent any unwanted filth to be transferred into the motor.
4. Locate the weep holes on the bottom of the motor. Clean them to remove any unwanted grease or filth. These need to be clean in order to allow excess grease to leave the bearings.
5. Now select one of the Zerk's to be used to add more grease into the motor.
NOTE: The correct grease to use for the motor is **Aeroshell 7**.
6. Attach a grease gun to one of the Zerk's. Make sure you are using Aeroshell 7 and add a small amount of grease. It is recommended that you only squeeze the grease gun handle once or twice to satisfy the amount needed.
7. Remove the grease gun and allow the motor to run for 15 minutes to let out any excess grease from the weep holes.
8. After the 15 minutes, wipe the weep holes again if any excess grease is released and you are finished.

NOTE: You need to perform this greasing procedure every 5500 hours of use to make sure your motor is being maintained properly.

8. Low Pressure Regulator Adjustment/Output Temp Test

1. Push the LOCAL button.
2. Turn the manual gas valve to “ON” position and turn power on.
3. Place the burner control in the hi-only position. See section 5.3.3 Select Burner Operation.
4. After the 30-second pre-purge period, the unit will ignite. Check the gas pressure value by removing the regulator top plug. Adjust the regulator until the gauge reads 11” water column for propane or 7” water column for natural gas.
NOTE: Clockwise to increase pressure, counter-clockwise to decrease pressure.
5. Let the GHAB run for a 10 minute period.
6. After the 10 minute period, take temperature readings at both point nozzles.
7. Determine the ambient temperature at the location and subtract the ambient temperature from the point nozzle reading. This temperature should not exceed 250°F for optimum efficiency.
8. If the temperature is above 250°F, adjust the gas pressure at the low pressure regulator down (1” w.c. at a time) until you reach the desired temperature.
9. Replace the top plug.
10. Return all switches to their normal operating position.

9. Troubleshooting

9.1. Unit Does Not Start

1. Check circuit breaker.
2. Check control fuse 11.
3. Check for 18VAC between the following points:
 - a. TS1-6 and TS1-7
 - b. TS1-6 and TS1-8
 - c. Change T1 control transformer if either measurement is incorrect.
4. Check for air temperature below set point.
5. Is the control module programmed for a start-up delay?
6. Monitor the fault display on the control module.
7. Turn the circuit breaker off, and then reset the motor overload relay. The motor overload relay is adjustable. It should be set for the motor name plate current.

9.2. Unit Does Not Maintain Operation

1. Check the fuel supply. Refer to section 8, step#4.
2. Check 230VAC and 115VAC from either leg to the center tap neutral (with the unit running). It must be within +10% to -10%.
3. Check the burner. The burner must be clean and free of carbon.
4. The flame rod should be clean and secure.
5. Check the wire from the flame rod to the control module for continuity. Pull the white plug connector on the lower right side of the control module. Use an Ohmmeter to measure continuity from the terminal of the flame rod to the white connector. The reading should be less than 50 KOhms.

9.3. Low Heat Level

1. Perform a regulator adjustment/output temp test refer to section 8.
2. Check the fuel supply.
3. Make sure the burner is clean.
4. Make sure the orifice plate is installed for the fuel being used.
5. Check the low pressure regulator.
6. Check to see if the burner control is on low only or if it is in auto and the Rail Temp Sensor setting is forcing it to low output.

9.4. Low Airflow

1. Check for obstructions in all ductwork and the air intake.
2. If there is frost buildup on the air intake screen, move the screen to the “open” position.
3. Check the voltage and current levels on the blower motor.
4. Make sure knockouts on the track duct are pushed all the way back in the track duct.
5. Check the spacing between the inlet cone and the blower wheel. The gap should be less than 1/16 of an inch.
6. Perform the pressure switch adjustment.
7. Make sure the blower wheel is turning in the right direction.

9.5. Gas Valve



CAUTION

**CHECK THE AREA TO BE SURE THERE ARE NO
LINGERING GAS FUMES BEFORE DOING
ANYTHING WHICH MAY CAUSE A SPARK!**

1. Turn off gas to the blower.
2. Turn off power to the blower.
3. Check the gas valve for obstructions.
4. Check the gas valve for proper operation.

9.6. High Heat Level

1. Check for proper orifice installation.
2. Perform the low pressure regulator and Temp Test found in section 8.

10.Snow Detector

10.1. Snow Detector Installation

1. The snow detector sensing circuitry is contained within the control module. All that is required for snow detector operation is to connect the sensing head(s).
2. Either one or two sensing heads may be used.
3. Each sensing head has three lead wires; black, white, and green. Connect as follows:
 - a. Green: one or both connected to TS1-6
 - b. Black #1: connected to TS1-7
 - c. Black #2: connected to TS1-8
 - d. White: one or both connected to TS1-9

NOTE: Refer to the diagrams when connecting wires for the sensing heads. It is important to properly connect the sensing head wires. Improper connection of the sensing head wires may result in damage to the control module and/or the sensing head.

4. To operate more than one HAB unit from a HAB unit that is controlled by a snow detector(s), connect terminal posts #6 together and terminal posts #9 together (do not connect terminal post #6 to terminal post #9). When connecting snow detectors to more than one HAB unit, first connect one HAB. Then connect the snow detector to one more HAB. If the snow detector does not operate properly, exchange L1 and L2 on the newest HAB circuit breaker.

NOTE: BE SURE L1 AND L2 ARE DE-ENERGIZED BEFORE EXCHANGING THEM. Continue to add HABs to the snow detector in the same manner until all the desired HABs are connected. DO NOT EXCEED 200' CABLE LENGTH (18 AWG WIRE).

5. The sensing heads should be mounted in a vertical position.

NOTE: Experience has shown that positioning a snow detector sensing head in the switch area between the ties and between the switch point and the track duct is effective. A second sensing head is then placed away from the switch area, such as on a bungalow or pole.

10.2. Snow Detector Operation

NOTE: A snow detector sensing head only detects moisture. With temperature sensing capability, the HAB unit assumes moisture is due to snow when the air temperature is below set point. All operating functions are similar to remote operation with the following exceptions:

1. Indication

During normal operation under snow detector control, the indication contact across terminal posts 3 and 4 will not be closed.

2. Snow Detector Run Timer

During remote operation, if the snow detector senses moisture, the unit will operate according to the settings. The unit will then operate for the duration of the run timer setting.

3. Fault Condition

A fault condition under snow detector control will cause the indication contact across terminal posts TS-3 and TS-4 to close. To reset the unit after a fault condition, momentarily apply a circuit closure between terminal posts TS-1 and TS-2 with pushing the AUTO button. The unit may now be operated either under remote control or snow detector control.

10.3. Snow Detector Maintenance

The snow detector sensing head contains a small, self-regulating heater that will melt snow or ice into water. The sensing head relies on moisture to create a low resistance circuit path. The heater will also cause the moisture to evaporate within a short period. If the surface becomes non-conductive due to contamination by grease or oil, the sensing head will not operate. To ensure effective and dependable snow detector operation, it is important to inspect the sensing heads frequently and clean them thoroughly if necessary. Use a solution of water and mild detergent or isopropyl alcohol to clean the sensing grid. Use a clean, dry cloth to wipe the grid. Make sure there is no residue left on the surface.

10.4. Snow Detector Troubleshooting

NOTE: A newly-installed snow detector sensing head should operate 15-20 minutes to allow the internal heater to reach normal operating temperature.

10.4.1. No Heat on the Sensing Head

1. Check for voltage between terminal post 6 and 7, and between terminal post 6 and 8. It should be 18VAC (+2VAC). If not:
 - a. Check the display on the control module.
 - b. The control transformer may be defective.
 - c. There may be a bad circuit connection.
2. Remove the black and the green lead wires from the terminal posts. Check resistance between them. If resistance is greater than 10 ohms, the sensing head is defective and should be replaced.

10.4.2. Does Not Detect Moisture

1. Clean the snow detector as described in section 10.3.
 2. If unit still does not detect moisture, check the wiring connections between detector head and terminal posts.
 3. If unit still does not detect moisture, replace the control module with a known good control module. If still not operating properly, replace the sensing head.
- NOTE:** If a snow detector head becomes saturated with moisture, it can sometimes be restored to normal operation by removing it and “baking” it in a conventional oven for several hours. Do not exceed 150°F.

10.4.3. Constant Indication of Moisture Detection

1. Clean the snow detector heads as described in section 10.3.
2. Remove white lead(s) from terminal post 9. If moisture indication is still on, the control module is defective and should be replaced.

11.Specifications

VOLTAGE:	230VAC, 1PH 60HZ 600 AMP (AC DRIVE)
MOTOR:	5 HP, 3450RPM, TEFC 21 Amp starting current 21 Amp running current
VOLTAGE:	460VAC, 3PH 60HZ 150 AMP
MOTOR:	5 HP, 3450RPM, TEFC 47 Amp starting current 5.8 Amp running current
AIRFLOW:	3600 CFM
COMBUSTION RATE:	1,000,000 BTU/HR 420,000 BTU/HR
FUEL:	Propane or Natural Gas
FLOW RATE:	Natural Gas: 1,000 CFH/420 CFH Propane: 400 CFH/168 CFH 11 GPH/4.6 GPH
KW OUTPUT:	100KW
INDICATION CONTACTS:	30VDC 1A or 125VAC 300mA
INCOMING GAS PRESSURE:	Low Pressure Regulator: 2 PSI – 10 PSI Optional High-Pressure Regulator: Max of 150 PSI
UNIT WEIGHT:	650 lbs. (295 kg)

12. Drawings

COMBO UNIT 5HP 230V 1PH AC DRIVE W/ 100KW	9755-3610
CONTROL PANEL 5HP 230V 1PH AC DRIVE	9755-0181
COMBO UNIT 5HP 460V 3PH W/ 100KW	9755-3400
CONTROL PANEL 5HP 460V 3PH	9755-0183
TIE DUCT ASSEMBLY 136# QUICK CHANGE	9528-4815
TIE DUCT ASSEMBLY 115# QUICK CHANGE	9528-4615
POINT / TRACK ASSEMBLY RH	9508-4000
POINT / TRACK ASSEMBLY LH	9508-4001
OUTSIDE TRACK ASSEMBLY LH	9508-4002
OUTSIDE TRACK ASSEMBLY RH	9508-4003
NOZZLE TRACK DUCT ASSEMBLY	927490
ISOLATION KIT, TIE DUCT POINT NOZZLE	9278-0021
ISOLATION KIT, TIE DUCT TRACK NOZZLE	9278-0027
GHAB FOUNDATION	9288-0302
HEAVY DUTY OFFSET DUCT	9528-3404
2' INSULATED FLEX DUCT	9528-5222
TRACK DUCT, POINT LG. NOZZLE 10 FT	9278-1205
TRACK DUCT, 5' MID	9278-0227
TRACK DUCT, 10', MID	9278-1201
TRACK DUCT, 10', HEEL	9278-1202
FLEX NOZZLE KIT	9278-9500
TRACK DUCT	9278-0233
TRACK DUCT SUPPORT BRACKET ASSEMBLY	92774
LAYOUT, GHAB GAS LINE	R9520-0027
GAS PIPING, 2 STAGE	9528-0237
AIR TEMP SENSOR, 5' MAGNETIC	9508-0404
BURNER ASSEMBLY	9528-0135
ASSY, 5 HP PRESSURE SENSOR	9538-0151
PRESSURE SWITCH CALIBRATION	
FLOWCHART	

13.Limited Warranty

Railway Equipment Co., Inc. (“Railway”) warrants all of its products to be free from defects in material and workmanship when used under specified operating conditions and within specified limits. Railway’s warranty shall extend for a period of two (2) years from the date of shipment to the original purchaser.

This warranty is expressly in lieu of and excludes all other expressed or implied warranties, including but not limited to warranties of merchantability and fitness for a particular purpose.

Railway, its agents, or representatives shall in no circumstance be liable for any direct, indirect, special, penal, or consequential loss or damage of any nature resulting from the malfunction of the product.

Remedies under this warranty are expressly limited to repair or replacement of the product at the sole discretion of Railway.

Before returning any defective product to Railway, contact the factory at the address or telephone number at the bottom of this article for a Return Merchandise Authorization number and instructions as to how and where the return is to be shipped. Materials received without this authorization will be returned at the customer’s expense.

Products returned to Railway under warranty must be shipped freight prepaid, and return freight charges for repaired or replaced products, in or out of warranty, will be at customer’s expense.

Railway reserves the right to reject any warranty claim on a product that has been altered by the user or damaged in shipping due to inadequate packaging or mishandling by freight carrier.

By returning a product to Railway the owner grants permission to Railway to open and disassemble the product as required for evaluation. Railway has the sole responsibility for determining the cause and nature of failure, and Railway’s determination with regard thereto shall be final. Railway reserves the right to repair or replace any unit at its sole discretion.

A returned product that is found, upon inspection by Railway, to be operational within specification is subject to an inspection and testing fee, regardless of its warranty period.

Railway’s liability on any claim of any kind (including negligence) for any loss or damage arising out of or resulting from this agreement, or from the performance of breach thereof, of from the products or services furnished hereunder, shall in no case exceed the price of the specific product or service which gives rise to the claim. All such liability shall terminate upon the expiration of the warranty period of two (2) years, as hereinabove stated.

The furnishing of advice or other assistance without separate compensation therefore will not subject Railway to any liability, either in contract, warranty, tort (including negligence) or otherwise.

Any alteration or modification of the product, or addition on non-Railway components to the product, unless expressly permitted by Railway in its documentation, will void warranty coverage.

This warranty is non-transferable, and warranty coverage is limited to initial user only.

Installation and/or use of the product shall demonstrate acceptance of the terms of this warranty.

Each of the foregoing paragraphs in this article will apply to the full extent permitted by law. The invalidity, in whole or part, of any paragraph will not affect the remainder of such paragraph or any other paragraph.

RAILWAY EQUIPMENT CO.

525 9th Street South, Delano, Minnesota 55328 USA

Tel. (763) 972-2200 Fax (763) 972-2900

E-Mail - mail@rwy.com

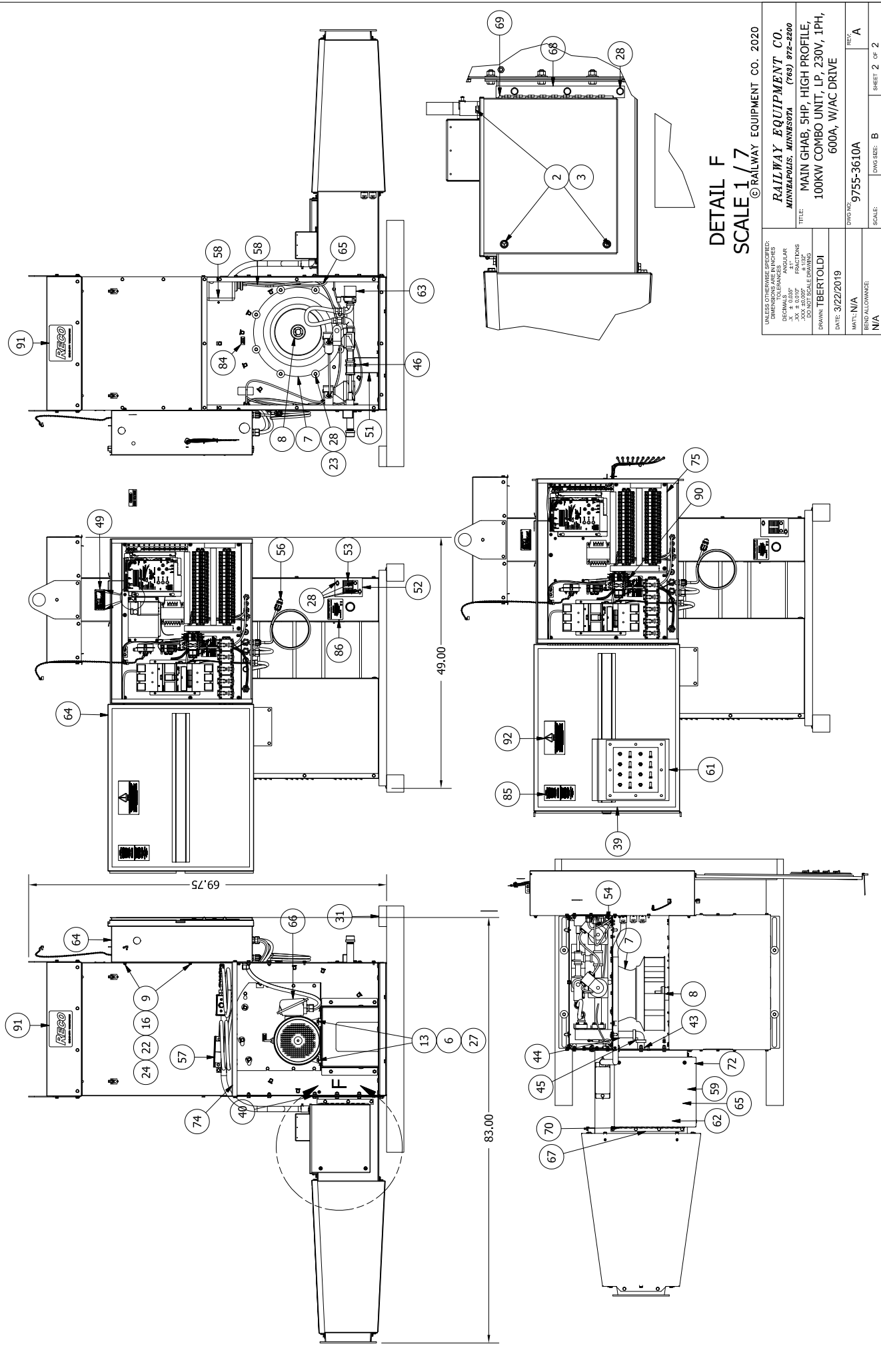

DETAIL F
SCALE 1/7

UNLESS OTHERWISE SPECIFIED:
DIMENSIONS ARE IN INCHES
DECIMALS ARE TO 3 PLACES
.XX = 0.010" FRACTIONS
DO NOT SCALE DRAWINGS
DRAWN: TBERTOLDI
DATE: 3/22/2019

© RAILWAY EQUIPMENT CO. 2020

RAILWAY EQUIPMENT CO.
MINNEAPOLIS, MINNESOTA (763) 972-2200

TITLE: MAIN GHAB, 5HP, HIGH PROFILE,
100KW COMBO UNIT, LP, 230V, 1PH,
600A, W/AC DRIVE

DWG NO: 9755-3610A
REV: A
SCALE: B
SHEET 2 OF 2

ITEM	PART NUMBER	REV	QTY	UOM	DESCRIPTION
1	1300749700	-	1	EA	CIRCUIT BREAKER, 2 POLES 50 AMP 480 VOLT INDUCTIVE
2	1300752620	-	1	EA	CIRCUIT BREAKER, 2P, 600A, 600V, 2kA, 3VA/4 FRAME
3	1300752621	-	1	EA	CIRCUIT BREAKER, 600A, 600V, 25kA, LOAD LUGS WITH COVER
4	1300752622	-	1	EA	CIRCUIT BREAKER, 600A, 600V, 25kA, LINE LUG, WITH COVER
5	14046	-	1	EA	BAG, 9 X 12 4MIL ZIPTOP
6	14172	-	1	EA	HEATER, PANEL HEATER 100W 120VAC NO THERMOSTAT 30" LEADS
7	21020	-	1	EA	CONNECTOR, HOUSING, 2 POS
8	21021	-	1	EA	CONNECTOR, HOUSING, 3 POS 18GA
9	21023	-	1	EA	STRAIN RELIEF, 3 POS
10	21212	-	1	EA	CONNECTOR, HOUSING, 3 POS 18GA
11	21201	-	1	EA	RELAY, SOCKET 14 PIN
12	21202	-	1	EA	RELAY, BAILE HOLIDOWN
13	28029	-	1	EA	TERMINAL ASSY, 1 X 12 POS
14	28077	-	1	EA	GROMMET, .25 I.D., 9/16 O.D BLACK
15	28090	-	1	EA	CAP, TERMINAL POST INSULATING
16	28091	-	1	EA	SHIELD, TERMINAL POST INSULATE
17	28104	-	50	IN	DIN MOUNTING RAIL 35MM
18	2831211116	-	2	EA	SCREW, #6-32 X 1 PAN SLT
19	2831311106	-	12	EA	SCREW, #8-32 X 3/8 PAN SLT
20	2831411106	-	42	EA	SCREW, #10-32 X 3/8 PAN SLT
21	2831411110	-	3	EA	SCREW, #10-32 X 5/8 PAN SLT
22	2831411112	-	4	EA	SCREW, #10-32 X 3/4 PAN SLT
23	2831651120	-	1	EA	BOLT, 5/16-18 X 1-1/4 HEX HEAD
24	2832-4301	-	2	EA	NUT, #10-32 KEPS
25	2832-6101	-	1	EA	NUT, 5/16-18 HEX
26	2832-6301	-	2	EA	NUT, #6-32 KEPS
27	2833-4110	-	8	EA	WASHER, #10 FLAT SAE
28	2833-4210	-	8	EA	WASHER, #10 SPLIT LOCK
29	2833-4310	-	4	EA	WASHER, #10 EXT. STAR
30	2833-6110	-	1	EA	WASHER, 5/16 FLAT SAE
31	2833-6210	-	1	EA	WASHER, 5/16 SPLIT LOCK
32	2833-6310	-	1	EA	WASHER, 5/16 EXT. STAR
33	29104	-	10	EA	CLAMP, DIN MOUNT END
34	32008	-	15,25	IN	EDGE GUARD, RUBBER
35	35205A	A	1	EA	BRACKET, PRESSURE SWITCH MOUNT FOR PANEL
36	4532-0205	-	1	EA	RELAY, 4PDT, 3A 24VDC WITH LED
37	51103	-	40	EA	FUSE, 30A 600V FST
38	5111-0206	-	2	EA	FUSE, 250V 2.5A
39	5122001630	-	42	EA	FUSE HOLDER, 1 POLE, 600V, 30A, DIN RAIL MOUNT, FINGER SAFE
40	51274	-	1	EA	FUSE HOLDER, INLINE 18 GA
41	51275	-	1	EA	FUSE 2A MDA 250V
42	53096	-	1	EA	PRESSURE SWITCH
43	5400490000	-	5	EA	CONTACTOR, 40A, 4P, 115V AC
44	5400497200	-	1	EA	COIL, AB, SIZE C40
45	56058	-	1	EA	CONTACTOR, 3POLE 32 AMP
46	60167	-	1	EA	TRANS, 575 MAX P-1155 300VA FITTING, 90 DEGREE, MALE, BRASS

ITEM	PART NUMBER	REV	QTY	UOM	DESCRIPTION
47	60223	-	5	IN	HEATSHRINK, TUBING 3/16 BLACK
48	6032-0111	-	3	EA	LUG, RING #10 16-14GA NYLON
49	6032-0117	-	3	EA	LUG, RING 1/4 12-10GA VINYL
50	6032-0118	-	3	EA	LUG, RING 1/4 16-14GA VINYL
51	6032-0120	-	2	EA	LUG, RING 1/4 22-18GA VINYL
52	6032-0123	-	1	EA	LUG, BUTT CONNECTOR 20-18 GA W/HEAT SHRINK SEAL
53	6032-0201	-	1	EA	LUG, BOX SLOTTED SCREW
54	6034-0111	-	3	EA	LUG, PUSH-ON F-250 22-18GA
55	6037-0207	-	1	EA	LUG, RING 5/16" 12-10 VINYL
56	6093-0100	-	15	EA	CABLE TIE, 4IN 0.10 WIDTH
57	6093-0302	-	45	IN	WIRE DUCT, COVER 1 IN
58	6100046300	-	3,75	FT	WIRE DUCT, 1" X 4" WHITE
59	61090	-	1	EA	MULTIFLTER / FILTER, 1/8" NPT, 7/16" DIA.
60	681001	-	240	IN	WIRE, 10GA BLACK 600V 105C
61	681205	-	27	IN	WIRE, 12 GA, GREEN
62	681601	-	47,5	IN	WIRE, 16GA GREEN - HOOK UP
63	681833	-	60	IN	WIRE, 18GA THINWALL WHITE 300V
64	681834	-	20	IN	WIRE, 18GA THINWALL RED 300V
65	7600001200	-	1	EA	ENCLOS FOR SCREW TERM BRG SWITCH
66	9338-0015C	C	1	EA	TRANSFORMER, CONTROL MODULE
67	9338-0320P	P	1	EA	CONTROL MODULE, GHAB W / TC / WEB PAGE ENABLE
68	9338-0325B	B	1	EA	SURE ARRESTOR ASSY, 240V 1PH
69	9338-2202B	B	1	EA	GHAB COMB BOARD ASSY WITHOUT XBBE RADIO
70	9508-0001A	A	1	EA	GHAB MODULE TO AAR HARNESS
71	9538-0029B	B	1	EA	ASSY, AIR FLOW WIRES HIGH IN PANEL
72	9538-0163A	-	1	EA	DRIVE, AC, MITSUBISHI, 7.5 HP, 240V 1PH INPUT, 240V 3 PH OUTPUT, WIRED AND PROGRAMMED
73	9538-5043A	A	1	EA	SPACER, GHAB, CONTROL MODULE, SHP, HIGH AND LOW PROFILE
74	9755-0182A	A	1	EA	PANEL, GHAB CONTROL, COMBO UNIT, 3/5HP W/100KW ELECTRIC DUCT
75	9755-5044A	A	1	EA	SPACER, BREAKER, GHAB COMBO UNIT, SHP, 240V, 1PH, 600A, FOR 100KW DUCT
76	R8039-0810A	A	1	EA	LABEL, AAR TERMINAL

REV	ECO #	DESCRIPTION	DATE	BY
A	22-069	NEW PART	08/30/2022	AK

© RAILWAY EQUIPMENT CO. 2020

RAILWAY EQUIPMENT CO.
MINNEAPOLIS, MINNESOTA (763) 872-2200

TITLE: ASSY, GHAB, COMBO UNIT, CONTROL PANEL, SHP, 230V, 1PH, W/AC DRIVE AND 100KW DUCT

DATE: 08/31/2022

DRAWN: AK

CHECKED: N/A

SCALE: 1/6

DWG NO: 9755-0181A

REV: A

SHEET 1 OF 3

NOTE: HEATER PAD (P/N 14172) MUST BE PLACED DIRECTLY UNDER AC DRIVE AND SO IT DOES NOT INTERFERE WITH DRIVE MOUNTING HOLES

FRONT VIEW

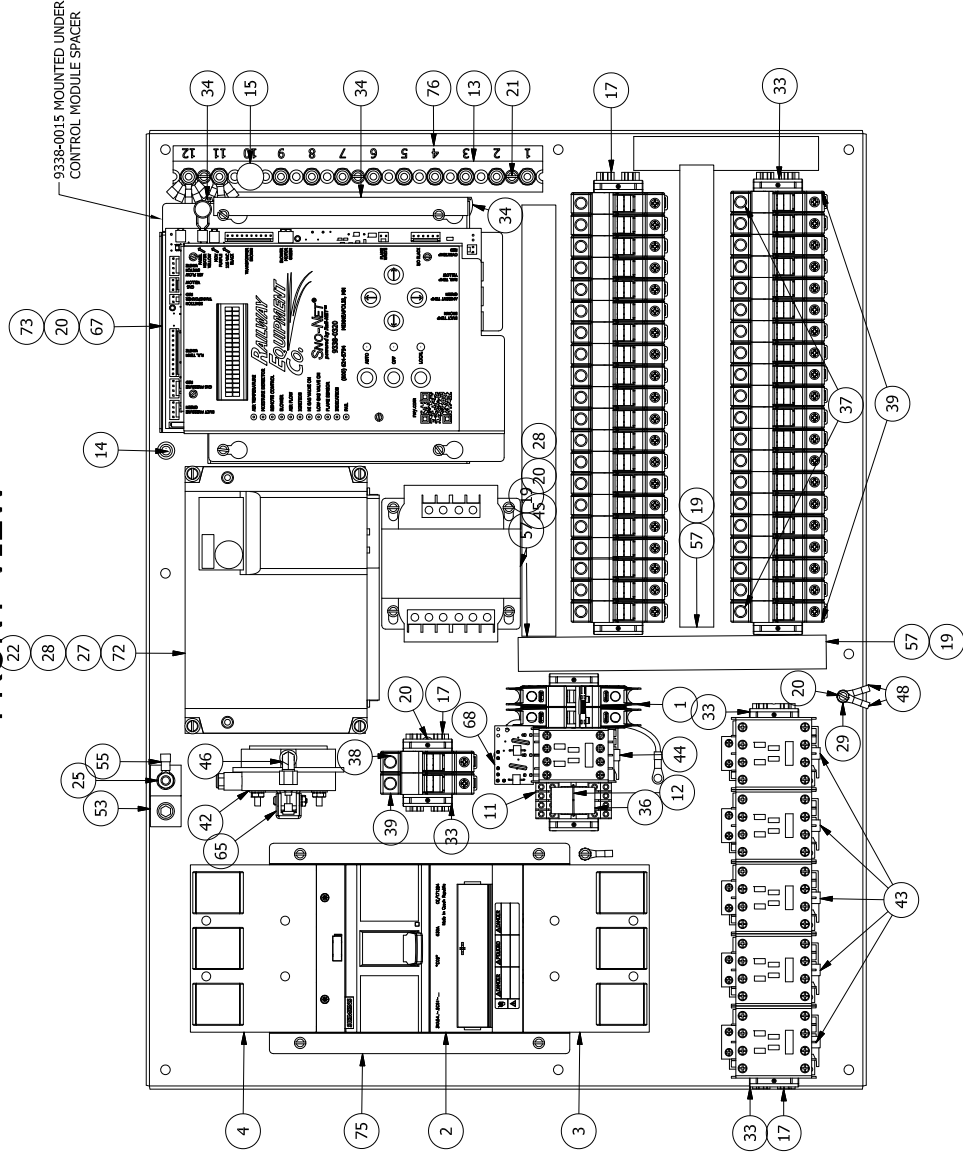

BACK VIEW

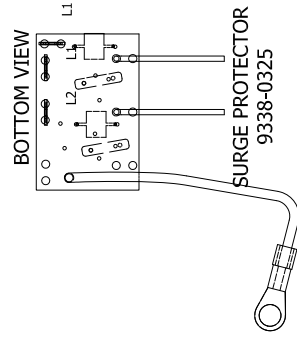
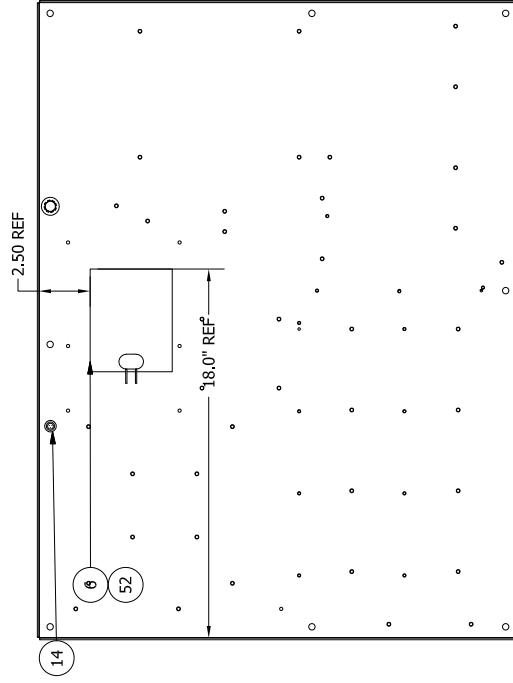

UNLESS OTHERWISE SPECIFIED: DIMENSIONS ARE IN INCHES DECIMALS AND FRACTIONS UNLESS OTHERWISE SPECIFIED DIMENSIONS ARE IN MILLIMETERS UNLESS OTHERWISE SPECIFIED DIMENSIONS ARE IN MILLIMETERS DO NOT SCALE DRAWINGS		© RAILWAY EQUIPMENT CO. 2020
DRAWN: AK		RAILWAY EQUIPMENT CO. MINNEAPOLIS, MINNESOTA (763) 972-2800
DATE: 08/31/2022		TITLE: ASSY, GHAB, COMBO UNIT, CONTROL PANEL, 5HP, 230V, 1PH, W/AC DRIVE AND 100KW DUCT
MATERIAL: N/A		DWG NO.: 9755-0181A
REVISION: N/A		SCALE: 1/6
REVISION ALLOWANCE: N/A		DWG SIZE: B
		SHEET 2 OF 3

MITSUBISHI DRIVE

- NOTE:
 MITSUBISHI DRIVE SETTINGS:
 P1 = 60 MAX HZ
 P2 = 55 MIN HZ
 P3 = 60 MOTOR BASE HZ
 P4 = 60 HZ RUNNING SPEED FOR 2HP AND HP, 58HZ FOR 5 HP
 P7 = 20 SECOND RAMP
 P77 = 2 CHANGE PARAMETERS WHILE RUNNING
 P79 = 3 EXTERNAL/PU
 P192 = 0 RELAY INDICATION INVERTER RUNNING
 P872 = 0 FOR 5HP ONLY

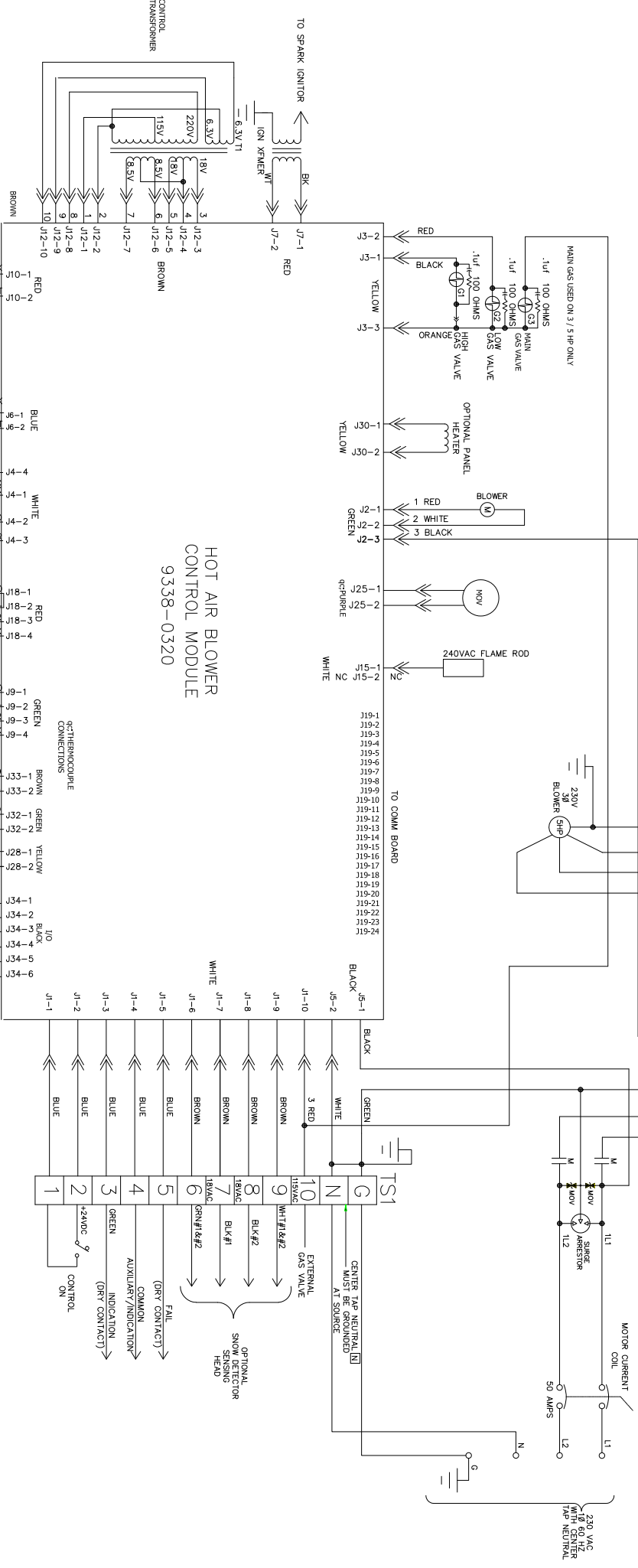

© RAILWAY EQUIPMENT CO. 2020

UNLESS OTHERWISE SPECIFIED:	
DIMENSIONS ARE IN INCHES	
DECIMALS ARE ANGULAR	
FRACTIONS ARE ANGULAR	
DO NOT SCALE DRAWING	
DRAWN: AK	TITLE:
DATE: 08/31/2022	MITSUBISHI AC DRIVE, 5HP-240V, 1PH
WHT: NA	SCHEMATIC / CONNECTION DIAGRAM
DESIGN: NA	DATE:
SCALE: 1" = 1"	SHEET: 3 OF 3

REV	ECO	DESCRIPTION	DATE	BY
A	-	NEW ASSEMBLY	02/20/2023	AK

PARTS LIST					PARTS LIST						
ITEM	PART NUMBER	REV	UOM	QTY	DESCRIPTION	ITEM	PART NUMBER	REV	UOM	QTY	DESCRIPTION
1	16003	-	EA	.33	RTV SILICONE CLEAR 10 OZ TUBE	54	95056C	C	EA	1	BRACKET, GAS SUPPORT INSIDE
2	2600973500	-	EA	4	BOLT, 5/16 - 18 X 1, WASHER HEAD, ZINC	55	95059C	C	EA	1	COVER PLATE, GAS LINE 5 & 3PH
3	2600975600	-	EA	4	NUT, 5/16-18, CLIP ON, STEEL, BLACK PHOSPHATE	56	95059A	A	EA	1	COVER, MUFFLER GHAB
4	2600979300	-	EA	11	NUT, 1/4-20, CLIP ON, STEEL, BLACK PHOSPHATE	57	9508-0038A	A	EA	1	ASSY, GAS SENSOR EXT CABLE
5	2600981850	-	EA	4	NUT, 1/4-20, CAGE, ZINC	58	9508-0365E	E	EA	1	OVERTEMP, ASSY, HI/OVER TEMP SENSOR, W COPPER ROD, 15 FT, TIE DUCT MOUNT
6	2600981900	-	EA	4	NUT, 3/8-16, CAGE, ZINC	59	9508-0404A	A	EA	1	RAIL TEMP SNKR T/C MAGNETIC
7	26016A	A	EA	1	BLOWER, INLET CONE, 1350, 90%, 5HP	60	9508-0415B	B	EA	1	ASSY, WIRED IGNITION XFMR
8	26030B	B	EA	1	ASSY, BLOWER WHEEL, 5HP, 7 FINS	61	9508-0433A	A	EA	1	ASSY, FLAME WIRE
9	28035	-	EA	8	MOUNT, RUBBER, M/M 1/4-20	62	9508-0496B	B	EA	1	DUCT, FLAME, COVER, 10" BOLT PATTERN
10	2831211104	-	EA	4	SCREW, #6-32 X 1/4 PAN SLT	63	9508-0800A	A	EA	1	ASSY, GAS LINE ACCESSORIES 3/5HP
11	2831411112	-	EA	1	SCREW, #10-32 X 3/4 PAN SLT	64	9528-0027E	E	EA	1	ASSY, WIRED MOTOR, 5HP/460V/3PH
12	2831651110	-	EA	2	BOLT, 1/4-20 X 5/8 HEX HEAD	65	9528-0038A	A	EA	1	GASKET KIT, 9X9 5HP DUCTWORK
13	2831851116	-	EA	18	BOLT, 3/8-16 X 1 HEX CAP	66	9528-0074D	D	EA	1	GHAB, GAS PIPING W/ PRESSURE SENSOR
14	2832-3301	-	EA	4	NUT, 1/4-20 KEPS	67	9528-0135C	C	EA	1	ENCLOSURE, GHAB W/ 922 OUTPUT
15	2832-4101	-	EA	2	NUT, #10-32 HEX	68	9528-0237D	D	EA	1	ASSEMBLY, IGNITION WIRE
16	2832-5101	-	EA	17	NUT, 1/4-20 HEX	69	95348A	A	EA	1	FLAME DUCT, BURNER ACCESS COVER, TOP
17	2832-5801	-	EA	17	NUT, 1/4-20 CENTERLOCK	70	9538-0048A	A	EA	1	COVER, HINGE PLATE
18	2832-8101	-	EA	14	NUT, #6-32 X 1/4 HEX	71	9538-0137A	A	EA	1	FLAME DUCT, BURNER ACCESS COVER, SIDE
19	2832210108	-	EA	4	NUT, #6-32 X 1/4 HEX	72	9538-0138A	A	EA	1	FLAME DUCT, BURNER ACCESS COVER, HINGE
20	2833-4210	-	EA	1	WASHER, #10 SPLIT LOCK	73	9538-0139A	A	EA	1	PIN, 3/16 OD, SS, 9.5"
21	2833-4310	-	EA	2	WASHER, #10 EXT. STAR	74	9538-0140A	A	EA	1	FLAME DUCT, BURNER ACCESS COVER, HINGE
22	2833-5110	-	EA	19	WASHER, 1/4 FLAT	75	9538-0141A	A	EA	1	PIN, 3/16 OD, SS, 12.5"
23	2833-5119	-	EA	8	WASHER, 1/4 X 1.5 FENDER	76	9538-0142A	A	EA	1	FLAME DUCT, BURNER ACCESS COVER, TOP
24	2833-5211	-	EA	17	WASHER, 1/4 SPLIT LOCK	77	9538-0161A	A	EA	1	COVER
25	2833-8040	-	EA	4	RIVET, BUTTON HEAD PLATED STL	78	9538-1000A	A	EA	1	ASSY, 3/5HP, HIGH PROFILE, PRESSURE SENSOR BLOWER ASSEMBLY
26	2833-8110	-	EA	6	WASHER, 3/8 FLAT	79	9538-1000A	A	EA	1	GHAB, HIGH PROFILE, 3/5HP, SHELL ASSEMBLY
27	2833-8210	-	EA	18	WASHER, 3/8 SPLIT LOCK	80	9538-1000A	A	EA	1	ASSY, GHAB, COMBO UNIT, CONTROL PANEL, 5HP, 460V, 3PH, W/100KW DUCT
28	29051	-	EA	78	BOLT, 1/4-20 X 1/2 WITH 1/2 HD	81	9755-0183A	A	EA	1	ASSY, GHAB, COMBO UNIT, 3/5HP, 100KW, 240V, W/WELDED BAG FLANGES
29	32002	-	EA	1	INSULATION, FIBERGLASS	82	9755-1131A	A	EA	4	FLAME DUCT, GHAB COMBO UNIT, 3/5HP, 100KW, TERMINAL BLOCK MOUNTING BRACKET
30	32005	-	EA	12	EDGE GUARD, RUBBER	83	9755-1132A	A	EA	1	FLAME DUCT, GHAB COMBO UNIT, 3/5HP, 100KW, 240V, W/WELDED BAG FLANGES
31	32025	-	EA	.333	2" X 4" X 12' FOR PALLETS	84	9755-1133A	A	EA	1	INSULATION COVER, TOP
32	5500083700	-	EA	2	SWITCH, TEMP 150V OPEN/20V CLOSE	85	9755-1136B	B	EA	1	FLAME DUCT, GHAB COMBO UNIT, 3/5 HP, 100KW, INSULATION COVER, TOP
33	5600225712	-	EA	4	TERMINAL BLOCK, 12 POLE, 60A, 600V, 6AWG	86	9755-1137B	B	EA	1	ACCESS COVER
34	60002	-	EA	1	3/8 ROMEX BRIDGEPORT# 650-DC2	87	9809-1051	-	EA	1	RRAMAC LIFETIME ASSET REGISTRATION FEE
35	60062	-	EA	13	CONDUIT, FLEXIBLE, 1" STEEL	88	R8039-0816A	A	EA	2	LABEL, FAN ROTATION
36	60076	-	EA	1	CONDUIT, FLEXIBLE METAL FITTING, 90 DEGREE	89	R8039-0830A	A	EA	1	LABEL, GHAB WARNINGS
37	60162	-	EA	2	ELBOW, STEEL, ZINC COATED, 1" TRADE SIZE, FEMALE	90	R8039-0951A	A	EA	1	LABEL, GHAB CONNECTION/BULKHEAD
38	60169	-	EA	12	TY-RAP 0.30 X 8	91	R8039-0980A	A	EA	1	LABEL, DANGER HIGH VOLTAGE
39	60185A	A	EA	8	GASKET, 0.25 X 0.75 ADHESIVE BACK	92	R9330-0021B	B	EA	1	LABEL, TERM POST SNO NET
40	60195	-	EA	6	GASKET, .25 X 1.0 ADHESIVE BK	93	R9530-7235A	A	EA	2	MANUAL, GHAB - 922
41	60262	-	EA	2	CONDUIT, FLEXIBLE METAL FITTING, STRAIGHT, STEEL, 1" TRADE SIZE, FEMALE CONDUIT X 1" MALE NPT	94	R9538-7235A	A	EA	1	LABEL, ID PLATE, GHAB, HYBRID
42	60362	-	EA	4	CONDUIT, CLAMPING HANGER, FOR 1" TRADE SIZE, 1-5/16" ID	95	R960031B	B	EA	2	LABEL, HAB ENCLOSURE
43	6093-0100	-	EA	9	CABLE TIE, 4IN 0.10 WIDTH	96	R99001A	A	EA	1	LABEL, CAUTION LABEL INSIDE GHAB ENCLOSURES
44	6093-0102	-	EA	12	TY-RAP						
45	61032	-	EA	1	NIPPLE, 1 X 3 IN SCH 40 BLACK						
46	61047	-	EA	1	NIPPLE, 1 X 5 IN SCH 40 BLACK						
47	61058	-	EA	1	ELBOW, 1IN SCH 40 BLACK						
48	61070	-	EA	1	U-BOLT, MRO BOLT #05						
49	61191	-	EA	7.75	GASKET, HI TEMP SILICONE, 0.5W X 0.25 H, WITH ADHESIVE BACK						
50	681122	-	EA	400	WIRE, 12GA, HIGH TEMP						
51	8039-0806A	A	EA	1	LABEL, HIGH VOLTAGE						
52	8040-0952E	E	EA	1	NAMEPLATE, 952/953 GHAB						
53	91504F	F	EA	20	HEATER, 5KW 480V						

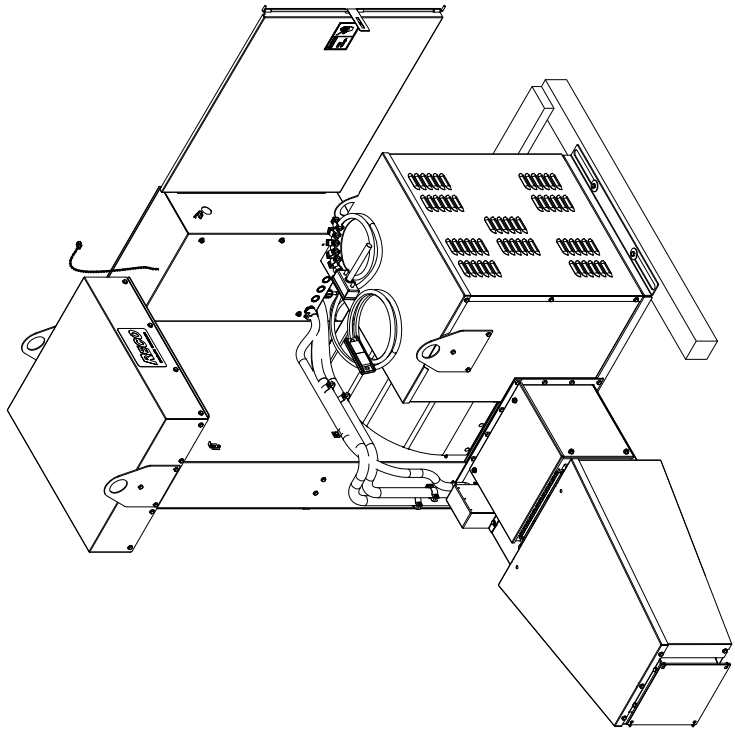

UNLESS OTHERWISE SPECIFIED:
DIMENSIONS ARE IN INCHES
DECIMALS TO THIRDS PLACE
.XX, .X, 0.010" FRACTIONS
DO NOT SCALE DRAWINGS

DATE: 02/20/2023
MFG: N/A
REV: A

SCALE: 1/16" = 1" DRAWING NO: 9755-3400A SHEET 1 OF 2

© RAILWAY EQUIPMENT CO. 2023

RAILWAY EQUIPMENT CO.
MINNEAPOLIS, MINNESOTA (763) 972-2200

TITLE: MAIN GHAB, 5HP, HIGH PROFILE, 100KW COMBO UNIT, LP, 460V, 3PH, 200A

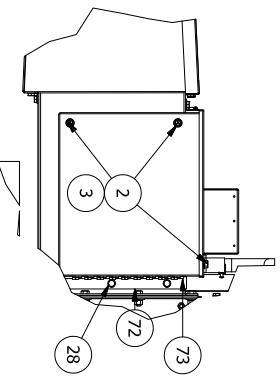
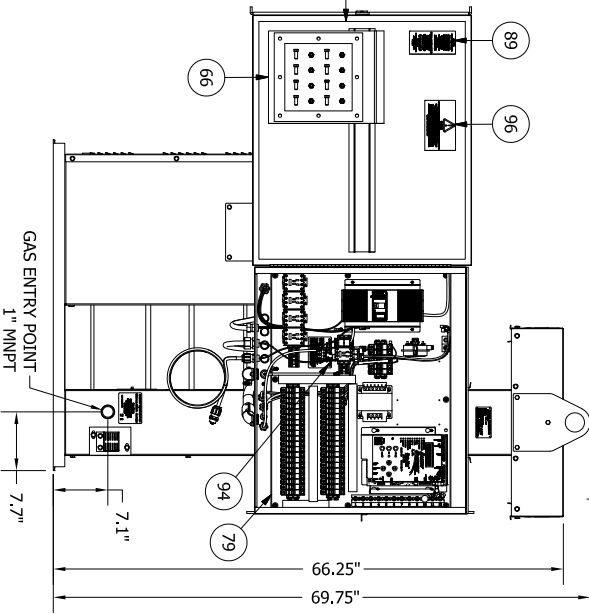
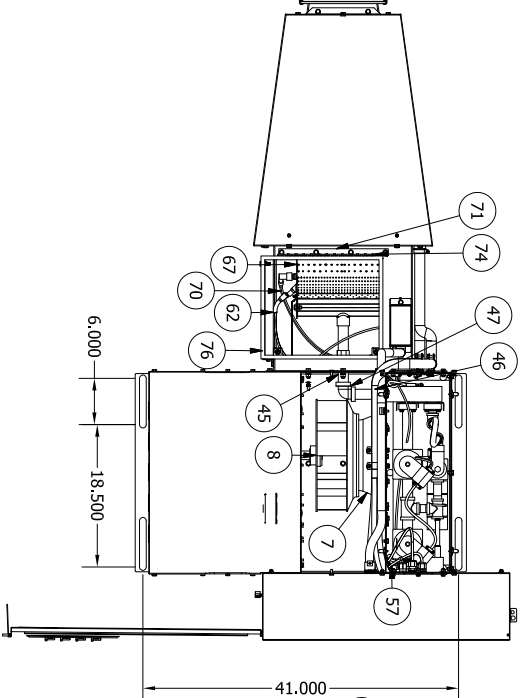
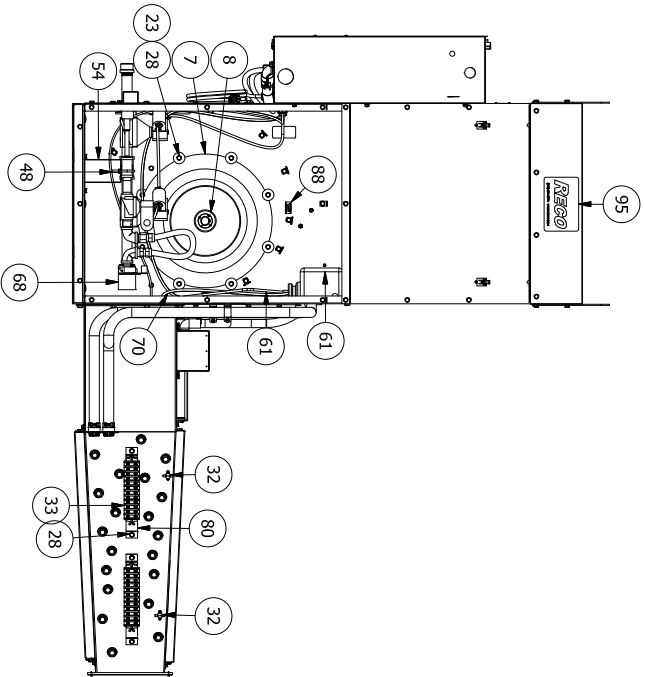
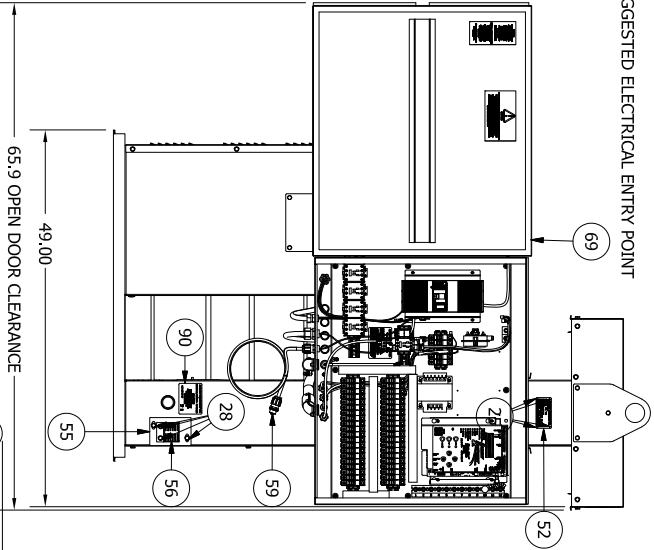
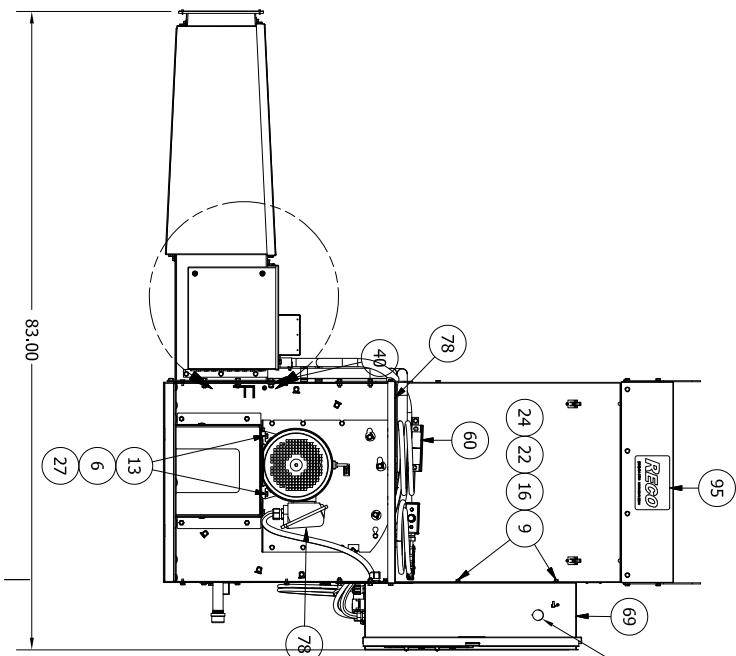

DETAIL F
SCALE 1 / 10

© RAILWAY EQUIPMENT CO. 2023

UNLESS OTHERWISE SPECIFIED: DIMENSIONS ARE IN INCHES DECIMALS .0005" ANGULAR X.XX 4 0.01" FRACTIONS X/16 0.0156" DECIMALS X/32 0.0156" DECIMALS DRAWING AK		RAILWAY EQUIPMENT CO. MINNETONKA, MINNESOTA (763) 972-4200 TITLE: MAIN GHAB, SHP, HIGH PROFILE, 100KW COMBO UNIT, LP, 460V, 3PH, 200A	
DATE: 02/20/2023	DWG NO: 9735-3400A	REV: A	SCALE: 2 OF 2
WHT: N/A	DWG SER: B	SHEET 2 OF 2	
TEND: A/CLEARANCE			

REVISION HISTORY			
REV	ECO #	DESCRIPTION	DATE
A	-	NEW PART	01/24/2023
BY	AK		

PARTS LIST				PARTS LIST			
ITEM	PART NUMBER	REV	QTY	UOM	DESCRIPTION	ITEM	PART NUMBER
1	1300749700	-	1	EA	CIRCUIT BREAKER, 2 POLES 50 AMP 480 VOLT INDUCTIVE	40	5400490000
2	1300751200	-	1	EA	CIRCUIT BREAKER, 3 POLE, 200A, 600V, 25KA, I FRAME	41	5400490300
3	1300751201	-	1	EA	CIRCUIT BREAKER LUG KIT, FRAME I, LOAD SIDE, 3 LUGS INCLUDED	42	56058
4	1300751202	-	1	EA	CIRCUIT BREAKER LUG KIT, FRAME I, LINE SIDE, 3 LUGS INCLUDED	43	60167
5	1300751203	-	1	EA	CIRCUIT BREAKER TERMINAL COVER, FRAME I, 2 COVERS INCLUDED	44	6032-0111
6	14046	-	1	EA	BAG, 9 X 12 4MIL ZIPTOP	45	6032-0117
7	21020	-	1	EA	CONNECTOR, HOUSING, 2 POS	46	6032-0118
8	21021	-	1	EA	STRAIN RELIEF, 2 POS	47	6032-0120
9	21023	-	1	EA	STRAIN RELIEF, 3 POS	48	6032-0201
10	21212	-	1	EA	CONNECTOR, HOUSING, 3 POS 18GA	49	6034-0111
11	21701	-	1	EA	RELAY, SOCKET 14 PIN	50	6037-0207
12	21702	-	1	EA	RELAY, BALE HOLDOWN	51	6093-0100
13	28029	-	1	EA	TERMINAL ASSY, 1 X 12 POS	52	6093-0302
14	28090	-	1	EA	CAP, TERMINAL POST INSULATING	53	6100046300
15	28091	-	1	EA	SHIELD, TERMINAL POST INSULATE	54	61090
16	28104	-	50	IN	DIN MOUNTING RAIL 35MM	55	681001
17	283121116	-	2	EA	SCREW, #6-32 X 1 PAN SLT	56	681205
18	283131106	-	12	EA	SCREW, #8-32 X 3/8 PAN SLT	57	681601
19	283141106	-	42	EA	SCREW, #10-32 X 3/8 PAN SLT	58	681833
20	283141110	-	3	EA	SCREW, #10-32 X 5/8 PAN SLT	59	681834
21	2831651120	-	1	EA	BOLT, 5/16-18 X 1-1/4 HEX HEAD	60	7600001200
22	2832-4301	-	2	EA	NUT, #10-32 KEPS	61	9338-0015C
23	2832-6101	-	1	EA	NUT, 5/16-18 HEX	62	9338-0320P
24	2832-6301	-	2	EA	NUT, #6-32 KEPS	63	9338-0326B
25	2833-4110	-	4	EA	WASHER, #10 FLAT SAE	64	9508-0001A
26	2833-4210	-	8	EA	WASHER, #10 SPLIT LOCK	65	9538-0029B
27	2833-4310	-	4	EA	WASHER, #10 EXT. STAR	66	9538-5043A
28	2833-6110	-	1	EA	WASHER, 5/16 FLAT SAE	67	9755-0182A
29	2833-6210	-	1	EA	WASHER, 5/16 SPLIT LOCK	68	9755-5043A
30	2833-6310	-	1	EA	WASHER, 5/16 EXT. STAR	69	R8039-0810A
31	29104	-	10	EA	CLAMP, DIN MOUNT END		
32	32008	-	15.25	IN	EDGE GUARD, RUBBER		
33	35205A	A	1	EA	BRACKET, PRESSURE SWITCH MOUNT FOR PANEL		
34	4532-0205	-	1	EA	RELAY, 4PDT, 3A 24VDC WITH LED		
35	51103	-	40	EA	FUSE, 30A 600V FST		
36	5111-0601	-	2	EA	FUSE, 500V 1AMP SLO-BLO		
37	5122001630	-	42	EA	FUSE HOLDER, 1 POLE, 600V, 30A, DIN RAIL MOUNT, FINGER SAFE		
38	53096	-	1	EA	PRESSURE SWITCH		
39	5400489800	-	1	EA	CONTACTOR, 4POLE 32 AMP 115V COIL 9 AMP INDUCTIVE		

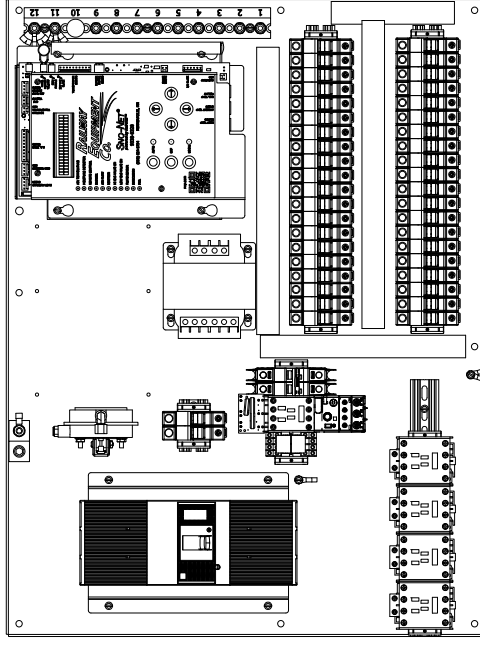

© RAILWAY EQUIPMENT CO. 2020	
UNLESS OTHERWISE SPECIFIED: DIMENSIONS ARE IN INCHES DECIMALS TO THIRDS .XX, 4.3125" FRACTIONS DO NOT SCALE DRAWING	
DRAWN: AK	
DATE: 08/31/2022	REV: A
MATERIAL: N/A	SCALE: 1/6
ISSUE ALLOWANCE: N/A	DWG SIZE: B
SHEET 1 OF 3	

RAILWAY EQUIPMENT CO. MINNEAPOLIS, MINNESOTA (763) 872-2800	
TITLE: ASSY, GHAB, COMBO UNIT, CONTROL PANEL, 5HP, 460V, 3PH, W/100KW DUCT	
DWG NO: 9755-0183A	REV: A
SCALE: 1/6	DWG SIZE: B
SHEET 1 OF 3	

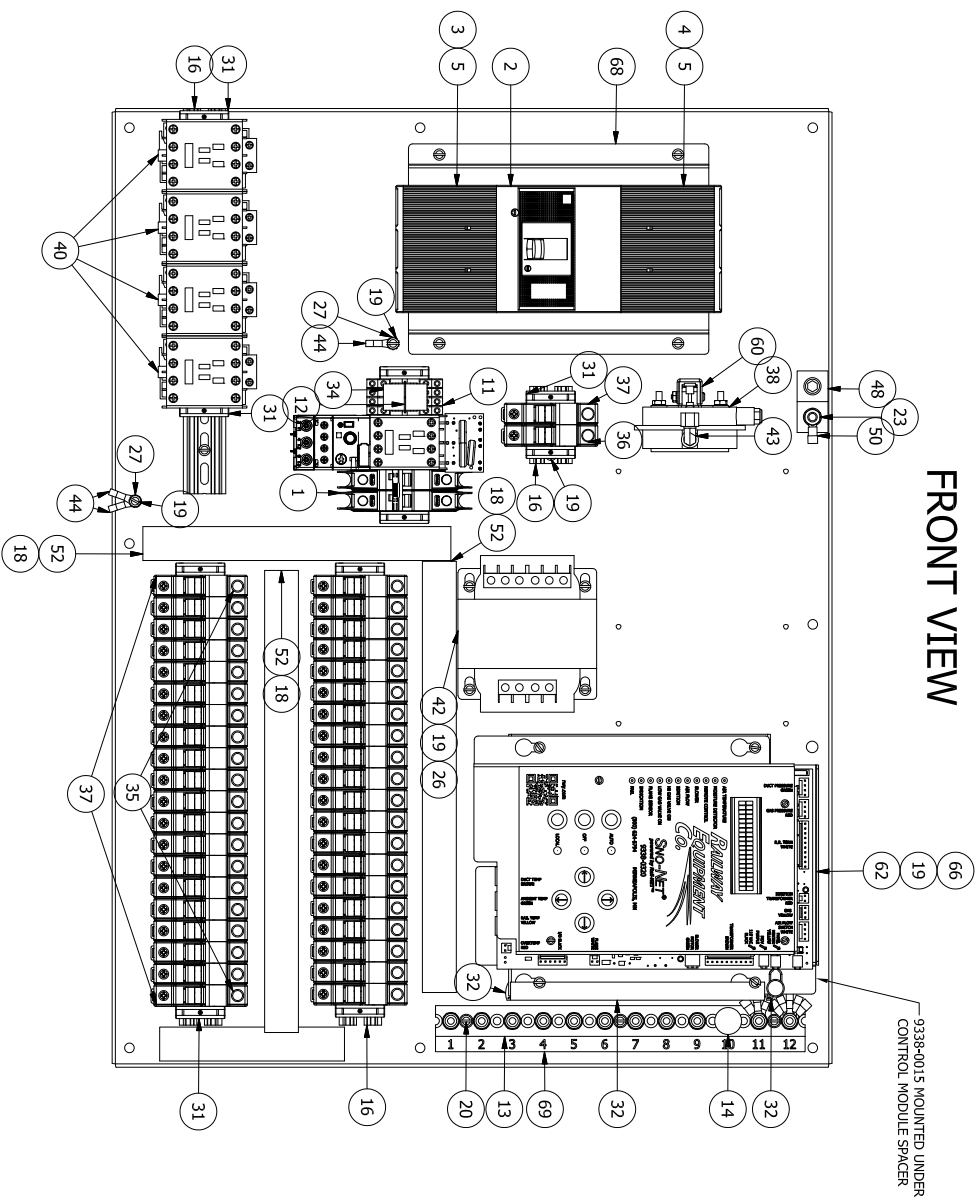

UNLESS OTHERWISE SPECIFIED:		DIMENSIONS ARE IN INCHES	
DECIMALS	ANGULAR	FRACCTIONS	DO NOT SCALE DRAWING
.XX, 4, .010"			
DATE: 08/31/2022	WNT: N/A	DWG NO: 9755-0183A	REV: A
DRAWN: AK		TEND: T/ALVINCE	
TITLE: RAILWAY EQUIPMENT CO. MINNEAPOLIS, MINNESOTA (763) 872-4200		SCALE: 1/4"	DWG. SER: B
ASSY, GHAB, COMBO UNIT, CONTROL PANEL, 5HP, 460V, 3PH, W/100KW DUCT		SHEET 2 OF 3	
© RAILWAY EQUIPMENT CO. 2020			

MITSUBISHI DRIVE

NOTE:
MITSUBISHI DRIVE SETTINGS:

- P1 = 60 MAX HZ
- P2 = 55 MIN HZ
- P3 = 60 MOTOR BASE HZ
- P4 = 60 HZ RUNNING SPEED FOR 2HP AND HP, 58HZ FOR 5 HP
- P7 = 20 SECOND RAMP
- P9 = MOTOR OVERLOAD CURRENT 2HP=6, 3HP=8.7, 5HP=13.5
- P77 = 2 CHANGE PARAMETERS WHILE RUNNING
- P79 = 3 EXTERNAL/PU
- P192 = 0 RELAY INDICATION INVERTER RUNNING
- P872 = 0 FOR 5HP ONLY

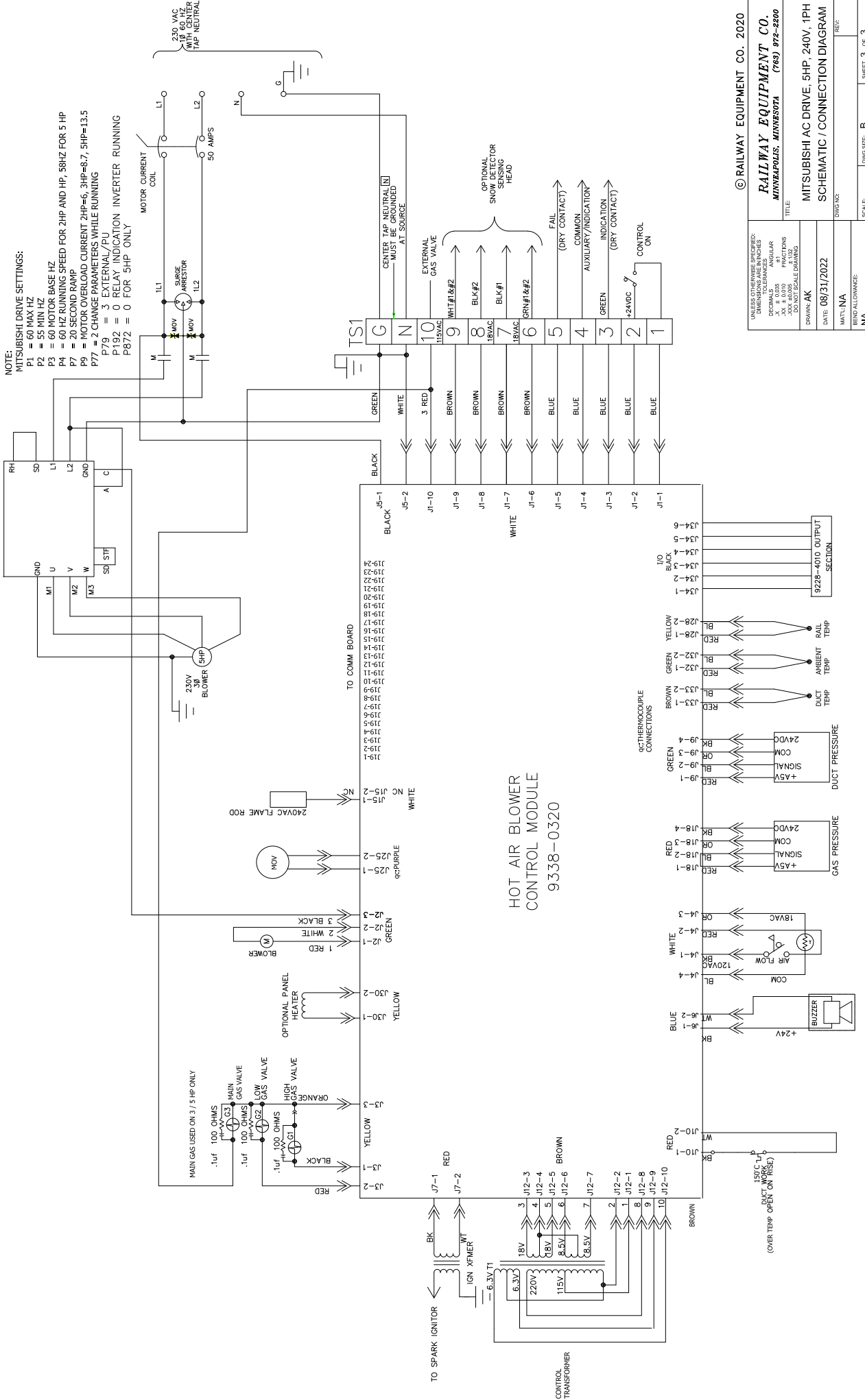

HOT AIR BLOWER CONTROL MODULE 9338-0320

© RAILWAY EQUIPMENT CO. 2020
RAILWAY EQUIPMENT CO.
 MINNEAPOLIS, MINNESOTA (763) 972-2200
 TITLE: MITSUBISHI AC DRIVE, 5HP, 240V, 1PH
 SCHEMATIC / CONNECTION DIAGRAM
 DRAWN: AK
 DATE: 08/31/2022
 REVISION: NA
 SCALE: DRAWING: B SHEET 3 OF 3

UNLESS OTHERWISE SPECIFIED:
 DIMENSIONS ARE IN INCHES
 DECIMALS ARE TO BE ROUNDED UP
 FRACTIONS ARE TO BE ROUNDED DOWN
 DO NOT SCALE DRAWINGS

ITEM PART NUMBER	REV	QTY	UOM	DESCRIPTION	ITEM PART NUMBER	REV	QTY	UOM	DESCRIPTION	
1	12425	-	1080 IN	TAPE ROLL 2 INCH WIDE HEAVY BAG, BURLAP 10" X 14" 100Z	13	927237	A	2	EA	COVER PLATE, TEMP SENSOR
2	14150	-	1 EA	WIRE BURLAP BAG CLOSING TIES 6"	14	927248	A	4	EA	RAIL CLIP, THE DUCT
3	14151	-	1 EA	BOLT, 3/4-10 X 1-1/2 HEX SS	15	927355	B	2	EA	THE PLATE 136# E-CLIP-PAD TYPE
4	28121	-	8 EA	BOLT, 3/8-16 X 1 HEX HEAD, SS	16	927366	A	4	EA	E-CLIP INSULATOR
5	283185114	-	4 EA	BOLT, 1/2-13 X 1.25 HEX SS	17	927367	B	2	EA	PAD FOR E-CLIP RUBBER 136# TIE
6	2831951121	-	16 EA	NUT, 1/2-13 CENTERLOCK GRADE 5 ZINC	18	927602	A	2	EA	COVER, POINT/TRACK NOZZLE
7	2831951124	-	12 EA	BOLT, 1/2-13 X 1-1/2 HEX HEAD	19	927603	A	2	EA	COVER, OUTSIDE TRACK NOZZLE
8	2833-9901	-	12 EA	WASHER, 3/8 SPLIT LOCK	20	952572A	A	2	EA	COVER PLATE WITH LIFTING LUG 6-HOLE PATTERN
9	2833-8210	-	4 EA	WASHER, 3/4 SPLIT LOCK	21	9525738	B	1	EA	ASSY, THE DUCT QUICK CHANGE, 6-HOLE FLANGE
10	2833-9009	-	8 EA	WASHER, M12 SPLIT-LOCK	22	952574A	A	2	EA	GASKET, THE DUCT 6-HOLE PATTERN
11	2833-9020	-	16 EA	TY-RAP, 0.30 X 8	23	R8039-0904D	D	2	EA	CAUTION LABEL, THE DUCT 136#
12	60169	-	2 EA		24	R8039-0914D	D	1	EA	TAG, ACCESS PARTS FOR THE DUCT136#

PARTS LIST

PARTS LIST

REV	ECO #	DESCRIPTION	DATE	BY
A	17-0017	NEW PART	1/22/2018	JT

NOTE: PLACE THE FOLLOWING PARTS INTO BURLAP BAG, SEAL AND LABEL.

Qty	Description	P/N
4	Rail Clip (BUNDLED)	927248
2	Pod for E-clip #136 tie	927367
4	E-clip insulator	927366

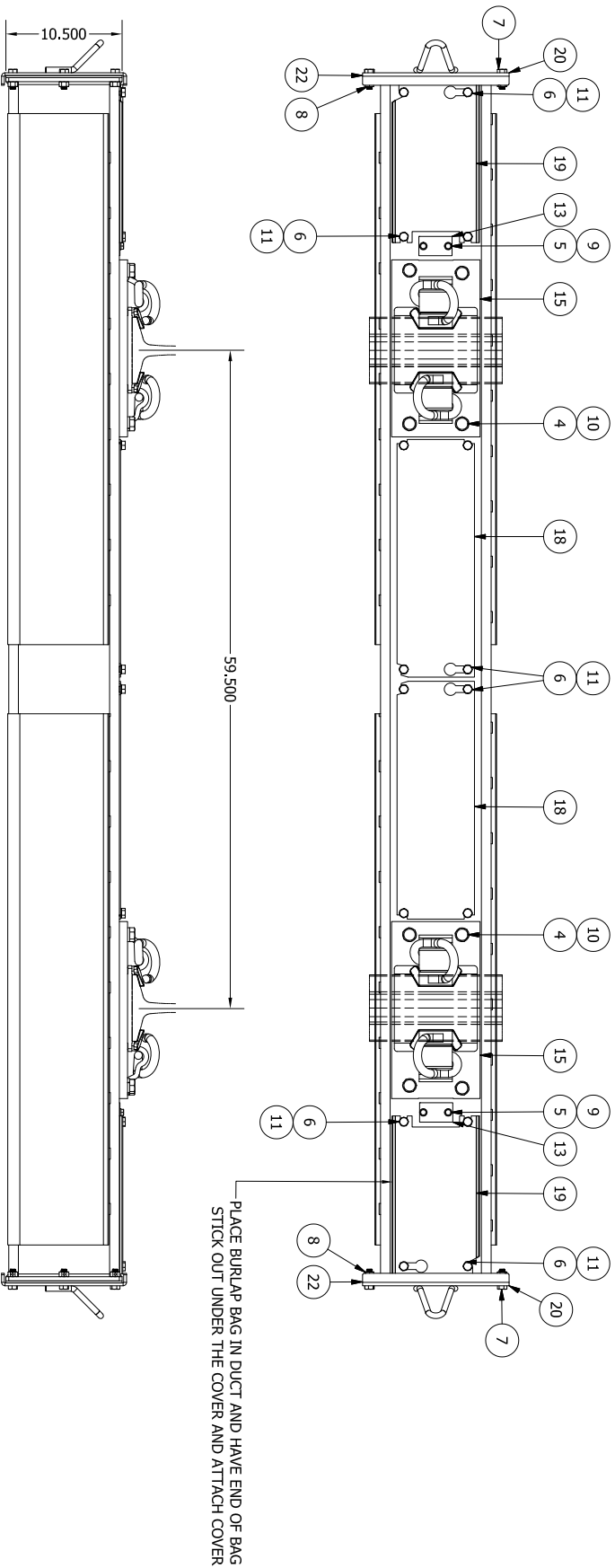

© RAILWAY EQUIPMENT CO. 2020

UNLESS OTHERWISE SPECIFIED:		DIMENSIONS ARE IN INCHES	
DECIMALS	ANGULAR	FRACCTIONS	SCALE
.XX, .X, .010"		1/16", 1/8", 3/16", 1/4", 3/8", 1/2", 5/8", 3/4", 7/8", 1"	AS SHOWN
DRAWN: TBERTOLDI			
DATE: 1/24/2019			
WRT: N/A			
TRNG: N/A			
SCALE: 1/10	DWG. SIZE: B	SHEET 1 OF 1	REV: A

RAILWAY EQUIPMENT CO.
 MINNEAPOLIS, MINNESOTA (763) 872-4200

TITLE: THE DUCT, 136# QUICK CHANGE, 6-HOLE FLANGE

REV	ECO #	DESCRIPTION	DATE	BY
A	17-0017	NEW PART	9/13/2018	TB

PARTS LIST				PARTS LIST							
ITEM	PART NUMBER	REV	QTY	UOM	DESCRIPTION	ITEM	PART NUMBER	REV	QTY	UOM	DESCRIPTION
1	12425	-	1080	IN	TAPE ROLL 2 INCH WIDE HEAVY	14	927237	A	2	EA	COVER PLATE, TEMP SENSOR
2	14150	-	1	EA	BAG, BURLAP 10" X 14" 100Z	15	927248	A	4	EA	RAIL CLIP, TIE DUCT
3	14151	-	1	EA	WIRE BURLAP BAG CLOSING TIES 6"	16	927356	B	2	EA	TIE PLATE 115# E-CLIP PAD TYPE
4	28121	-	8	EA	BOLT, 3/4-10 X 1-1/2 HEX SS	17	927366	A	4	EA	E-CLIP INSULATOR
5	2831851114	-	4	EA	BOLT, 3/8-16 X 1 HEX HEAD, SS	18	9273688	B	2	EA	PAD FOR E-CLIP RUBBER 115# TIE
6	2831951121	-	12	EA	BOLT, 1/2-13 X 1.25 HEX SS	19	927602	A	2	EA	COVER, POINT/TRACK NOZZLE
7	2831951123	-	4	EA	BOLT, 1/2-13 X 1.75 HEX SS	20	927603	A	2	EA	COVER, OUTSIDE TRACK NOZZLE
8	2831951124	-	12	EA	BOLT, 1/2-13 X 1-1/2 HEX HEAD	21	952572A	A	2	EA	COVER PLATE WITH LIFTING LUG 6-HOLE PATTERN
9	2832-9901	-	12	EA	NUT, 1/2-13 CENTERLOCK GRADE 5 ZINC	22	952573B	B	1	EA	ASSY, TIE DUCT QUICK CHANGE, 6-HOLE FLANGE
10	2833-8210	-	4	EA	WASHER, 3/8 SPLIT LOCK	23	952574A	A	2	EA	GASKET, TIE DUCT 6-HOLE PATTERN
11	2833-9009	-	8	EA	WASHER, 3/4 SPLIT LOCK	24	R8039-0905D	D	2	EA	CAUTION LABEL, TIE DUCT 115#
12	2833-9020	-	16	EA	WASHER, M12 SPLIT-LOCK	25	R8039-0915D	D	1	EA	TAG, ACCESS PARTS FOR TIE DUCT 115#
13	60169	-	2	EA	TY-RAP, 0.30 X 8						

PARTS LIST

PARTS LIST

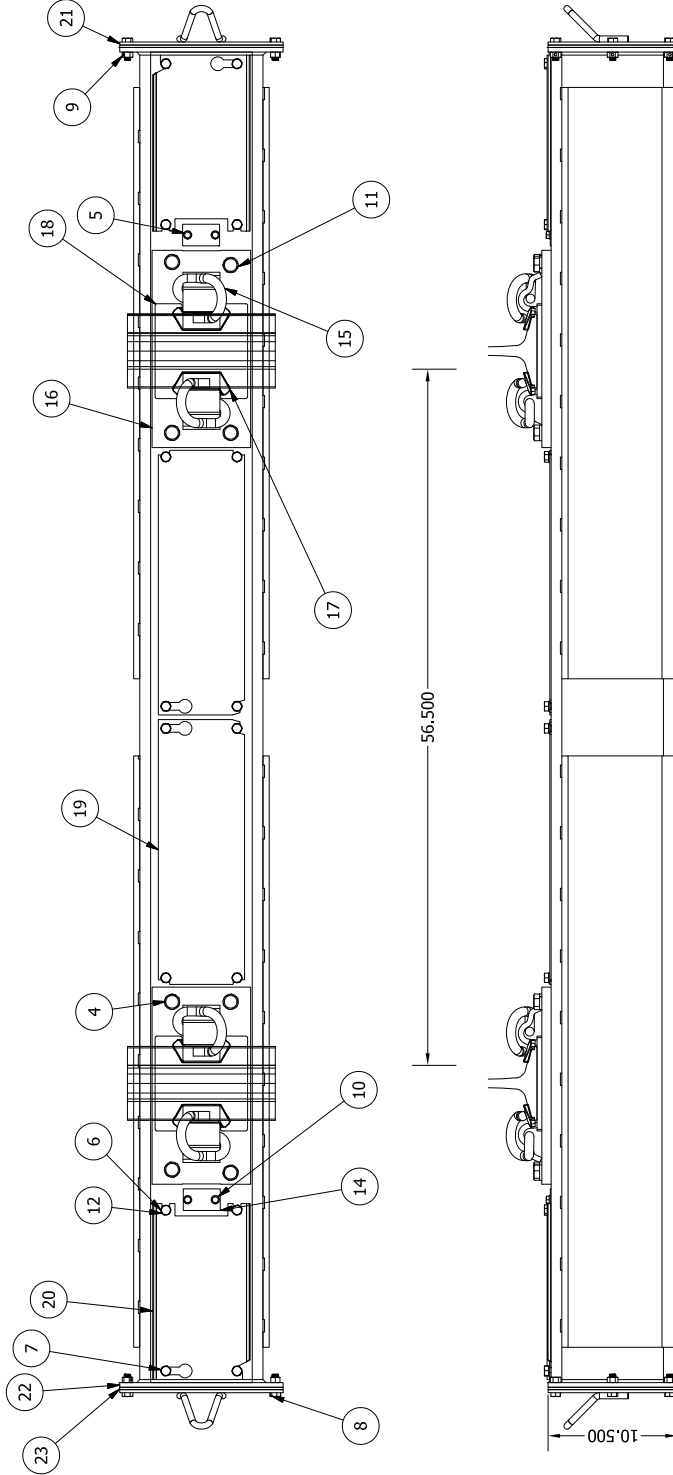

© RAILWAY EQUIPMENT CO. 2018

UNLESS OTHERWISE SPECIFIED:
 DIMENSIONS IN PARENT SQUARE BRACKETS ARE ANGULAR
 DIMENSIONS IN PARENT PARENTHESES ARE FRACTIONS
 .XX, 4.01" FRACTIONS
 .XX, 4.01" FRACTIONS
 DO NOT SCALE DRAWINGS

DRAWN: TBERTOLDI

DATE: 1/24/2019

REVISION: A

DWG NO: 9528-4615A

SCALE: 1/10

SHEET 1 OF 1

TITLE: TIE DUCT, 115# QUICK CHANGE, 6-HOLE FLANGE

PARTS LIST					
ITEM	PART NUMBER	REV	QTY	UOM	DESCRIPTION
1	28106	-	8	EA	SPACER, .38X.625X.375 ROUND
2	2832-8101	-	8	EA	NUT, 3/8-16 HEX
3	2833-8110	-	8	EA	WASHER, 3/8 FLAT
4	2833-8210	-	8	EA	WASHER, 3/8 SPLIT LOCK
5	2833-9014	-	4	EA	WASHER, 5/8 FLAT SAE
6	2833-9015	B	8	EA	WASHER, ISOLATING NOZZLE
7	60195	-	2	FT	GASKET, .25 X 1.0 ADHESIVE BK
8	92742	-	2	EA	SPRING, TRACK DUCT SUPPORT
9	92743	B	2	EA	CLIP, HOLDDOWN SPRING
10	92745	A	1	EA	HOLDDOWN STRAP, T. DUCT
11	927488	A	1	EA	NOZZLE, TRACK DUCT, NO DAMPER
12	92757	D	1	EA	GASKET, ISO, PT NOZZLE RED
13	92759	B	1	EA	GASKET, ISO, TR NOZZLE RED
14	927600C	C	1	EA	POINT/TD NOZZLE MOUNT PLATE RH
15	927701	A	1	EA	SCREEN, POINT NOZZLE
16	927702	A	1	EA	SCREEN TRACK DUCT NOZZLE LARGE
17	9361-0071A	A	1	EA	POINT NOZZLE, ROUND, 4", GALV
18	R9508-4000C	C	1	EA	LABEL, QUICK NOZZLE ASSY RH

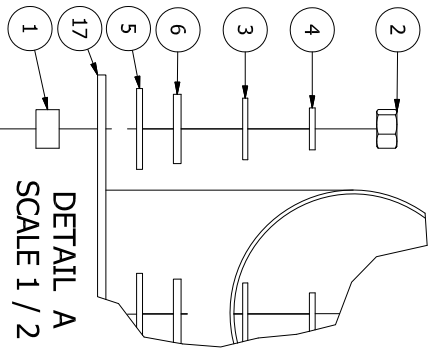

DETAIL A
SCALE 1 / 2

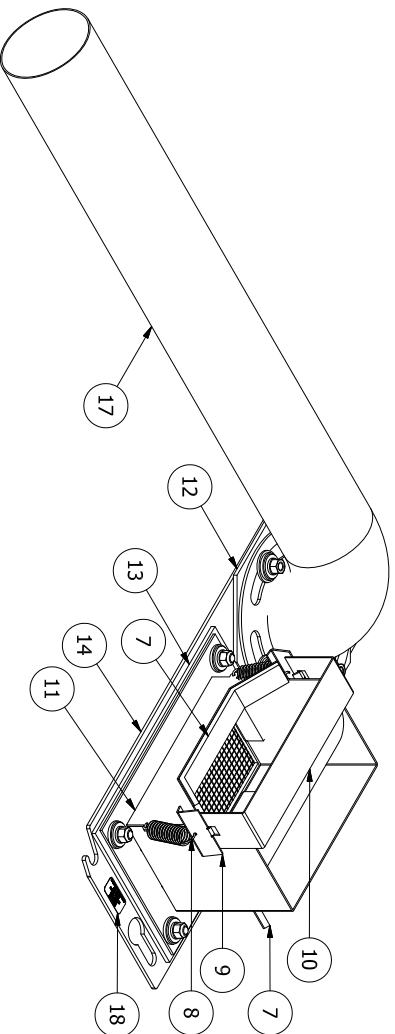

DETAIL B
SCALE 1 / 2

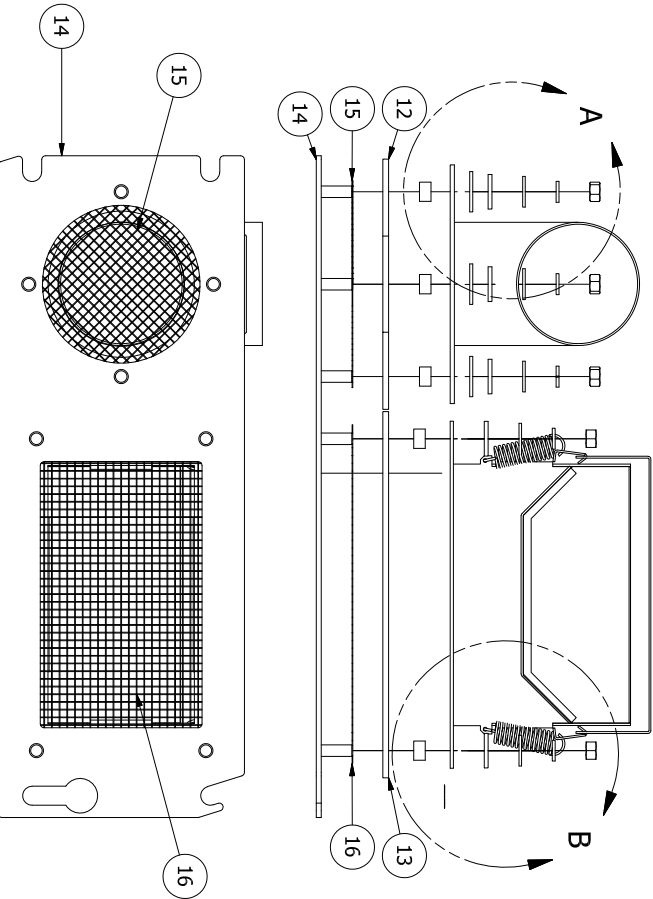

UNLESS OTHERWISE SPECIFIED:	
DIMENSIONS ARE IN INCHES	
DECIMALS .0001" ANGULAR	
.005" & .010" FRACTIONS	
.0005" & .001" DECIMAL EQUIVALENTS	
LAST UPDATE	10/5/2020
BY	akolman
DATE	10/5/2020
WFLY N/A	
BRD ALLOWANCE	N/A
DWG NO.	9508-4000C
SCALE	1/5
DWG SIZE	B
SHEET	1 OF 1
REV	C

© RAILWAY EQUIPMENT CO. 2020

RAILWAY EQUIPMENT CO.
MINNEAPOLIS, MINNESOTA (763) 972-2200

POINT/TRACK NOZZLE ASSY RH

REVISION HISTORY				
REV	ECO #	DESCRIPTION	DATE	BY
B	18-0011	ROUND POINT NOZZLE	10/23/2018	TB
C	-	4" ROUND POINT NOZZLE	8/13/2020	AK
-	-	UPDATES PER REVIEW PROCESS	10/05/2020	AK

REVISION HISTORY				
REV	ECO #	DESCRIPTION	DATE	BY
B	18-0011	ROUND POINT NOZZLE	10/23/2018	TB
C	-	4" ROUND POINT NOZZLE	8/13/2020	AK
-	-	UPDATES PER REVIEW	10/05/2020	AK

PARTS LIST				
ITEM	PART NUMBER	REV	QTY	DESCRIPTION
1	28106	-	8	SPACER, .38X.625X.375 ROUND
2	2832-8101	-	8	NUT, 3/8-16 HEX
3	2833-8110	-	8	WASHER, 3/8 FLAT
4	2833-8210	-	8	WASHER, 3/8 SPLIT LOCK
5	2833-9014	-	4	WASHER, 5/8 FLAT SAE
6	2833-9015	B	8	WASHER, ISOLATING NOZZLE
7	60195	-	2	GASKET, .25 X 1.0 ADHESIVE BK
8	92742	-	2	SPRING, TRACK DUCT SUPPORT
9	92743	B	2	CLIP, HOLDDOWN SPRING
10	92745	A	1	HOLDDOWN STRAP, T. DUCT
11	92748	A	1	NOZZLE, TRACK DUCT, NO DAMPER
12	92757	D	1	GASKET, ISO, PT NOZZLE RED
13	92759	B	1	GASKET, ISO, TR NOZZLE RED
14	927606C	C	1	POINT/TD NOZZLE MOUNT PLATE LH
15	927701	A	1	SCREEN, POINT NOZZLE
16	927702	A	1	SCREEN TRACK DUCT NOZZLE LARGE
17	9361-0071A	A	1	POINT NOZZLE, ROUND, 4", GALV
26	R9508-4001C	C	1	LABEL, QUICK NOZZLE ASSY LH

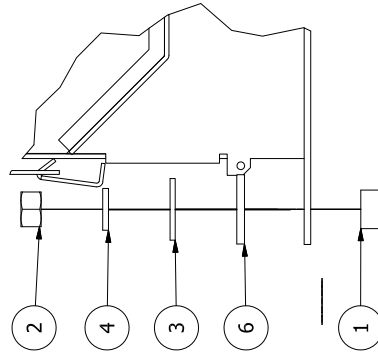
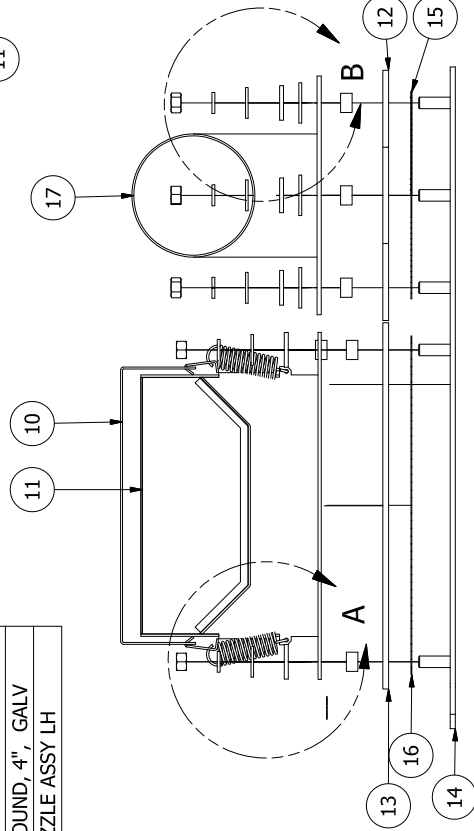
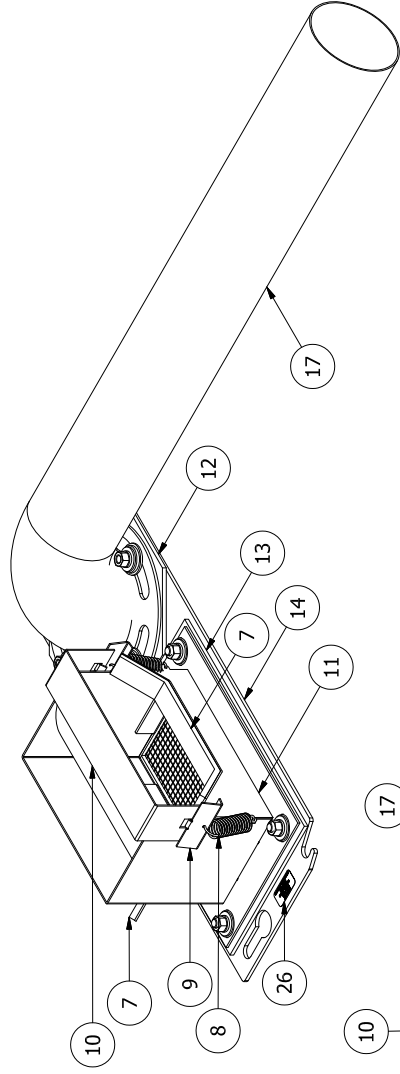

DETAIL A
SCALE 1 / 2

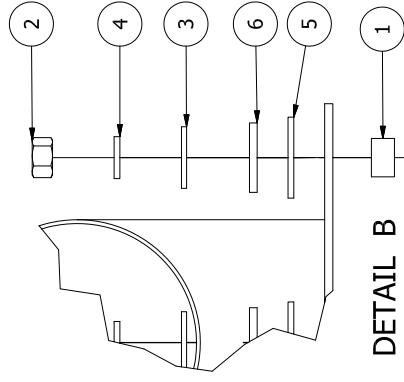

DETAIL B
SCALE 1 / 2

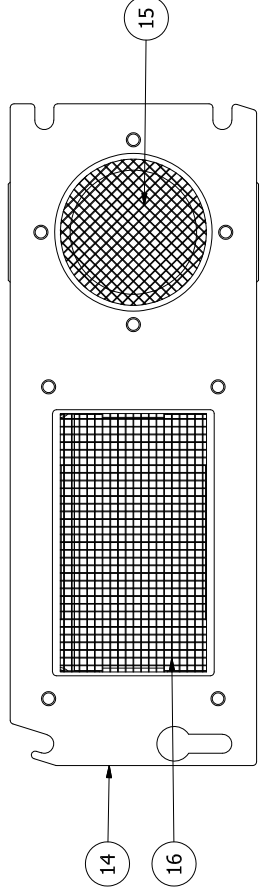

© RAILWAY EQUIPMENT CO. 2020	
RAILWAY EQUIPMENT CO. MINNEAPOLIS, MINNESOTA (763) 972-2200	
TITLE: POINT/TRACK NOZZLE ASSY LH	
LAST UPDATED: 10/5/2020	REV: akollman
MATERIAL: N/A	9508-4001C
BEND ALLOWANCE: N/A	SCALE: 1/5
DRAWING NO: 9508-4001C	
SHEET 1 OF 1	

ITEM	PART NUMBER	REV	QTY	UOM	DESCRIPTION
1	28106	-	4	EA	SPACER, .38X.625X.375 ROUND
2	2832-8101	-	4	EA	NUT, 3/8-16 HEX
3	2833-8110	-	4	EA	WASHER, 3/8 FLAT
4	2833-8210	-	4	EA	WASHER, 3/8 SPLIT LOCK
5	2833-9015	B	4	EA	WASHER, ISOLATING NOZZLE
6	60195	-	2	FT	GASKET, .25 X 1.0 ADHESIVE BK
7	92742	B	2	EA	SPRING, TRACK DUCT SUPPORT
8	92743	B	2	EA	CLIP, HOLDDOWN SPRING
9	92745	A	1	EA	HOLDDOWN STRAP, T. DUCT
10	927488	A	1	EA	NOZZLE, TRACK DUCT, NO DAMPER
11	92759	B	1	EA	GASKET, ISO, TR NOZZLE RED
12	927604	B	1	EA	TRACK DUCT NOZZLE MOUNT PLATE
13	927702	A	1	EA	SCREEN TRACK DUCT NOZZLE LARGE
14	R9508-4002	A	1	EA	LABEL, QUICK NOZZLE ASSY LH

PARTS LIST

REVISION HISTORY				
REV	ECO #	DESCRIPTION	DATE	BY
A	06-0024	NEW PART	10/24/2006	WS

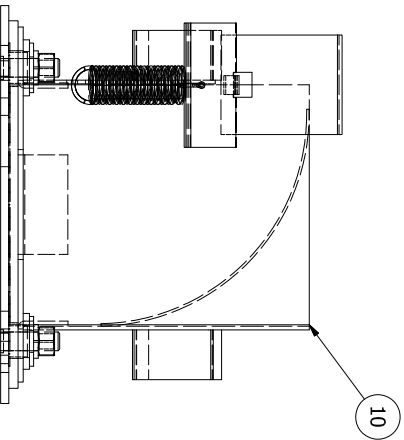
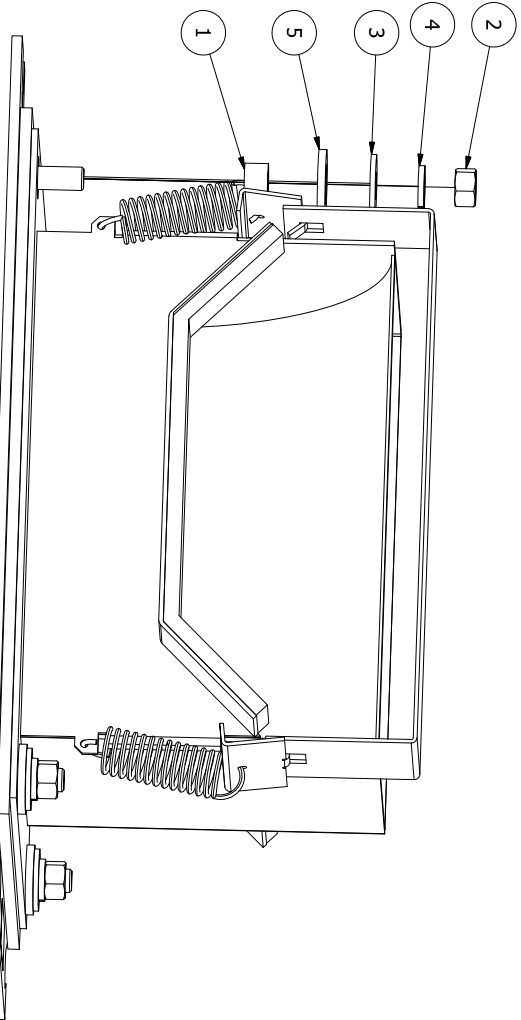
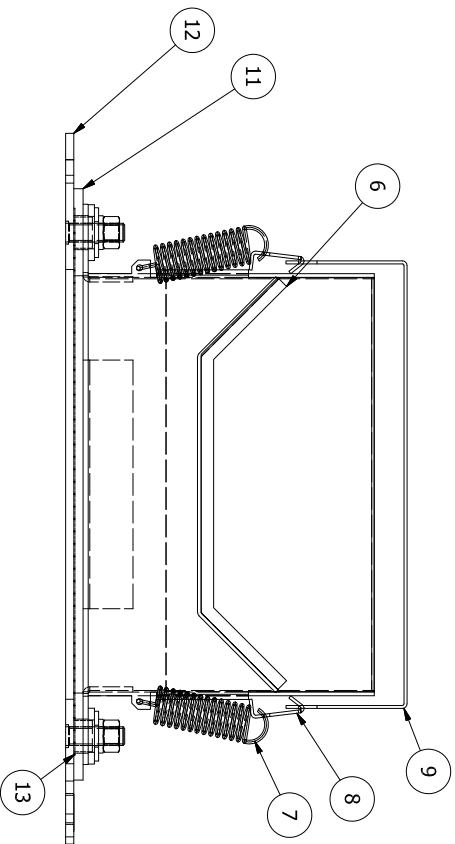
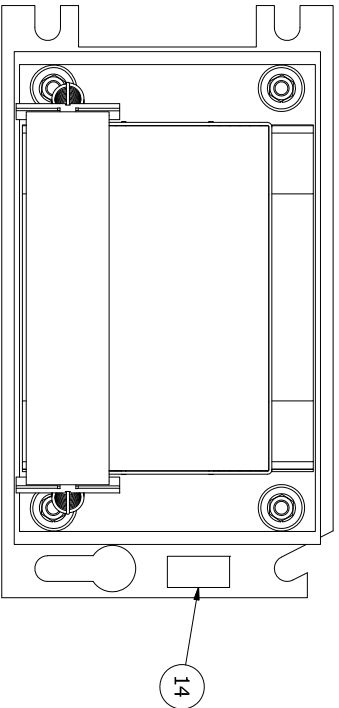

© RAILWAY EQUIPMENT CO. 2020

RAILWAY EQUIPMENT CO.

MINNEAPOLIS, MINNESOTA (763) 978-2200

UNLESS OTHERWISE SPECIFIED DIMENSIONS ARE IN INCHES		DRAWING NO. 9508-4002	
DECIMALS	FRACTIONS	DATE	REV.
.XX 1/1000	1/16 1/32	1/17/2020	A
3/16 1/8 1/4 3/8 1/2 5/8 3/4 7/8 1 1 1/4 1 1/2 1 3/4 2 2 1/4 2 1/2 3 3 1/4 3 1/2 4 4 1/4 4 1/2 5 5 1/4 5 1/2 6 6 1/4 6 1/2 7 7 1/4 7 1/2 8 8 1/4 8 1/2 9 9 1/4 9 1/2 10		BY: CwAnderson	
CHECK APPROVED: _____		DRAWN BY: _____	
DATE: _____		SCALE: 1/2.5	
MATERIAL: NA		DOWNSIDE: B	
REVISIONS: NA		SHEET 1 OF 1	

OUTSIDE TRACK NOZZLE ASSY

LH

REV	ECO #	DESCRIPTION	DATE	BY
A	06-0024	NEW PART	10/24/2006	WS

REVISION HISTORY				
REV	ECO #	DESCRIPTION	DATE	BY
A	06-0024	NEW PART	10/24/2006	WS

ITEM	PART NUMBER	REV	QTY	UOM	DESCRIPTION
1	28106	-	4	EA	SPACER, .38X.625X.375 ROUND
2	2832-8101	-	4	EA	NUT, 3/8-16 HEX
3	2833-8110	-	4	EA	WASHER, 3/8 FLAT
4	2833-8210	-	4	EA	WASHER, 3/8 SPLIT LOCK
5	2833-9015	B	4	EA	WASHER, ISOLATING NOZZLE
6	60195	-	2	FT	GASKET, .25 X 1.0 ADHESIVE BK
7	92742	B	2	EA	SPRING, TRACK DUCT SUPPORT
8	92743	B	2	EA	CLIP, HOLDDOWN SPRING
9	92745	A	1	EA	HOLDDOWN STRAP, T. DUCT
10	927488	A	1	EA	NOZZLE, TRACK DUCT, NO DAMPER
11	92759	B	1	EA	GASKET, ISO, TR NOZZLE RED
12	927604	B	1	EA	TRACK DUCT NOZZLE MOUNT PLATE
13	927702	A	1	EA	SCREEN TRACK DUCT NOZZLE LARGE
14	R9508-4003	A	1	EA	LABEL, QUICK NOZZLE ASSY RH

PARTS LIST

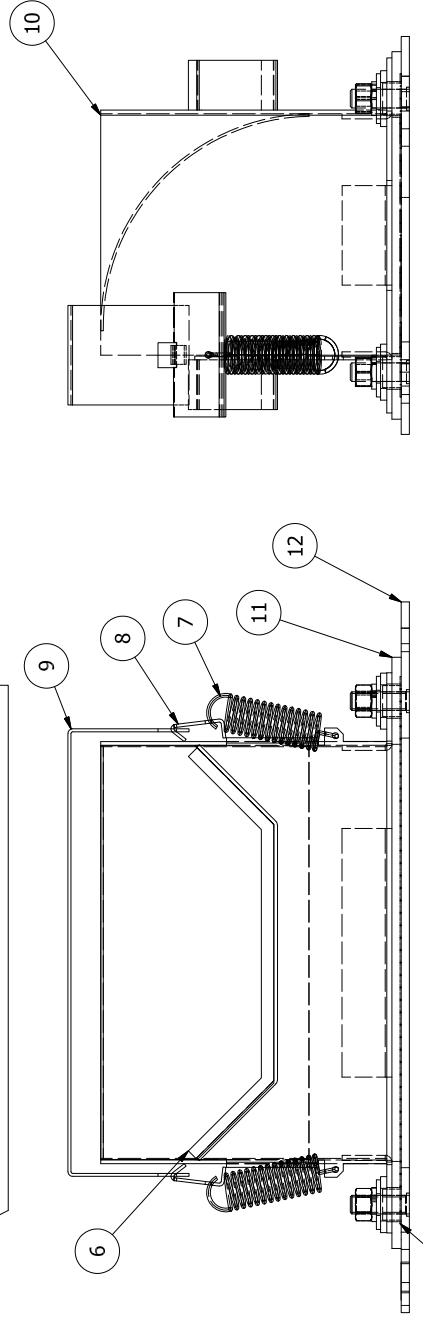
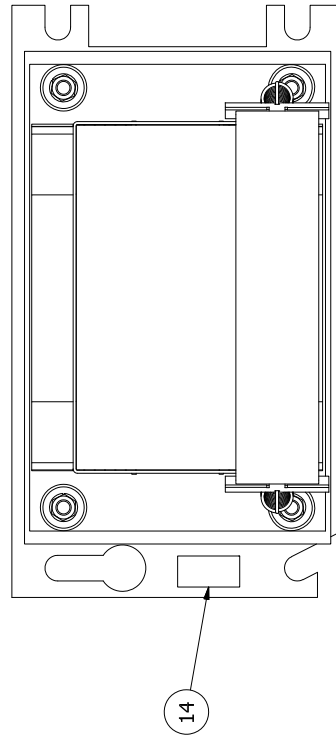
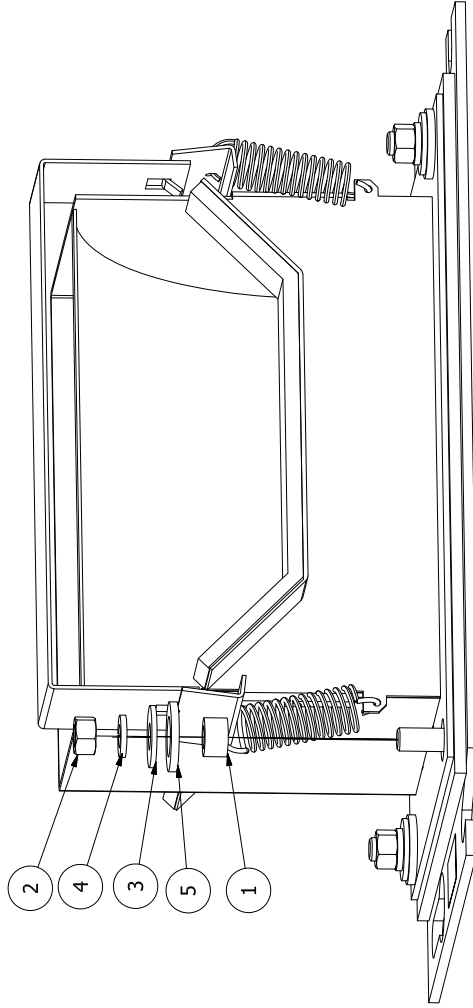

UNLESS OTHERWISE SPECIFIED: DIMENSIONS ARE IN INCHES DECIMALS TO THIRDS FRACTIONS TO SIXTEENTHS ANGULAR TOLESANCES XX - 1:1000 XX - 1:5000 XX - 1:25000 XX - 1:125000 LAST UPDATED: 12/8/2020		© RAILWAY EQUIPMENT CO. 2020 RAILWAY EQUIPMENT CO. MINNEAPOLIS, MINNESOTA (763) 972-2200	
TITLE: OUTSIDE TRACK NOZZLE ASSY RH QUICK CHANGE		DWG NO:	REV:
BY: cwanderson		9508-4003	A
MATERIAL: NA		SCALE: 1/2.5	DWG SIZE: B
BEND ALLOWANCE:		SHEET 1 OF 1	

PARTS LIST					
ITEM	PART NUMBER	REV	QTY	UOM	DESCRIPTION
1	60195	-	1.67	FT	GASKET, .25 X 1.0 ADHESIVE BK
2	92742	-	2	EA	SPRING, TRACK DUCT SUPPORT
3	92743	B	2	EA	CLIP, HOLDDOWN SPRING
4	92745	A	1	EA	HOLDDOWN STRAP, T. DUCT
5	927488	A	1	EA	NOZZLE, TRACK DUCT, NO DAMPER
6	R927490A	-	1	EA	LABEL, ID, TRACK DUCT NOZZLE, ASSEMBLY

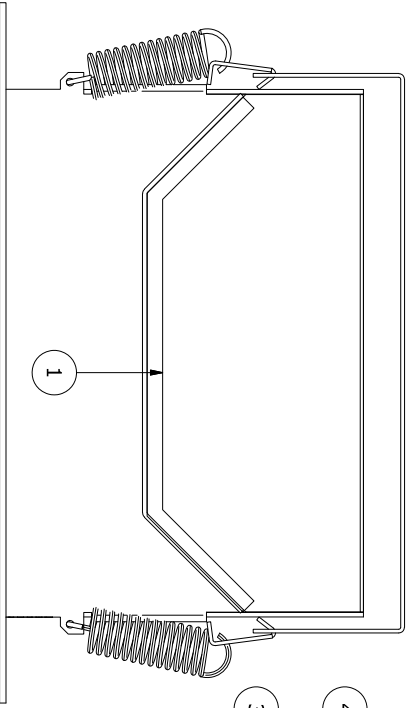
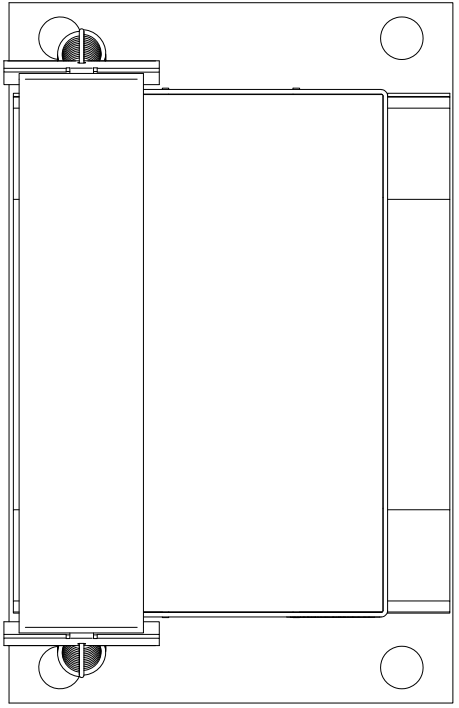

REVISION HISTORY				
REV	ECO #	DESCRIPTION	DATE	BY
A	06-0028	NEW PART	11/30/2006	RMJ
-	-	NEW DRAWING WITH REV LETTER	8/25/2020	AK

3D VIEW

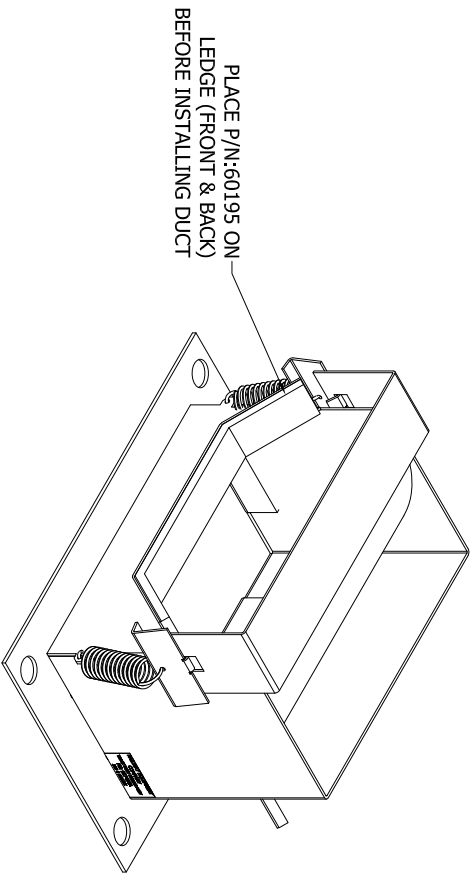

PLACE P/N:60195 UNDER STRAP FOR TRANSPORTATION.

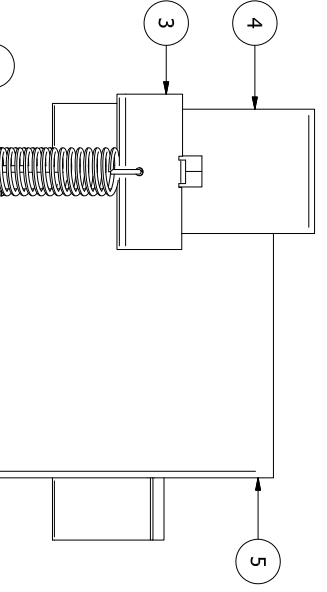

© RAILWAY EQUIPMENT CO. 2020

RAILWAY EQUIPMENT CO.
MINNEAPOLIS, MINNESOTA (763) 978-2200

UNLESS OTHERWISE SPECIFIED:
DIMENSIONS ARE IN INCHES
DECIMALS ANGULAR
XX 1/16 1/32 1/64 FRACTIONS
X.XX DO NOT SCALE DRAWINGS

DATE: 8/25/2020
BY: skollman

NOZZLE, TRACK DUCT ASSY

DWG NO: 927490A
REV: A

SCALE: 1/2
TOW SIZE: B
SHEET 1 OF 1

RAILWAY EQUIPMENT CO.
2000 W. WASHINGTON
MINNEAPOLIS, MN 55408

REV.	E.C.A.	BY	REVISION DESCRIPTION	DATE	APPROVED
B		TB	ADD 927701	10/19/00	---
C	06-002B	RJ	CORNERS CUT OFF ON DUCT	11/29/06	---

ITEM NO.	PART NO.	UOM	QTY	DESCRIPTION
1	2831851114	EA	4	BOLT, HEX HD 3/8-16 x 1" SS
2	2833-8110	EA	4	WASHER, PLAIN 3/8"
3	2833-9015B	EA	4	WASHER, INSULATOR
4	28106	EA	4	SPACER, ROUND, .38 X .625 X .375
5	92757D	EA	1	GASKET, POINT NOZZLE
6	2833-9014	EA	4	WASHER, 5/8 FLAT PLATED
7	14046	EA	1	BAG, ZIPTOP 9x12 4mil
8	2833-8210	EA	4	WASHER, SPLIT LOCK 3/8"
9	927701A	EA	1	SCREEN, POINT NOZZLE

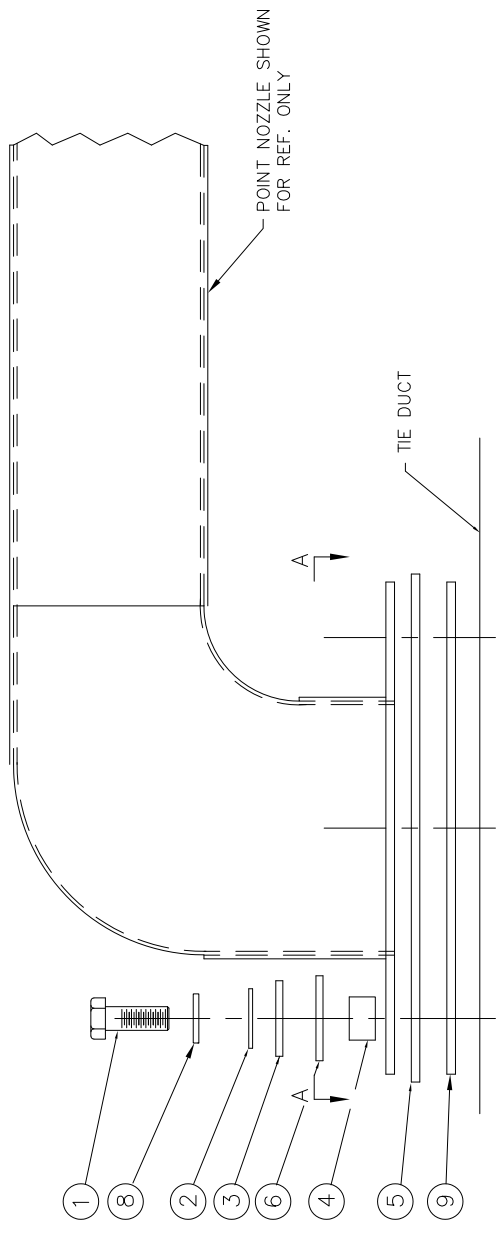

POINT NOZZLE SHOWN FOR REF. ONLY

7

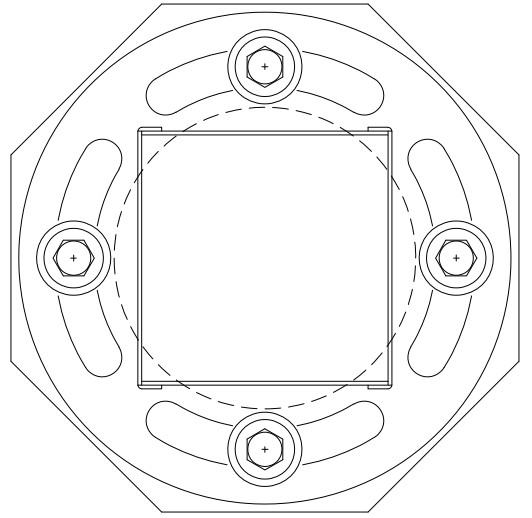

SECTION A-A

UNLESS OTHERWISE SPECIFIED: DIMENSIONS ARE IN INCHES AND DECIMALS THEREOF. FRACTIONS SHALL BE IN 16ths. DO NOT SCALE DRAWING.	
DATE	04/11/97
MATERIAL	N/A
TIE BEND ALLOWANCE	N/A
SCALE	1/4" = 1"
DRAWN	EFK
TITLE	ISOLATION KIT ASSEMBLY POINT NOZZLE TIE DUCT
PWC NO.	9278-0021
REV	C
SHEET	1 OF 1

© RAILWAY EQUIPMENT CO. 1997-2002
RAILWAY EQUIPMENT CO.
 DELANO, MINNESOTA (763) 972-3200

ITEM NO.	PART NO.	UOM	QTY	DESCRIPTION
1	283185114	EA	4	BOLT, HEX. 3/8-16 x 1" SS
2	2833-810	EA	4	WASHER, FLAIN 3/8
3	2833-9015	EA	4	WASHER, INSULATOR
4	28106	EA	4	SPACER, ROUND .36 X .625 X .375
5	92739	EA	1	GASKET, TRACK DUCT NOZZLE
6	60199	FT	1.67	GASKET, ADHESIVE .25 X 1"
7	14045	EA	1	BAG, ZIPTOP 12 X 19 4mm
8	2833-8210	EA	4	WASHER, SPLIT LOCK 3/8
9	927702	EA	1	SCREEN, TRACK DUCT NOZZLE
10	R9278-0027A	EA	1	DRAMING, ISO KIT, TRACK NOZZLE
11	R92780027A	EA	1	LABEL, BAG LABEL ISO KIT TRACK

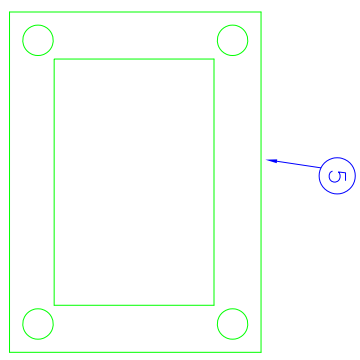
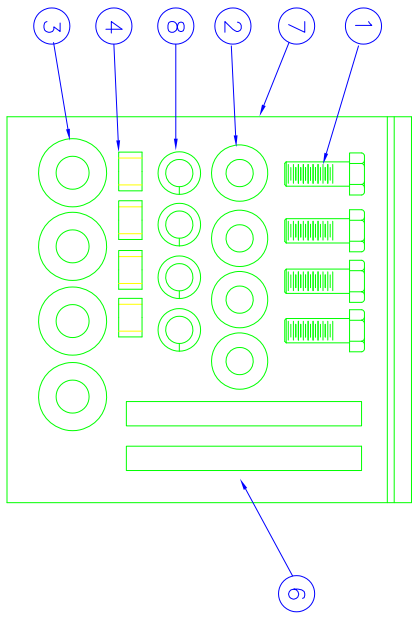
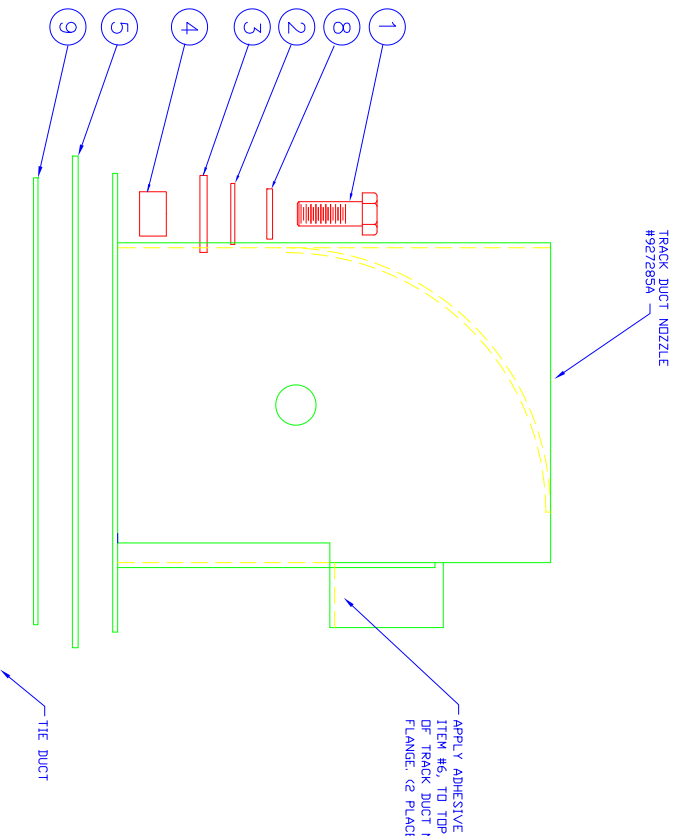

PAGE	COL.	REV.	REVISION DESCRIPTION	DATE	APPROVED
A	005	TB	NEW PART	12/29/00	

UNLESS OTHERWISE SPECIFIED

ALL DIMENSIONS ARE IN INCHES	UNLESS OTHERWISE SPECIFIED
FINISHES	AS NOTED
TO INDICATES FINISHES NOT SHOWN	AS NOTED
REF. CONNECTION DIA.	MATERIAL

DATE: 12/19/00

DRAWN BY: T. BUHL

CHECKED BY:

APPROVED BY:

SHEET 1 OF 1

PART NO. 9278-0027

REV. A

© RAILWAY EQUIPMENT CO. 2000

RAILWAY EQUIPMENT CO.
DIXON, ILLINOIS (781) 975-8000

ASSY, ISO KIT TRACK NOZZLE THE DUCT

REV	ECO	DESCRIPTION	DATE	BY
A	06-0028	NEW PART	10/9/06	WS

ITEM	PART NUMBER	REV	UOM	QTY	DESCRIPTION
1	14046	-	EA	1	BAG, 9 X 12 4MIL ZIPTOP
2	14150	-	EA	1	BAG, BURLAP 10" X 14" 100Z
3	14151	-	EA	2	WIRE BURLAP BAG CLOSING TIES 6"
4	14153	-	EA	1	BAG, WOVEN YELLOW 23.5 X 46
5	2831-9511	-	EA	4	BOLT, 3/4-10 X 8 HEX TAP
6	2831951121	-	EA	24	BOLT, 1/2-13 X 1.25 HEX SS
7	2832-9002	-	EA	24	NUT, 1/2-13 HEX
8	2832-9102	-	EA	12	NUT, 3/4-10 HEX
9	2833-9002	-	EA	24	Helical Spring Lock Washer
10	2833-9009	-	EA	12	WASHER, 3/4 SPLIT LOCK
11	2833-9010	-	EA	12	WASHER, 3/4 FLAT
12	60169	-	EA	1	TY-RAP, 0.30 X 8
13	92852B	B	EA	4	UPRIGHT LEG SHORT FOUNDATION
14	92855B	B	EA	2	BASE FOUNDATION
15	92856C	C	EA	2	TOP 6HP FOUNDATION
16	92859B	B	EA	2	FOUNDATION SUPPORT BRACE LARGE
17	R9288-0300	A	EA	1	INSTRUCTION SHEET FOUNDATION

Paris List

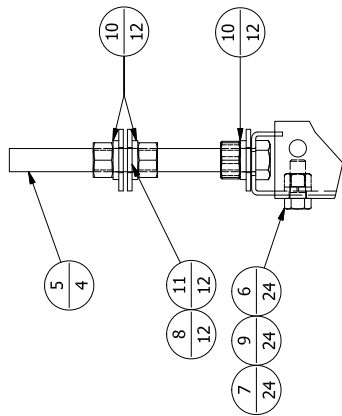

DETAIL A
SCALE 1 / 4

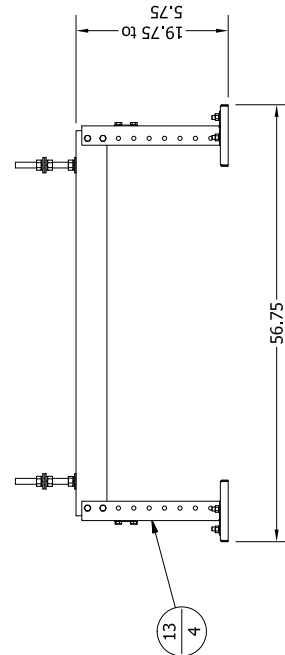
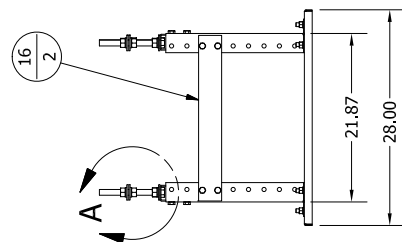
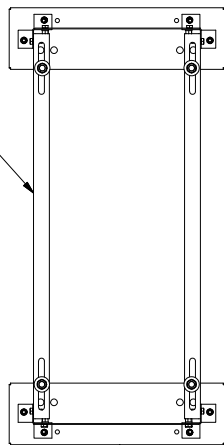
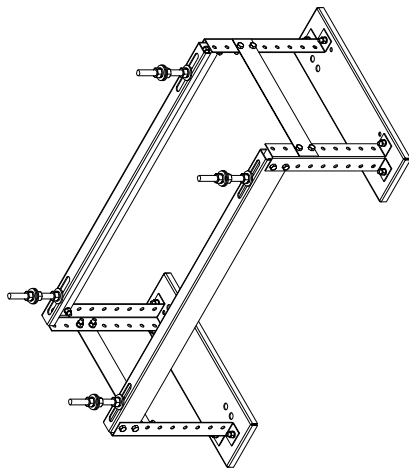

UNLESS OTHERWISE SPECIFIED:
DIMENSIONS ARE IN INCHES
DECIMALS - FRACTIONS
.XX - .99 FRACTIONS
DO NOT SCALE DRAWING

DRAWN: WS

DATE: 10/9/06

NOTE: SEE B.O.M.

SCALE: 1/16

SCALE: 1/16

DWG NO: 9288-0302

REV: A

SHEET 1 OF 1

© RAILWAY EQUIPMENT CO. 2006

RAILWAY EQUIPMENT CO.
DELANO, MINNESOTA (763) 972-2200

TITLE: FOUNDATION ASSY, 5HP GHAB
(ASSEMBLY)

PARTS LIST				DESCRIPTION	
ITEM	PART NUMBER	REV	QTY	UOM	
1	29019	-	8	EA	BOLT, 1/4-20 X 1.3 SHOULDER THREAD ROLLING
2	32002	A	6	SQFT	INSULATION, FIBERGLASS
3	6093-0102	-	1	EA	TY-RAP
4	952224C	C	1	EA	DUCT, OFFSET, WITH HEAVY BASE
5	952226C	C	1	EA	INSUL COVER, OFFSET DUCT
6	9528-0074D	D	1	EA	GASKET KIT, 9X9 SHP FLEX

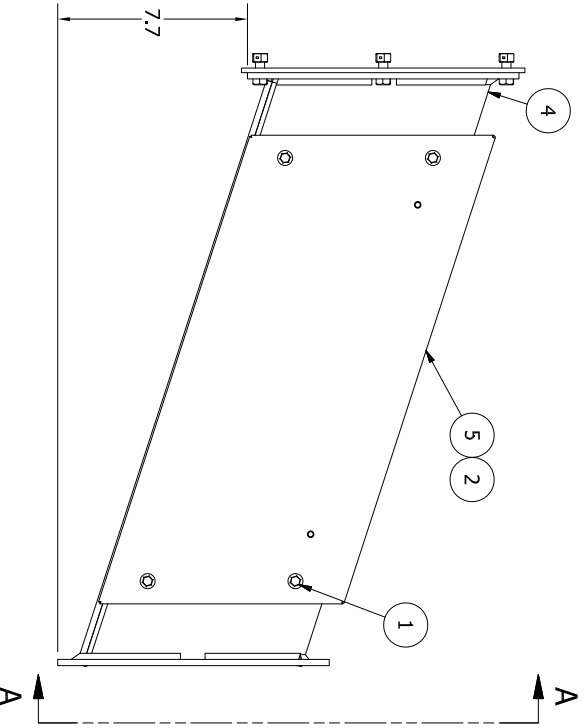
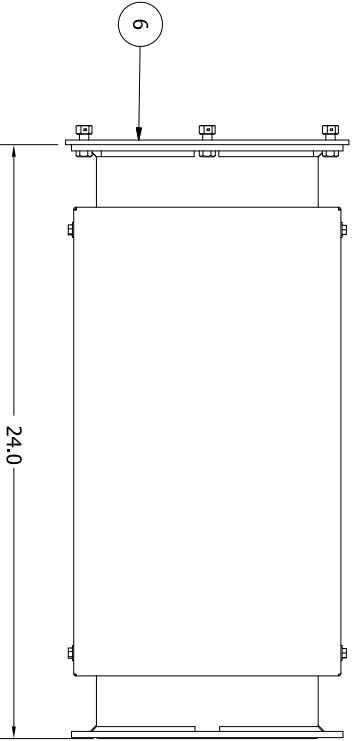

REVISION HISTORY				
REV	ECO #	DESCRIPTION	DATE	BY
A	05-0008	NEW PART	09/07/05	RF
B	16-0015	DUCT TOP CHANGE	10/10/2016	JT
C	16-0015	SHORTENED WRAP, 1/4" BASE	11/22/2016	BJM
ADDED DIMENSIONS				

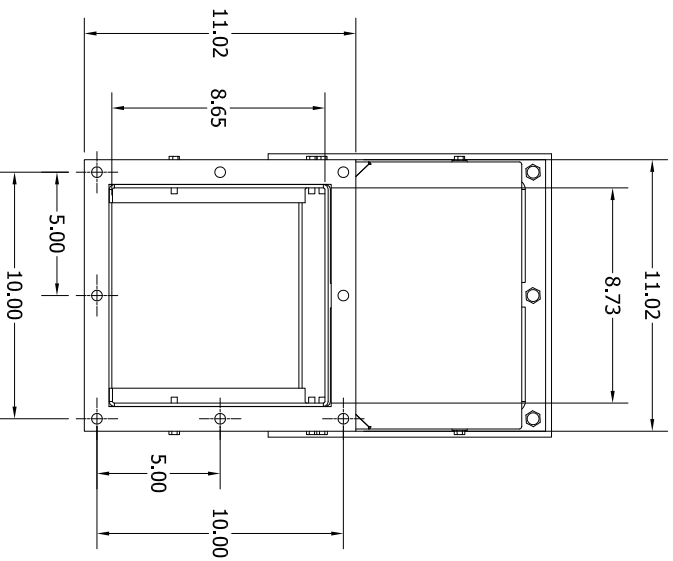

VIEW A-A
SCALE 1 / 5

© RAILWAY EQUIPMENT CO. 2016

UNLESS OTHERWISE SPECIFIED:		DIMENSIONS ARE IN INCHES	
DECIMALS		ANGULAR	
.XX, .X AND .XXX		FRACTIONS	
1/32, 1/16, 1/8, 3/16, 1/4, 3/8, 1/2, 5/8, 3/4		EQUIVALENTS	
DRAWN: JT		TITLE	
DATE: 10/10/2016		DUCT, OFFSET, 2' HD NO MIXER	
WALT:		DWG NO: 9528-3404C	
REVISION ALLOWANCE:		DWG SER: B	
		SHEET 1 OF 1	

REV	ECO #	DESCRIPTION	DATE	BY
A	08-0003	NEW PART	7/26/10	ES
-	-	9528-4222A to 9528-5222A	09/17/2021	AK

ITEM	PART NUMBER	REV	UOM	QTY	DESCRIPTION
1	28105	-	EA	2	CLAMP, HOSE SST 18 INCH
2	29051	-	EA	6	BOLT, 1/4-20 X 1/2 WITH 1/2 HD
3	6093-0100	-	EA	1	CABLE TIE, 4IN 0.10 WIDTH
4	927237	A	EA	1	COVER PLATE, TEMP SENSOR
5	952423	A	EA	1	FLEX WRAP, BOTTOM 2'
6	952424A	A	EA	1	FLEX WRAP, TOP 2' 3/5HP HAB
7	952426A	A	EA	1	FLEX DUCT, TRANSITION WELDMENT, W/ MIXER
8	952427A	A	EA	1	FLEX DUCT, TRANSITION WELDMENT, W/ T.S.
9	952429	A	EA	1	RUBBER TUBE 11.5" ID 11" LONG
10	9528-0074D	D	EA	1	GASKET KIT, 9X9 5HP DUCTWORK
11	R9528-5222A	A	EA	1	LABEL, FLEX DUCT TO BLOWER

PARTS LIST					
ITEM	PART NUMBER	REV	UOM	QTY	DESCRIPTION
1	28105	-	EA	2	CLAMP, HOSE SST 18 INCH
2	29051	-	EA	6	BOLT, 1/4-20 X 1/2 WITH 1/2 HD
3	6093-0100	-	EA	1	CABLE TIE, 4IN 0.10 WIDTH
4	927237	A	EA	1	COVER PLATE, TEMP SENSOR
5	952423	A	EA	1	FLEX WRAP, BOTTOM 2'
6	952424A	A	EA	1	FLEX WRAP, TOP 2' 3/5HP HAB
7	952426A	A	EA	1	FLEX DUCT, TRANSITION WELDMENT, W/ MIXER
8	952427A	A	EA	1	FLEX DUCT, TRANSITION WELDMENT, W/ T.S.
9	952429	A	EA	1	RUBBER TUBE 11.5" ID 11" LONG
10	9528-0074D	D	EA	1	GASKET KIT, 9X9 5HP DUCTWORK
11	R9528-5222A	A	EA	1	LABEL, FLEX DUCT TO BLOWER

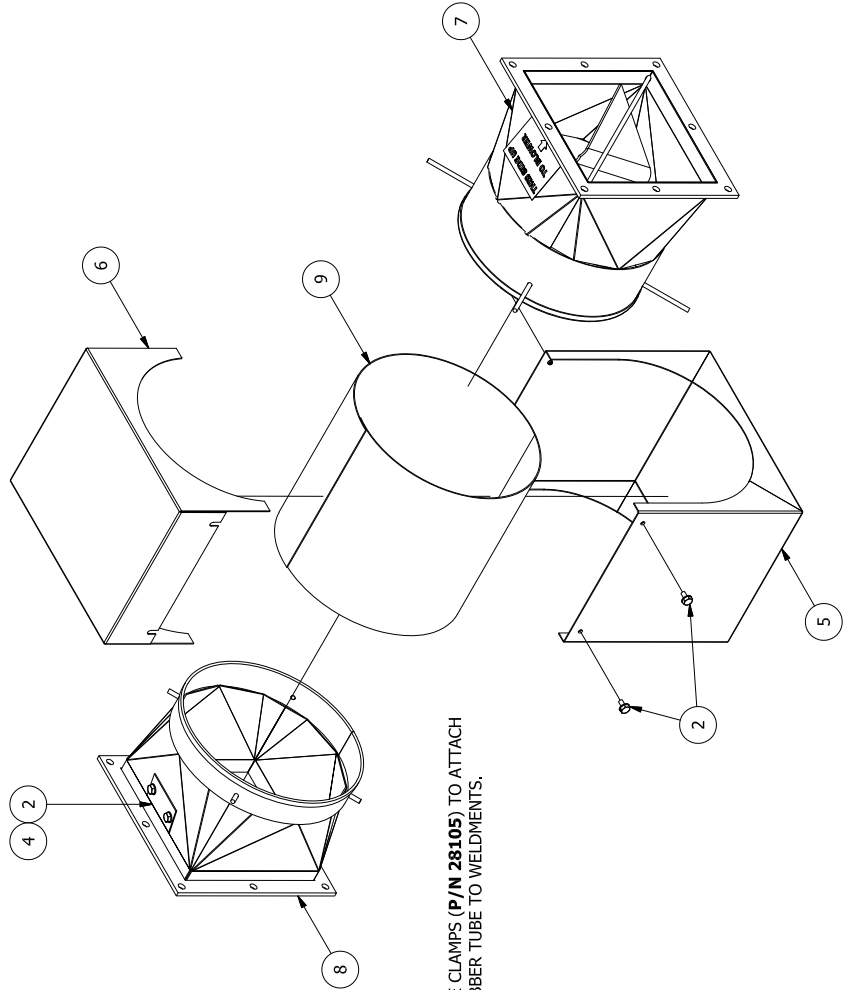
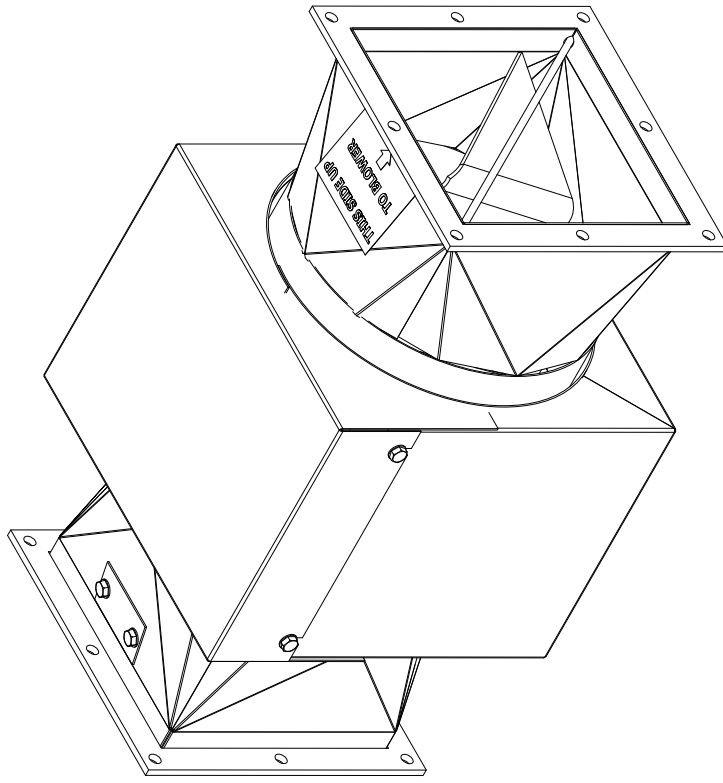

USE CLAMPS (P/N 28105) TO ATTACH RUBBER TUBE TO WELDMENTS.

UNLESS OTHERWISE SPECIFIED:
 DIMENSIONS ARE IN INCHES
 DECIMALS AND FRACTIONS
 .XX, ± 0.010"
 FRACTIONS
 1/16, ± 0.005"
 DO NOT SCALE DRAWINGS

© RAILWAY EQUIPMENT CO. 2009
RAILWAY EQUIPMENT CO.
 MINNEAPOLIS, MINNESOTA (763) 972-2200

TITLE: FLEX DUCT 2' ST INS W/MIXER
 9 X 9 RED RUBBER
 (ASSEMBLY / B. O. M.)

DRAWN: TBERTOLDI
 DATE: 9/21/2018
 MTC: N/A
 REQS: ALLOWANCE
 N/A

DWG NO: 9528-5222A
 SCALE: 1:4
 DWG SIZE: B
 SHEET 1 OF 1

ITEM	PART NUMBER	REV	QTY	UOM	DESCRIPTION
1	2600979300	-	9	EA	NUT, 1/4-20, CLIP ON, STEEL, BLACK PHOSPHATE
2	29051	-	9	EA	BOLT, 1/4-20 X 1/2 WITH 1/2 HD
3	92741F	F	1	EA	TRACK DUCT COVER, 10'
4	92774K	K	1	EA	TRACK DUCT SUPPORT BRACKET
5	9278-2740A	A	1	EA	END PLATE, TRACK DUCT
6	92785E	E	1	EA	DEFLECTOR, TRACK DUCT SML
7	9528-0539A	A	1	EA	TRACK DUCT BASE, 10' W/HOLE

PARTS LIST

REV	ECO #	DESCRIPTION	DATE	BY
A	-	NEW PART	5/24/2005	RF
B	22-054	UPDATED SHEET METAL	6/30/2022	CA

REVISION HISTORY

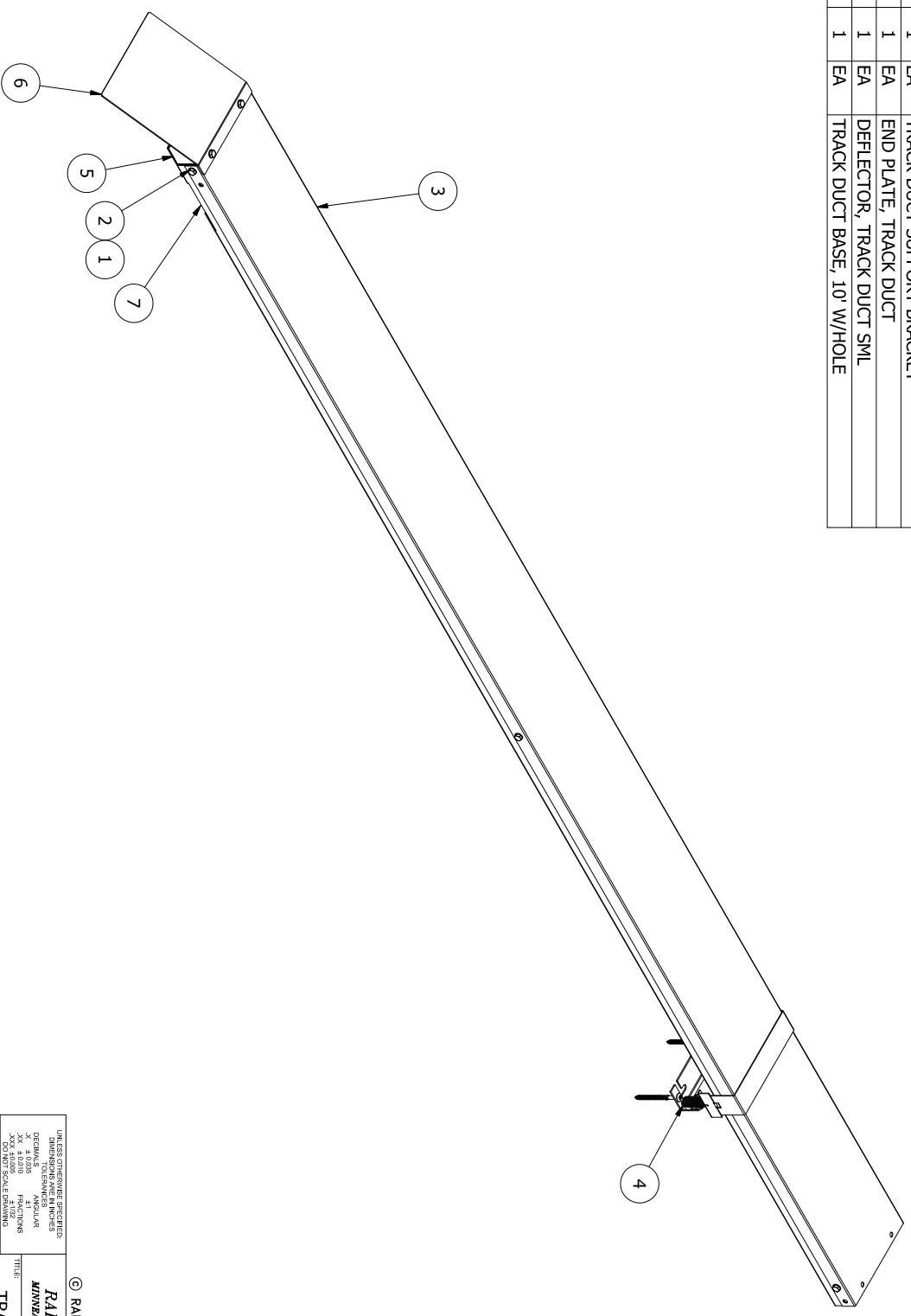

UNLESS OTHERWISE SPECIFIED:
 DIMENSIONS ARE IN INCHES
 DECIMALS ANGULAR
 FRACTIONS
 .000 NOT SCALE DRAWING
 DATE: 6/30/2022
 BY: gwanderson
 DRAWN BY: gwanderson
 MATERIAL: NA
 REVISIONS: NA

RAILWAY EQUIPMENT CO. 2020
 RAILWAY EQUIPMENT CO.
 MINNEAPOLIS, MINNESOTA (763) 978-2200

TITLE:
 TRACK DUCT POINT, LARGE
 NOZZLE 10' SECTION

DWG NO: 9278-1205B
 SCALE: 1/8" = 1'-0"
 DWG SIZE: B
 SHEET 1 OF 1

REV	ECO #	DESCRIPTION	DATE	BY
B	05-0047	NEW SUPPORT ASSM DESIGN	10/27/2005	RO
-	-	REPLACED 927442 WITH 927441	9/1/2020	AK
-	22-054	UPDATED SHEET METAL	7/12/2022	CA

ITEM	PART NUMBER	REV	QTY	UOM	DESCRIPTION
1	2600979300	-	6	EA	NUT, 1/4-20, CLIP ON, STEEL, BLACK PHOSPHATE
2	29051	-	6	EA	BOLT, 1/4-20 X 1/2 WITH 1/2 HD
3	6093-0100	-	1	EA	CABLE TIE, 4IN 0.10 WIDTH
4	92730C	C	1	EA	TRACK DUCT COVER, 5'
5	927441C	C	3	EA	CENTER COVER, E Z SPLICE
6	927450B	B	1	EA	BASE, E Z SPLICE
7	92774K	K	1	EA	TRACK DUCT SUPPORT BRACKET
8	9528-0444A	A	1	EA	TRACK DUCT BASE, 5 FOOT LTD WITHOUT HOLE

PARTS LIST

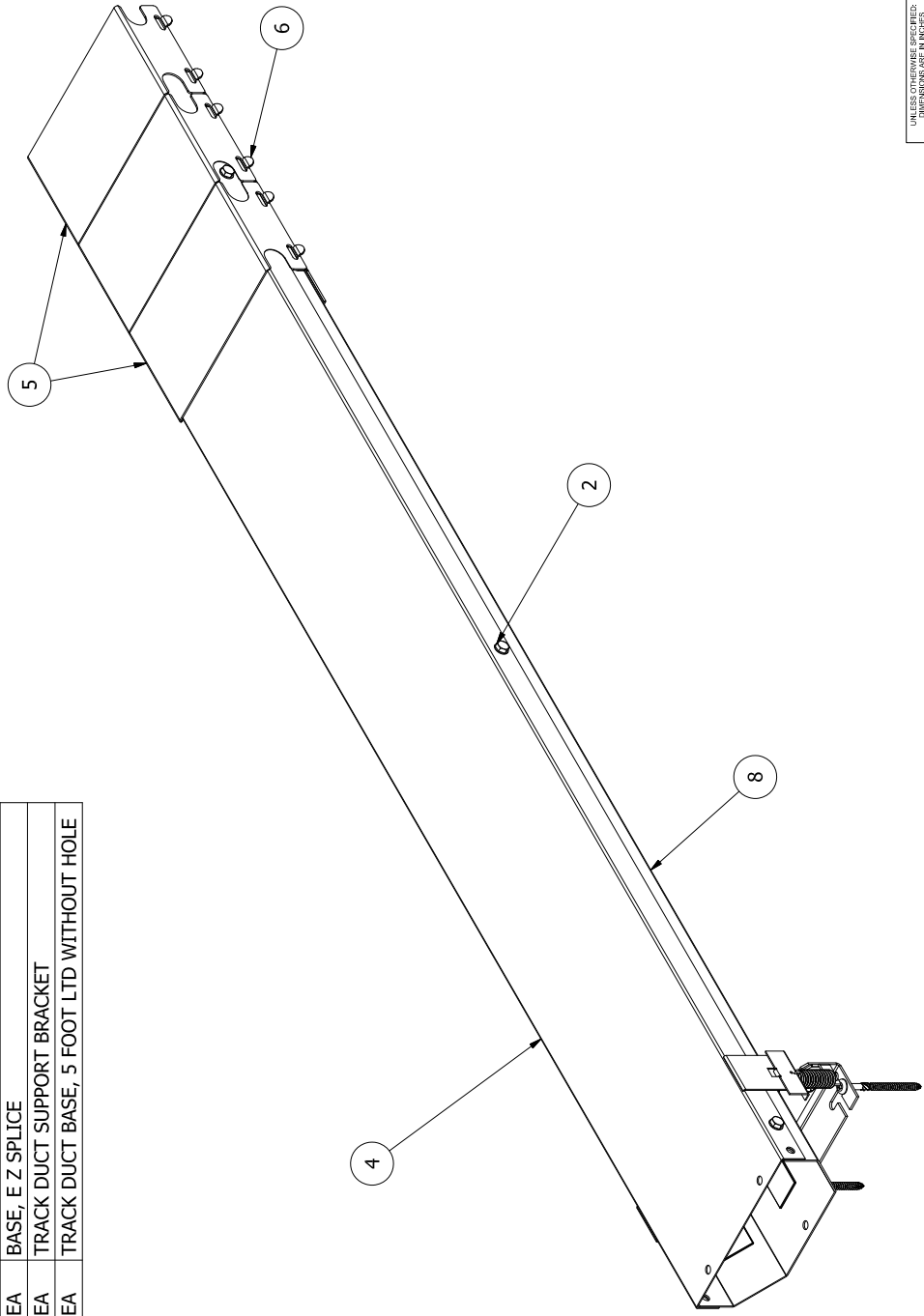

REVISION HISTORY

UNLESS OTHERWISE SPECIFIED:
 DIMENSIONS IN INCHES
 DECIMALS TO THREE PLACES
 ANGULAR TO NEAREST 5'
 FRACTIONS TO NEAREST 1/32"
 .XX = 10/100
 .XXX = 1000/1000
 .XX = 10/100
 .XXX = 1000/1000
 .XX = 10/100
 .XXX = 1000/1000
 .XX = 10/100
 .XXX = 1000/1000
 .XX = 10/100
 .XXX = 1000/1000
 .XX = 10/100
 .XXX = 1000/1000

TITLE: TRACK DUCT, 5', MID

DATE: 07/27/2022

BY: cwanderson

MATERIAL: NA

REVISION: B

SCALE: 1/5

DWG NO: 9278-0227B

SHEET: 1 OF 1

© RAILWAY EQUIPMENT CO. 2020
RAILWAY EQUIPMENT CO.
 MINNEAPOLIS, MINNESOTA (763) 978-2200

ITEM	PART NUMBER	REV	QTY	UOM	DESCRIPTION
1	2600979300	-	6	EA	NUT, 1/4-20, CLIP ON, STEEL, BLACK PHOSPHATE
2	29051	-	6	EA	BOLT, 1/4-20 X 1/2 WITH 1/2 HD
3	6093-0100	-	1	EA	CABLE TIE, 4IN 0.10 WIDTH
4	92741F	F	1	EA	TRACK DUCT COVER, 10'
5	927441C	C	3	EA	CENTER COVER, E Z SPLICE
6	927450B	B	1	EA	BASE, E Z SPLICE
7	92774K	K	1	EA	TRACK DUCT SUPPORT BRACKET
8	9528-0538A	A	1	EA	TRACK DUCT BASE, 10' NO HOLE

PARTS LIST

REV	ECO #	DESCRIPTION	DATE	BY
M	05-0047	NEW SUPPORT ASSEM. DESIGN	10/27/2005	RO
-	-	PN 927441A TO B, 927442 TO 927441	9/29/2020	CA
N	22-054	UPDATED SHEET METAT	6/30/2022	CA

REVISION HISTORY

NOTE: LEAVE TRACK DUCT SUPPORT BRACKET IN BAG AND TAPE TO INSIDE OF DUCT FOR SHIPPING

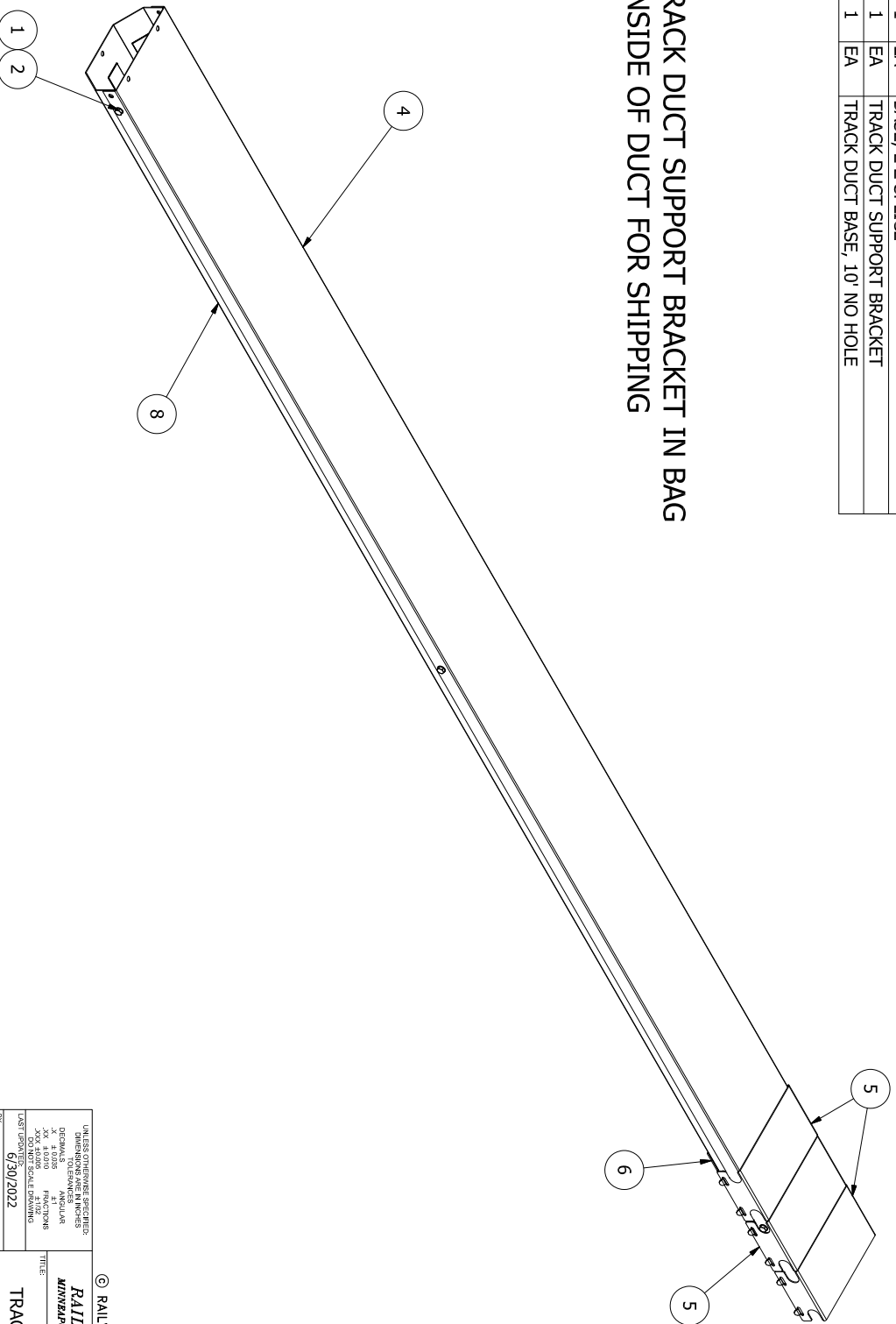

UNLESS OTHERWISE SPECIFIED:
 DIMENSIONS ARE IN INCHES
 DECIMALS ANGULAR
 FRACTIONS
 .000 NOT SCALE DRAWING

DATE: 6/30/2022
 BY: gwanderson

MATERIAL: NA
 IDENTIFICATION: NA

SCALE: 1/8" = 1'-0"

DWG NO: 9278-1201N
 TOW SIZE: B

REV: N

TITLE: TRACK DUCT SECTION, MID

© RAILWAY EQUIPMENT CO. 2020
 RAILWAY EQUIPMENT CO.
 MINNEAPOLIS, MINNESOTA (763) 978-2200

REV	ECO #	DESCRIPTION	DATE	BY
M	05-0047	NEW SUPPORT ASSEM. DESIGN	10/27/2005	RO
-	-	ADDED PN R9278-1202M	11/18/2020	CA
N	22-054	UPDATED SHEET METAL	6/30/2022	CA

ITEM	PART NUMBER	REV	QTY	UOM	DESCRIPTION
1	2600979300	-	11	EA	NUT, 1/4-20, CLIP ON, STEEL, BLACK PHOSPHATE
2	29051	-	11	EA	BOLT, 1/4-20 X 1/2 WITH 1/2 HD
3	6093-0100	-	1	EA	CABLE TIE, 4IN 0.10 WIDTH
4	92741F	F	1	EA	TRACK DUCT COVER, 10'
5	927441C	C	3	EA	CENTER COVER, E Z SPLICE
6	927450B	B	1	EA	BASE, E Z SPLICE
7	92774K	K	1	EA	TRACK DUCT SUPPORT BRACKET
8	9278-2740A	A	1	EA	END PLATE, TRACK DUCT
9	92785E	E	1	EA	DEFLECTOR, TRACK DUCT SML
10	9528-0538A	A	1	EA	TRACK DUCT BASE, 10' NO HOLE
11	ID9278-1202N	N	1	EA	LABEL, TRACK DUCT SECTION, HEEL

REVISION HISTORY

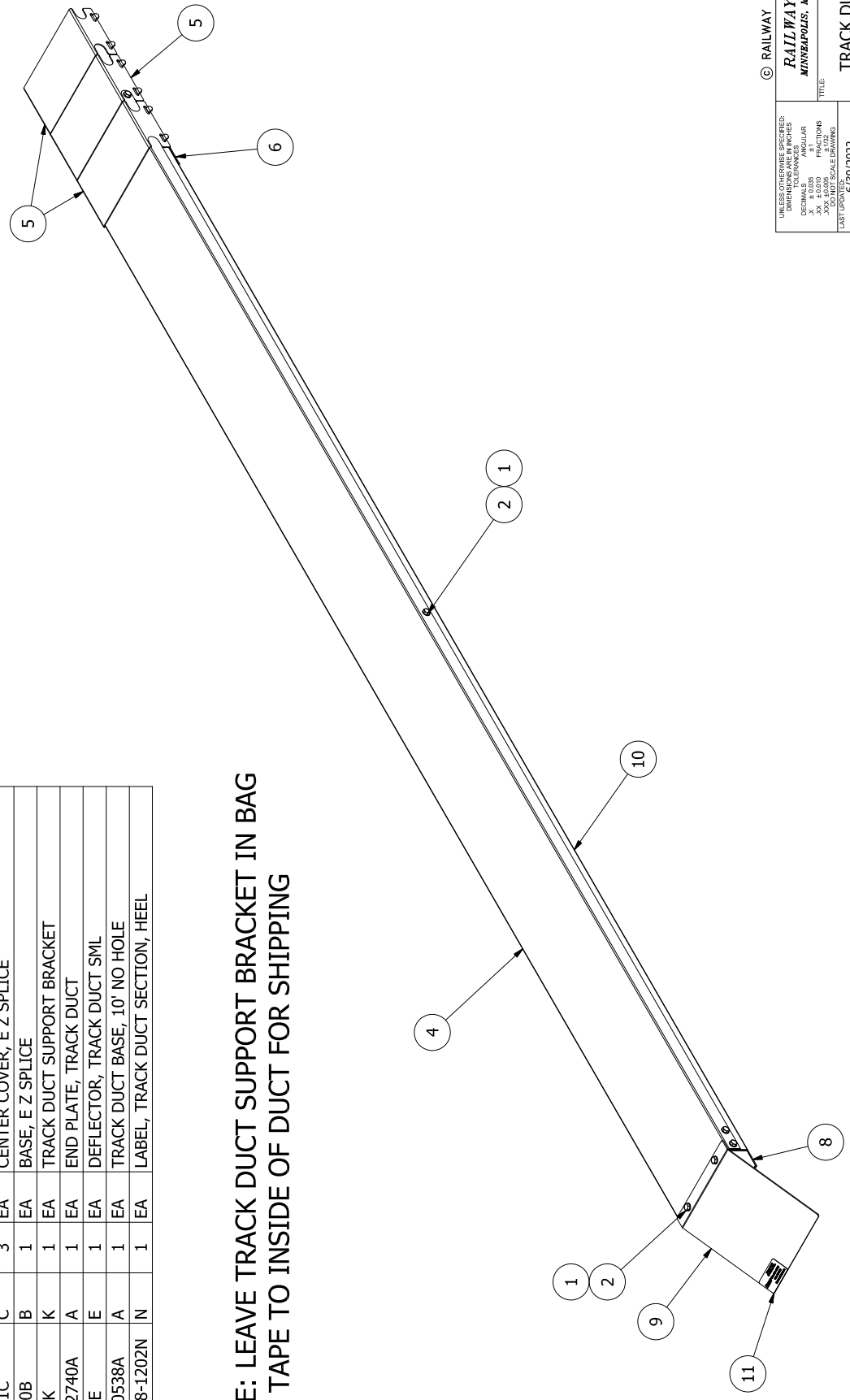

NOTE: LEAVE TRACK DUCT SUPPORT BRACKET IN BAG AND TAPE TO INSIDE OF DUCT FOR SHIPPING

UNLESS OTHERWISE SPECIFIED:
 DIMENSIONS IN INCHES
 DECIMALS TO TWO PLACES
 ANGULAR TO NEAREST 5'
 FRACTIONS TO NEAREST 1/16"
 TOLERANCES UNLESS OTHERWISE SPECIFIED:
 .XX ±0.010
 .XX ±0.015
 .XX ±0.020
 .XX ±0.030
 .XX ±0.040
 .XX ±0.050
 .XX ±0.060
 .XX ±0.070
 .XX ±0.080
 .XX ±0.090
 .XX ±0.100
 .XX ±0.125
 .XX ±0.150
 .XX ±0.1875
 .XX ±0.250
 .XX ±0.3125
 .XX ±0.375
 .XX ±0.4375
 .XX ±0.500
 .XX ±0.625
 .XX ±0.750
 .XX ±0.875
 .XX ±1.000
 .XX ±1.250
 .XX ±1.500
 .XX ±1.875
 .XX ±2.000
 .XX ±2.500
 .XX ±3.000
 .XX ±3.750
 .XX ±4.500
 .XX ±5.000
 .XX ±6.000
 .XX ±7.500
 .XX ±9.000
 .XX ±10.000
 .XX ±12.500
 .XX ±15.000
 .XX ±18.750
 .XX ±20.000
 .XX ±25.000
 .XX ±30.000
 .XX ±37.500
 .XX ±45.000
 .XX ±50.000
 .XX ±60.000
 .XX ±75.000
 .XX ±90.000
 .XX ±100.000
 .XX ±125.000
 .XX ±150.000
 .XX ±187.500
 .XX ±200.000
 .XX ±250.000
 .XX ±300.000
 .XX ±375.000
 .XX ±450.000
 .XX ±500.000
 .XX ±600.000
 .XX ±750.000
 .XX ±900.000
 .XX ±1000.000
 .XX ±1250.000
 .XX ±1500.000
 .XX ±1875.000
 .XX ±2000.000
 .XX ±2500.000
 .XX ±3000.000
 .XX ±3750.000
 .XX ±4500.000
 .XX ±5000.000
 .XX ±6000.000
 .XX ±7500.000
 .XX ±9000.000
 .XX ±10000.000

DATE: 6/30/2022
 BY: cwanderson
 MATL: NA
 BEND ALLOWANCE: NA
 SCALE: 1/8
 DWS SIZE: B
 SHEET: 1 OF 1

© RAILWAY EQUIPMENT CO. 2020
RAILWAY EQUIPMENT CO.
 MINNEAPOLIS, MINNESOTA (763) 972-2200

TRACK DUCT SECTION, HEEL

ITEM	PART NUMBER	REV	UOM	QTY	DESCRIPTION
1	14045	-	EA	1	BAG, 12 X 15 MIL ZIPTOP
2	1491-0704	-	EA	3	CONDUIT 2IN RIGID 2 HOLE STRAP
3	2600979300	-	EA	12	NUT, 1/4-20, CLIP ON, STEEL, BLACK PHOSPHATE
4	26039	-	EA	2	CAP, PLASTIC, 2IN TAPERED
5	28106	-	EA	4	SPACER, .38X.625X.375 ROUND
6	2832-8101	-	EA	4	NUT, 3/8-16 HEX
7	2833-8110	-	EA	4	WASHER, 3/8 FLAT
8	2833-8210	-	EA	4	WASHER, 3/8 SPLIT LOCK
9	2833-9015B	B	EA	4	WASHER, ISOLATING NOZZLE
10	29024	-	EA	6	BOLT, 1/4 X 1-1/2 LAG HEX
11	29051	-	EA	22	BOLT, 1/4-20 X 1/2 WITH 1/2 HD
12	32016	-	SOFT	.08	GASKET MATERIAL, 1/4" BLACK SILICONE RUBBER
13	600101	-	FT	1	HOSE, 2IN UNLINED INTERLOCKED GALVANIZED STEEL 12' 6" LONG EACH PIECE
14	60195	-	FT	1.67	GASKET, .25 X 1.0 ADHESIVE BK
15	927155A	A	EA	1	WELDMT, END PLATE, TRACK DUCT
16	92747C	C	EA	1	TRACK DUCT BOTTOM SECTION
17	92749	A	EA	2	CAP, STEEL, 2IN ID
18	92753B	B	EA	1	COVER, TOP TRACK DUCT
19	927588B	B	EA	1	NOZZLE, TRACK DUCT, NO DAMPER
20	92759	B	EA	1	GASKET, ISO, TR NOZZLE RED
21	927604	B	EA	1	TRACK DUCT NOZZLE MOUNT PLATE
22	92760B	B	EA	1	DEFLECTOR, TRACK DUCT TUBE
23	927702	A	EA	1	SCREEN TRACK DUCT NOZZLE LARGE
24	9278-2740A	A	EA	1	END PLATE, TRACK DUCT
25	92785E	E	EA	1	DEFLECTOR, TRACK DUCT SML
26	R9278-9500D	D	EA	1	LABEL, ID

Parts List

REV	ECO #	DESCRIPTION	DATE	BY
C	-	NOZZLE ASSEMBLY CHANGED	9/25/15	BF
D	-	SHORTENED NOZZLE	3/11/16	BF
-	22-054	92740F TO 9278-2740A	6/30/2022	CA

REVISION HISTORY

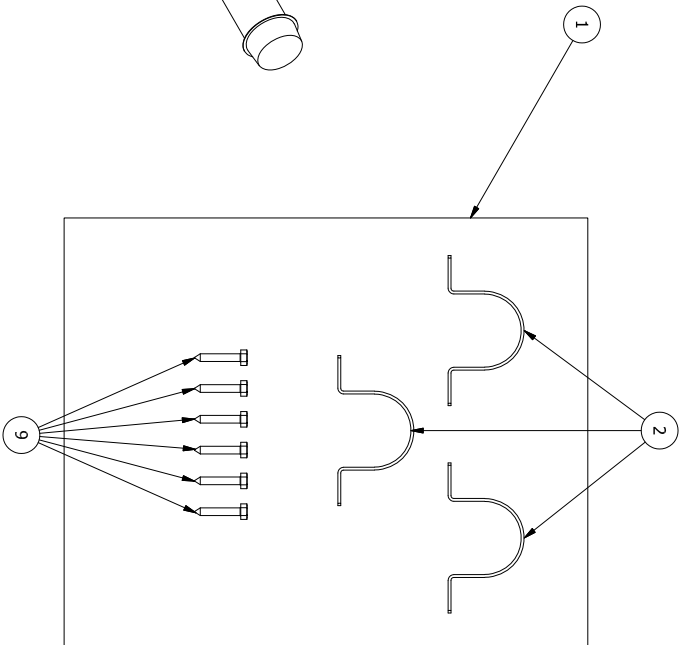

© RAILWAY EQUIPMENT CO. 2006

UNLESS OTHERWISE SPECIFIED:
 DIMENSIONS ARE IN INCHES
 DECIMALS ANGULAR
 .XX 4 0010 FRACTIONS
 .XX NOT SCALE DRAWING
 DRAWN: BF
 DATE: 3/11/16
 WRT: N/A
 TEND: N/A
 N/A

RAILWAY EQUIPMENT CO.
 DELANO, MINNESOTA (763) 972-4200

TITLE: FLEX NOZZLE KIT (LTD)

DWG NO: 9278-9500D
 SCALE: 1:4
 DWG SER: B
 SHEET 1 OF 3

REV: D

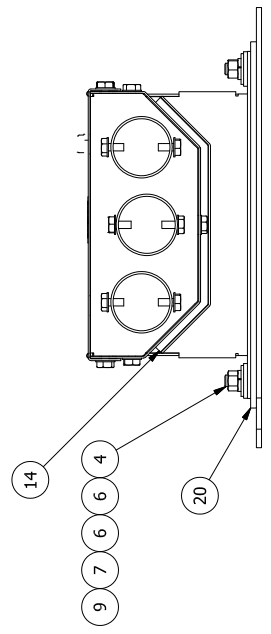
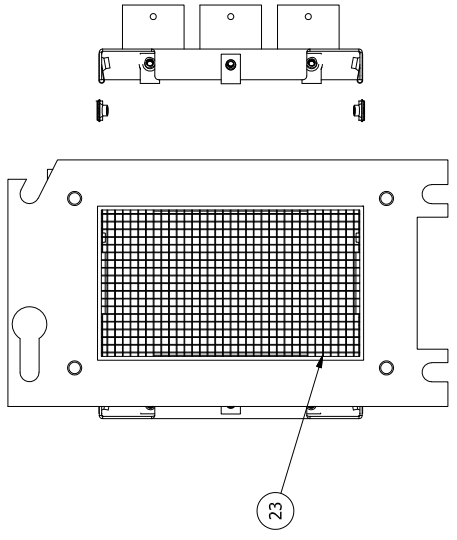
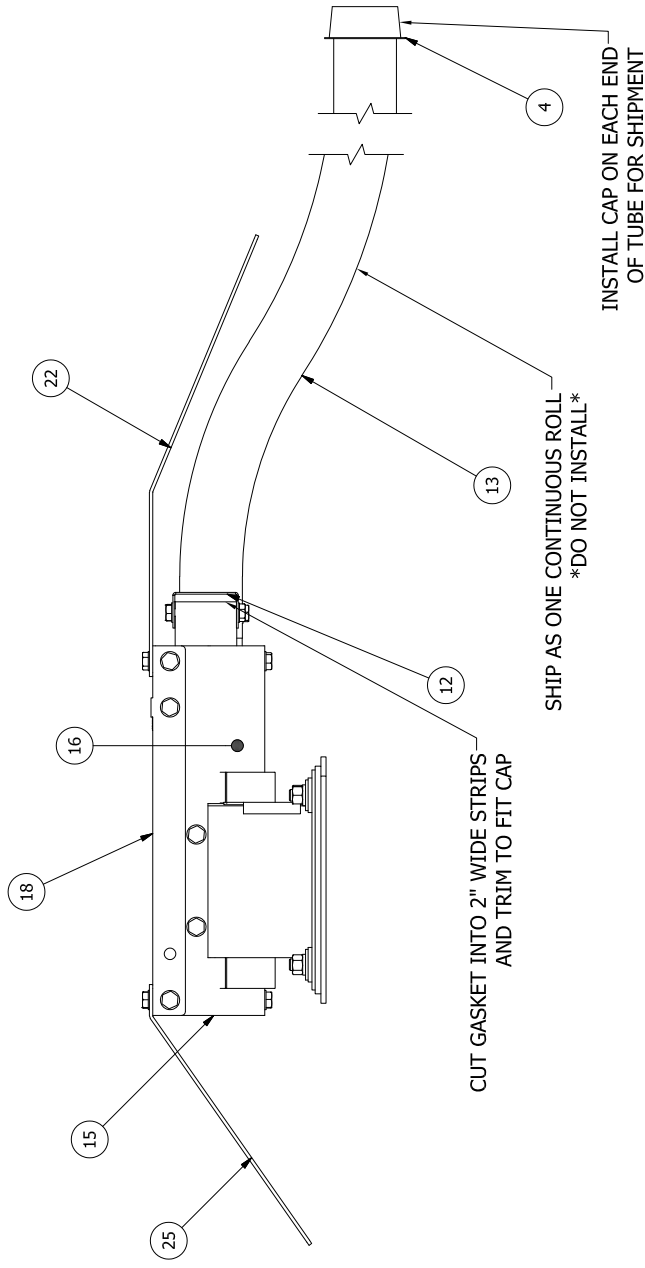
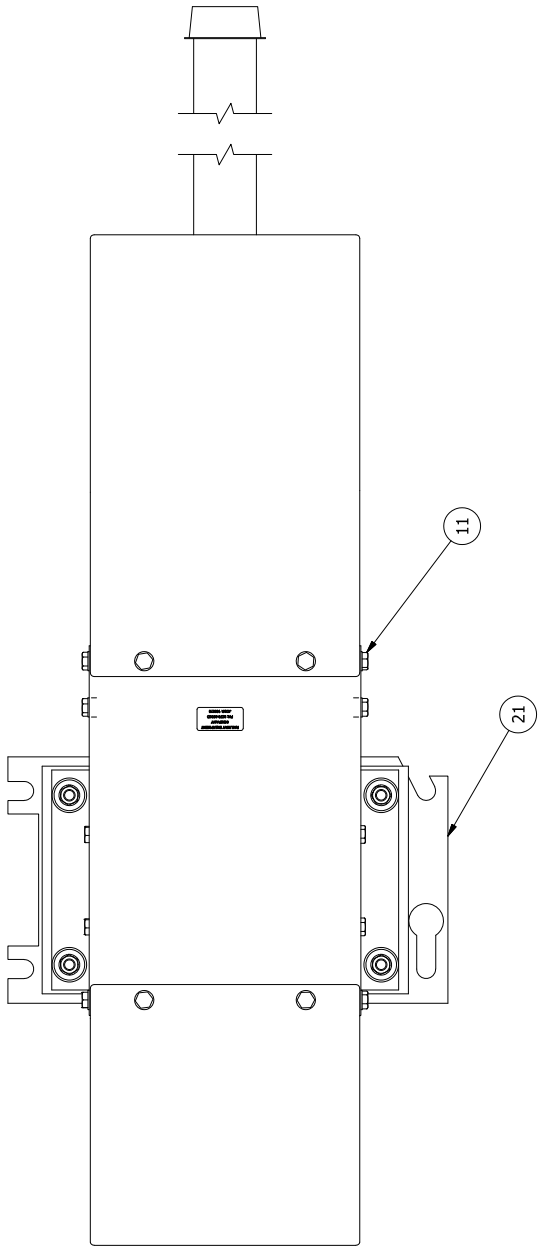

UNLESS OTHERWISE SPECIFIED:
DIMENSIONS ARE IN INCHES
DECIMALS - FRACTIONS
.XX - 1/16
.XX - 1/8
FRACTIONS
DO NOT SCALE DRAWING

DRAWN: BF

DATE: 3/11/16

NOTED

SCALE: N/A

© RAILWAY EQUIPMENT CO. 2006

RAILWAY EQUIPMENT CO.
DELANO, MINNESOTA (763) 978-2800

TITLE: FLEX NOZZLE KIT (LTD)

DWG NO: 9278-9500D

REV: D

SCALE: 1/4

DWG SIZE: B

SHEET 2 OF 3

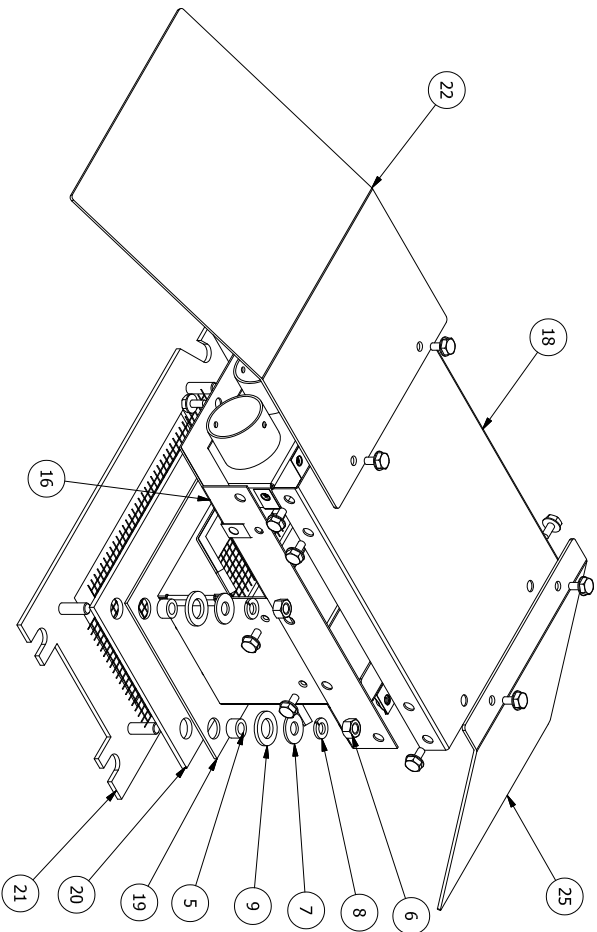
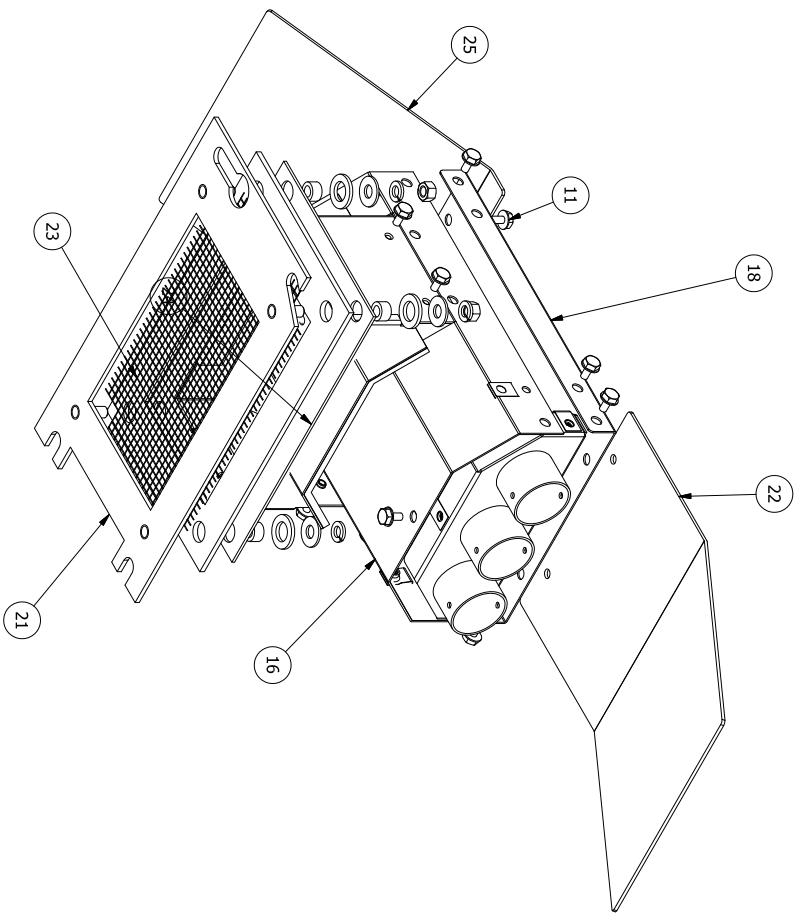

© RAILWAY EQUIPMENT CO. 2006

UNLESS OTHERWISE SPECIFIED:		DIMENSIONS ARE IN INCHES	
DECIMALS		ANGULAR	
.XX		4.000	
FRACTIONS		32	
DRAWING BY		SCALE DRAWING	
DATE: 4/6/16			
WARRANTY: N/A			
TOLERANCE:			
N/A			
DRAWING NO:		9278-9500D	
SCALE:		B	
SHEET:		3 OF 3	
REV:		D	
<p>RAILWAY EQUIPMENT CO. DELANO, MINNESOTA (763) 972-4200</p> <p>FLEX NOZZLE KIT (LTD)</p>			

PARTS LIST					
ITEM	PART NUMBER	REV	UOM	QTY	DESCRIPTION
1	12425	-	IN	108	TAPE ROLL 2 INCH WIDE HEAVY
2	2600979300	-	EA	26	NUT, 1/4-20, CLIP ON, STEEL, BLACK PHOSPHATE
3	29051	-	EA	26	BOLT, 1/4-20 X 1/2 WITH 1/2 HD
4	6093-0100	-	EA	3	CABLE TIE, 4IN 0.10 WIDTH
5	92741F	F	EA	3	TRACK DUCT COVER, 10'
6	927441C	C	EA	6	CENTER COVER, E Z SPLICE
7	927450B	B	EA	2	BASE, E Z SPLICE
8	92774K	K	EA	3	TRACK DUCT SUPPORT BRACKET
9	9278-2740A	A	EA	2	END PLATE, TRACK DUCT
10	92785E	E	EA	2	DEFLECTOR, TRACK DUCT SML
11	9528-0538A	A	EA	2	TRACK DUCT BASE, 10" NO HOLE
12	9528-0539A	A	EA	1	TRACK DUCT BASE, 10" W/HOLE
13	R9278-0233C	C	EA	1	LABEL, 30" TRACK DUCT

REVISION HISTORY				
REV	ECO #	DESCRIPTION	DATE	BY
B	10-012	NEW PART	6/01/10	RH
-	-	PN 927442 TO 927441B	9/29/2020	CA
C	22-054	UPDATED SHEET METAL	6/27/2022	CA

3D VIEW

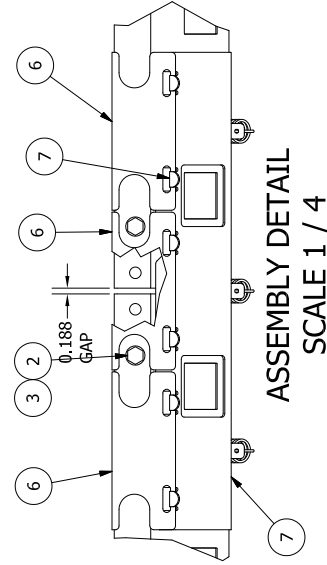
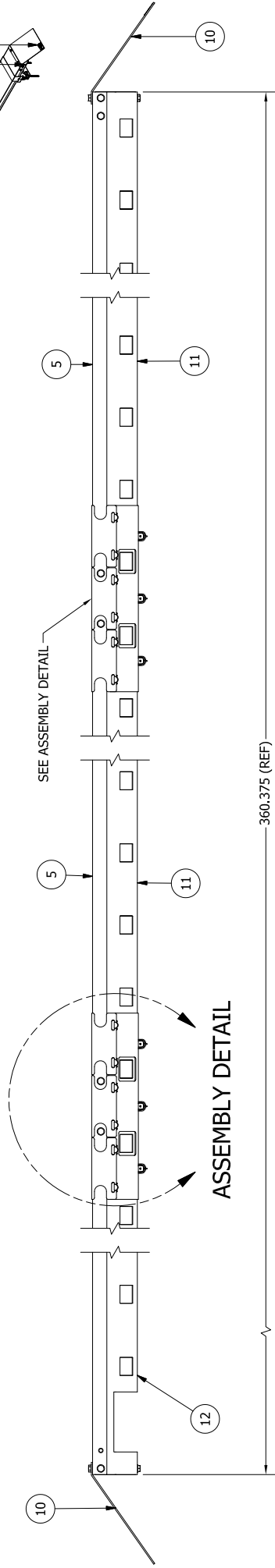
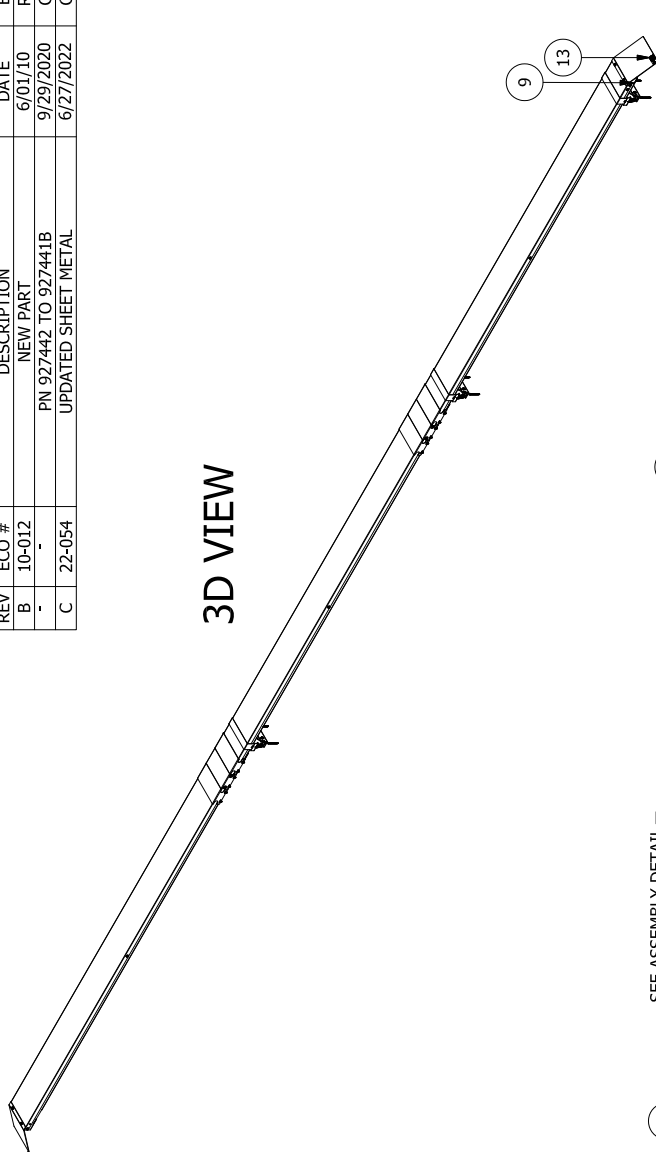

ASSEMBLY DETAIL
SCALE 1 / 4

UNLESS OTHERWISE SPECIFIED:
DIMENSIONS ARE IN INCHES
DECIMALS AND ANGULAR
DIMENSIONS TO 0.010
FRACTIONS TO 1/16"
DIMENSIONS IN PARENT
DIMENSIONS IN PARENT
DIMENSIONS IN PARENT
DIMENSIONS IN PARENT

© RAILWAY EQUIPMENT CO. 2020
RAILWAY EQUIPMENT CO.
DELANO, MINNESOTA (763) 972-2200

TITLE: TRACK DUCT 30"
WIDE TO NOZZLE/10' SECTIONS
(ASSEMBLY / B. O. M.)

DATE: 11/16/2009
DWG NO: 9278-0233C
REV: C

SCALE: 1 : 8
DWSIZE: B
SHEET 1 OF 1

ITEM	PART NUMBER	REV	QTY	UOM	DESCRIPTION
1	14045	-	1	EA	BAG, 12 X 15 4MIL ZIPTOP
2	2600976100	-	2	EA	LAG BOLT, 5/16 X 4, WASHER HEAD, 6 LOBE DRIVE, STEEL, COATED
3	2831551110	-	2	EA	BOLT, 1/4-20 X 5/8 HEX HEAD
4	2832-5901	-	2	EA	NUT, 1/4-20 CENTERLOCK
5	92742B	B	2	EA	SPRING, TRACK DUCT SUPPORT
6	92743	B	2	EA	CLIP, HOLDDOWN SPRING
7	92745	A	1	EA	HOLDDOWN STRAP, T. DUCT
8	927550C	C	1	EA	TRACK DUCT SUPPORT BASE
9	927551	A	1	EA	TRACK DUCT SPRING BRKT NARROW
10	R92774K	-	1	EA	LABEL, TRACK DUCT BRACKET

PARTS LIST

REV	ECO #	DESCRIPTION	DATE	BY
J	05-0017	NEW SPLICE SYSTEM	5/18/2005	RF
K	05-0047	SHORTENED 927550-551 PN 927550B TO C	10/27/2005	RO
-	-	REMOVED PN 14042	1/20/2020	CA
-	-		4/9/2020	CA

REVISION HISTORY

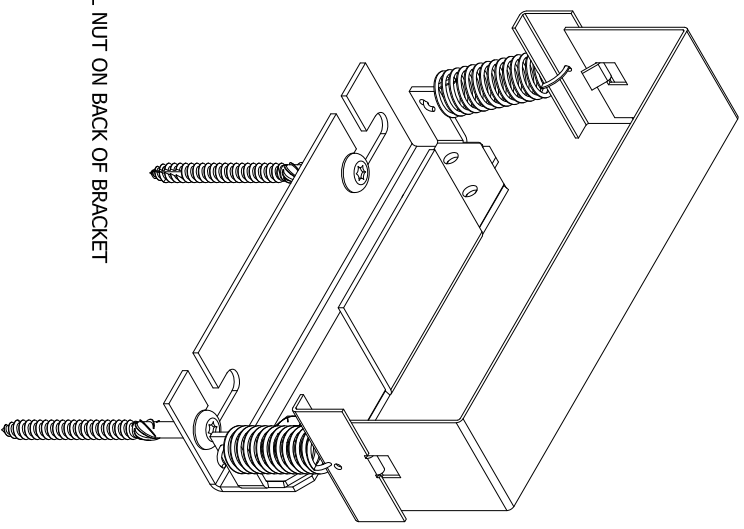
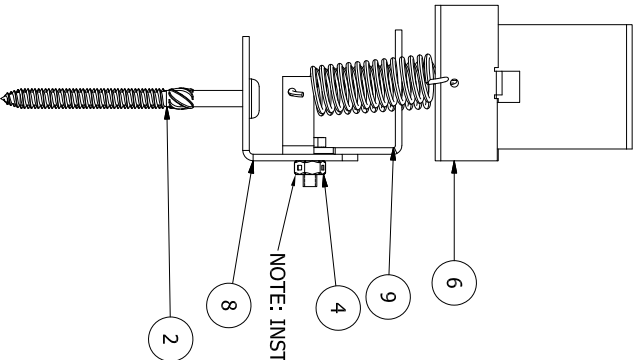
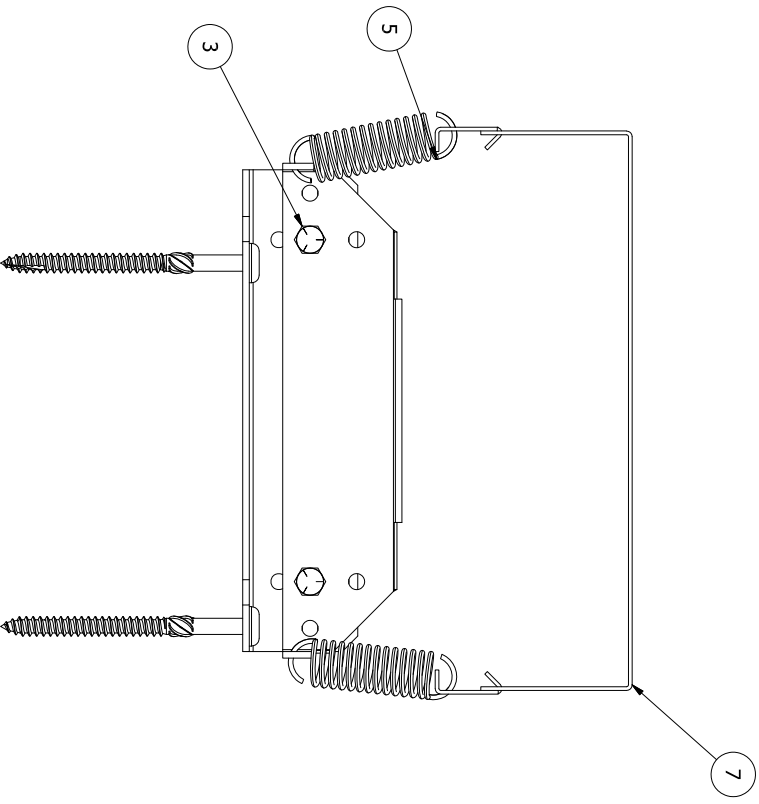

NOTE: DO NOT FULLY TIGHTEN NUT, ONLY SNUG UP

© RAILWAY EQUIPMENT CO. 2020

UNLESS OTHERWISE SPECIFIED:
DIMENSIONS ARE IN INCHES
DECIMALS ANGULAR
XX 1/16 1/32 FRACTIONS
X .000 NOT SCALE DRAWING

DATE: 9/10/2020
BY: gwandersen

DATE: 9/10/2020
BY: gwandersen

MATERIAL: NA
FINISH: NA

DWG NO: 92774K
SCALE: 1/2" = 1"
TOW SIZE: B
SHEET 1 OF 1

RAILWAY EQUIPMENT CO.
MINNEAPOLIS, MINNESOTA (763) 978-2200

TRACK DUCT SUPPORT BRACKET

REV: K

REVISION HISTORY				
REV	ECO #	DESCRIPTION	DATE	BY
A	-	NEW PART	12/12/2003	RF
B	05-0005	ADDED BULKHEAD TO BLOWER	06/09/2005	IW
C	05-0005	ADD ELBOW/NIPPLE 9528-0027	01/31/2012	MP

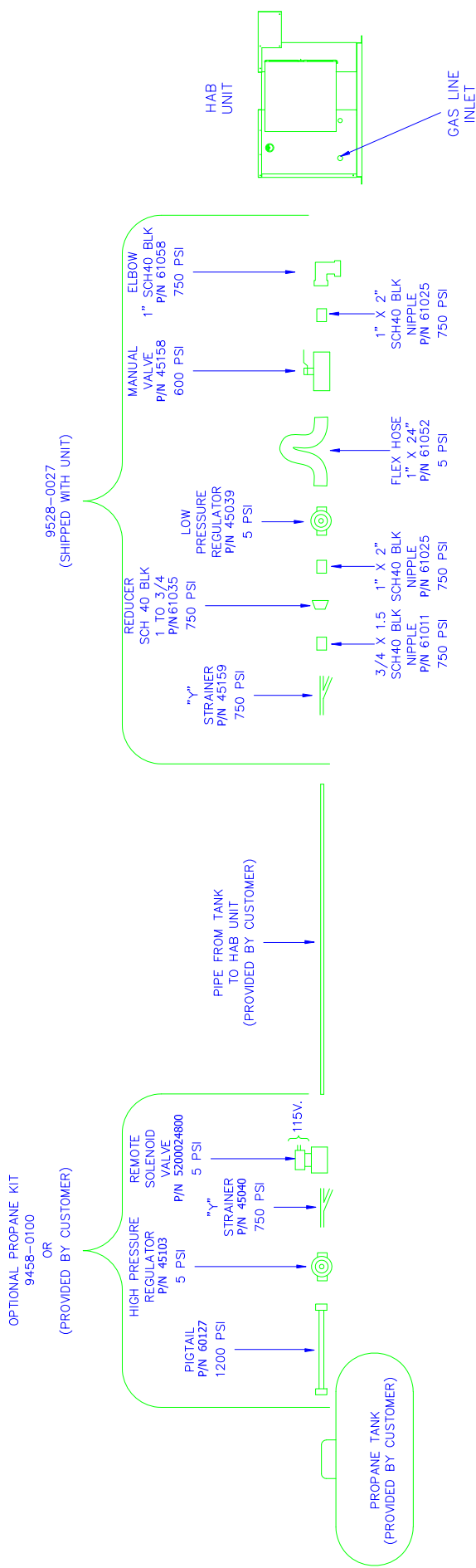

UNLESS OTHERWISE SPECIFIED: DIMENSIONS ARE IN INCHES DIMENSIONS IN PARENTHESES DECIMALS ARE IN THOUSTHS .XX = 0.0010 .XXX = 0.0005 FRACTIONS XX/XX = 1/XX XX/XX = 1/XX DO NOT SCALE DRAWING		© RAILWAY EQUIPMENT CO. 2020	
RAILWAY EQUIPMENT CO. MINNEAPOLIS, MINNESOTA (763) 972-2200		DRAWING NO. R9520-0027C	
TITLE: GAS HOT AIR BLOWER, GAS LINE LAYOUT		SCALE: DWG SIZE: B	
DATE: 2/11/2020	BY: akollman	REV: R9520-0027C	SHEET 1 OF 1
MATERIAL: NA		REVISIONS: NA	

ITEM	PART NUMBER	REV	UOM	QTY	DESCRIPTION
1	21023	-	EA	1	STRAIN RELIEF, 3 POS
2	21212	-	EA	1	CONNECTOR HOUSING, 3 POS, 18GA
3	2831551134	-	EA	8	BOLT, 1/4-20 X 1-3/4 HEXTAP SS
4	2831551410	-	EA	2	BOLT, 1/4-20 X 3/8 HEX HEAD SS
5	2833-5115	-	EA	10	WASHER, 1/4 FLAT SS
6	2833-5241	-	EA	10	WASHER, 1/4 SPLIT LOCK SS
7	4100151600	-	EA	1	NIPPLE, 1/4"X4.5" SCH 80
8	4100153000	-	EA	1	NIPPLE, BLACK 1" X 7" SCH 40
9	45035	-	EA	1	VALVE, K3A552, 0.3PSI GAS
10	45155	-	EA	2	VALVE, COMBUSTION
11	60002	-	EA	5	3/8 ROMEX BRIDGEPORT# 650-DC2
12	60011	-	EA	1	CONNECTOR, CONRD 1/2INCH STRT
13	60160	-	EA	1	CONDUIT, LOCK NUT 1/2 IN
14	60197	-	EA	1	FLEX HOSE 3/4 X 18 - 5/8 OD
15	60226	-	EA	1	TEE, 1 X 1 X 3/4 SCH 40
16	60231	-	EA	4	O-RING, BUNA-N, 3/16 WIDE
17	60234	-	EA	1	TEE, 3/4 X 3/4 X 1/4 SCH 40 BLK
18	60241	-	IN	104	CABLE, 4 COND, 18GA PVC
19	6032-0120	-	EA	1	LUG, RINGS 1/4 22-18GA VINYL
20	6092-0201	-	EA	9	LUG, WIRE JOINT NYLON SMALL, 122 ID
21	6093-0100	-	EA	2	CABLE TIE, 4IN.0.10 WIDTH
22	61001	-	EA	2	ELBOW, 3/4IN SCH 40 BLACK
23	61011	-	EA	2	NIPPLE, 3/4 X 1.5 SCH 40 BLACK
24	61012	-	EA	2	NIPPLE, 3/4 X 2 SCH 40 BLACK
25	61013	-	EA	1	NIPPLE, 3/4 X 3 SCH 40 BLACK
26	61023	-	EA	1	NIPPLE, 1 X 6 IN SCH 40 BLACK
27	61025	-	EA	1	NIPPLE, 1 X 2 IN SCH 40 BLACK
28	61027	-	EA	1	CAP, PIPE 1 IN SCH 40 BLACK
29	61067	-	EA	1	NIPPLE, 1 X 3.5 IN SCH 40 BLACK
30	61072	-	EA	1	COUPLING, 1/4IN SCH 80
31	681820	-	FT	1.5	CORD, STRAIGHT, 18/2 SJTOW
32	9336120	-	EA	1	COUPLING PLATE 3/4 NPT
33	9338-0043A	-	EA	3	SNIBBER ASSEMBLY, GAS VALVE
34	9338-0070C	-	EA	1	ASSY, GAS PRESSURE SENSOR
35	953611A	-	EA	1	OUTLET MANIFOLD, GAS LINE 3/6HP
36	953612A	-	EA	1	COUPLING PLATE 1 INCH NPT
37	953620C	-	EA	1	UNIVERSAL ORIFICE PLATE 5HP
38	R9528-0237C	-	EA	1	LABEL, GHAB GAS PIPING W/PRESS SENSOR 5 HP W/MANIFOLD

Parts List

NOTE:
 1. USE LOCTITE 401 SEALANT TO INSTALL THE FOUR O-RINGS INTO THE OUTLET MANIFOLD AND THE COUPLING PLATES. DO NOT USE LOCTITE BETWEEN THE O-RINGS AND THE ORIFICE PLATE.
 2. WATCH THE GAS FLOW DIRECTION WHEN INSTALLING THE GAS VALVES.

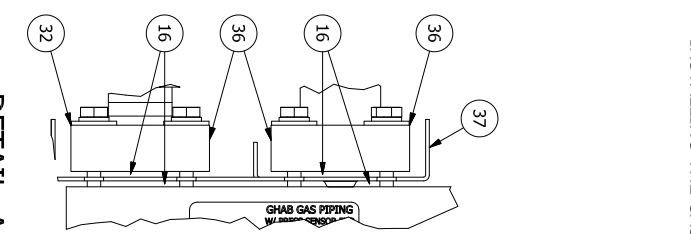

DETAIL A
SCALE 1 / 2

GAS VALVE WIRING DIAGRAM

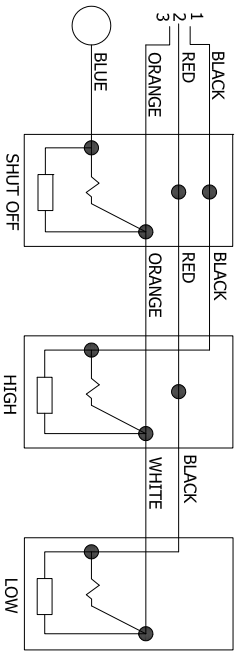

REVISION HISTORY				
REV	ECO	DESCRIPTION	DATE	BY
A	06-0027	NEW PART	10/9/2006	RMJ
B	07-0016	CHANGE CONDUIT TO CONRD ADD COVER	6/6/07	RMJ
C	07-0024	UPDATED TO U BOLT	8/6/07	WIS
D	-	ADDED ELBOWS	03/19/2021	AK

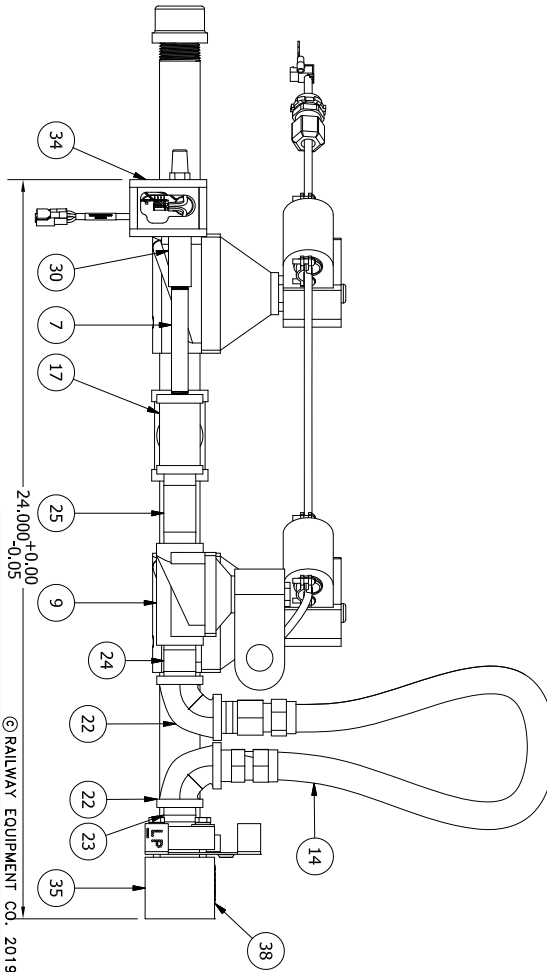
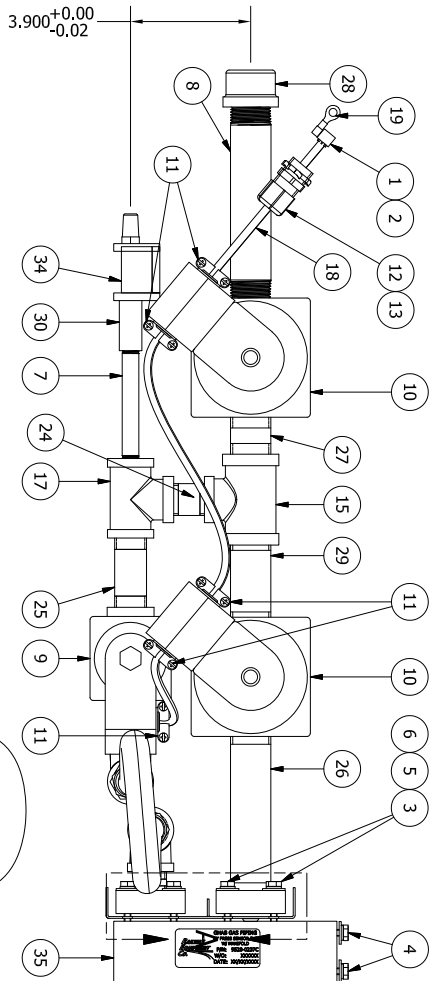

© RAILWAY EQUIPMENT CO. 2019

UNLESS OTHERWISE SPECIFIED:
 DIMENSIONS ARE IN INCHES
 DECIMALS TO ANGULAR
 XX, 4 0.02" FRACTIONS
 30.000 SCALE DRAWING
 DRAWN: TBERTOLDI
 DATE: 4/9/2019
 DWG NO: 9528-0237D
 TITLE: GHAB GAS PIPING W/ PRESSURE SENSOR
 SHP HIGH PROFILE
 SCALE: 1/4" = 1"
 DWG SER: B
 SHEET 1 OF 1

REVISION HISTORY				
REV	ECO #	DESCRIPTION	DATE	BY
A	-	NEW PART	4/5/2016	BF
-	-	ADDED PLASTIC CONNECTOR	12/20/2018	JRG

PARTS LIST					
ITEM	PART NUMBER	REV	QTY	UOM	DESCRIPTION
1	14500	-	1	EA	MAGNET, CIRCULAR SHIELDED
2	16003	-	0.1	OZ	RTV SILICONE CLEAR 10 OZ TUBE
3	2831311106	-	1	EA	SCREW, #8-32 X 3/8 PAN SLT
4	2832-3103	-	1	EA	NUT, #8-32 SHORT NYLON LOCKNUT
5	2833-3110	-	1	EA	WASHER, #8 FLAT SAE
6	31217	-	1	EA	CONNECTOR, HOUSIN THERMOCOUPLE
7	60051	-	2	EA	CONNECTOR, CORD 1/2INCH STRT
8	60160	-	2	EA	CONDUIT, LOCK NUT 1/2 IN
9	60203	-	1.25	IN	HEATSHRINK, TUBING HIGH TEMP
10	60275	-	5	FT	CONDUIT, 10MM OD HIGH TEMP
11	681844	-	82	IN	WIRE, THERMOCOUPLE TYPE T 500F PFA
12	9000-0404A	A	1	EA	AMBIENT TEMP SENSOR BRACKET
13	R9508-0404A	A	1	EA	LABEL, AIR TEMP SENSOR MAGNETIC

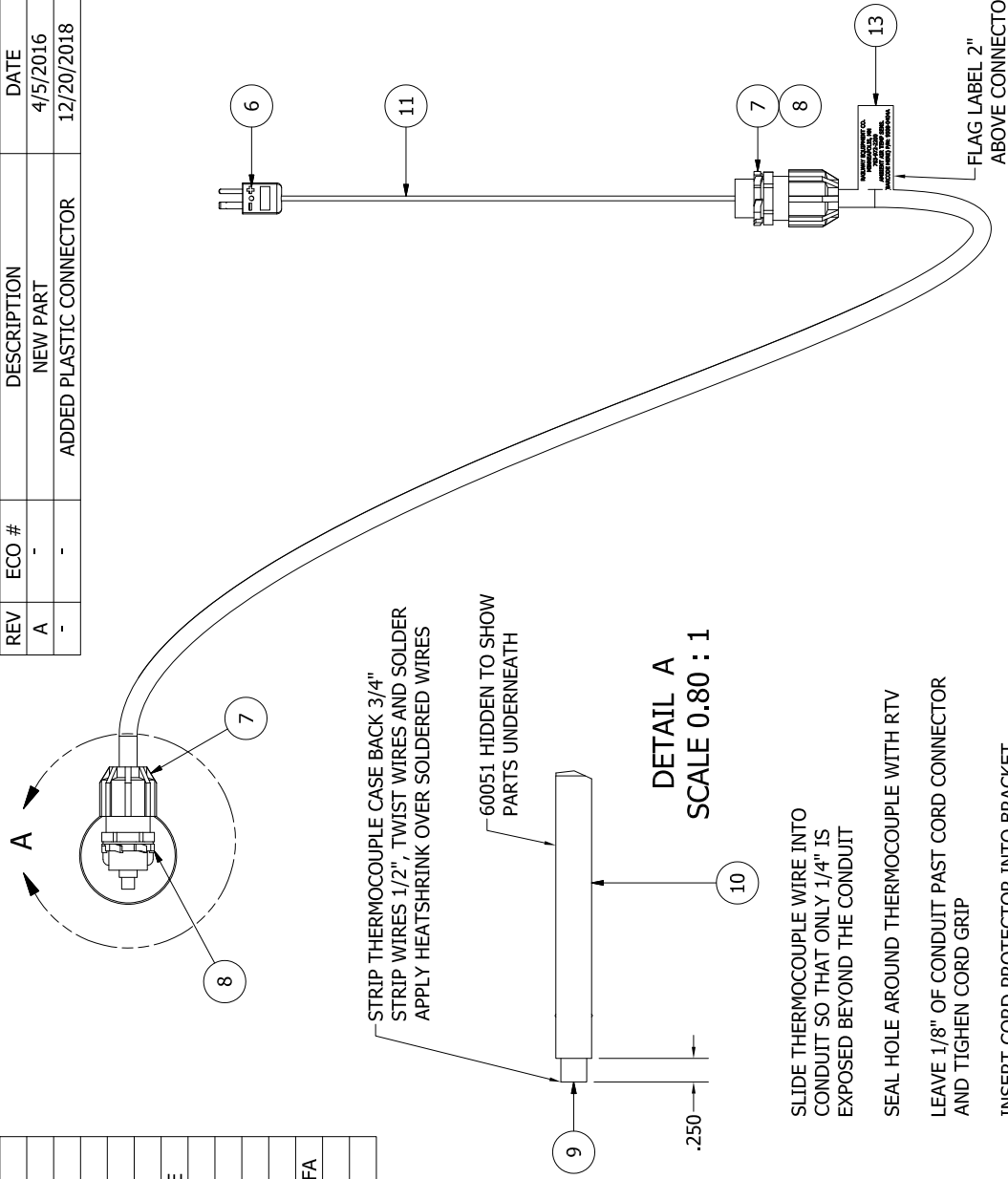

STRIP THERMOCOUPLE CASE BACK 3/4"
STRIP WIRES 1/2", TWIST WIRES AND SOLDER
APPLY HEATSHRINK OVER SOLDERED WIRES

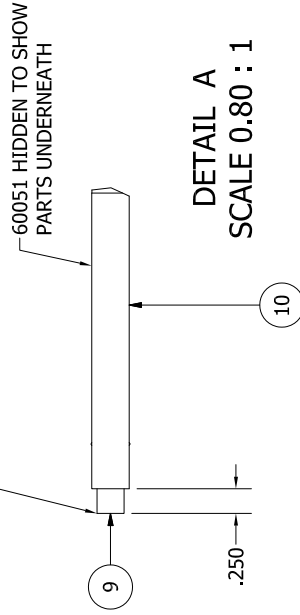

DETAIL A
SCALE 0.80 : 1

SLIDE THERMOCOUPLE WIRE INTO
CONDUIT SO THAT ONLY 1/4" IS
EXPOSED BEYOND THE CONDUIT

SEAL HOLE AROUND THERMOCOUPLE WITH RTV

LEAVE 1/8" OF CONDUIT PAST CORD CONNECTOR
AND TIGHTEN CORD GRIP

INSERT CORD PROTECTOR INTO BRACKET
APPLY CONDUIT LOC NUT, TIGHTEN WITH
CHANNEL LOCKS

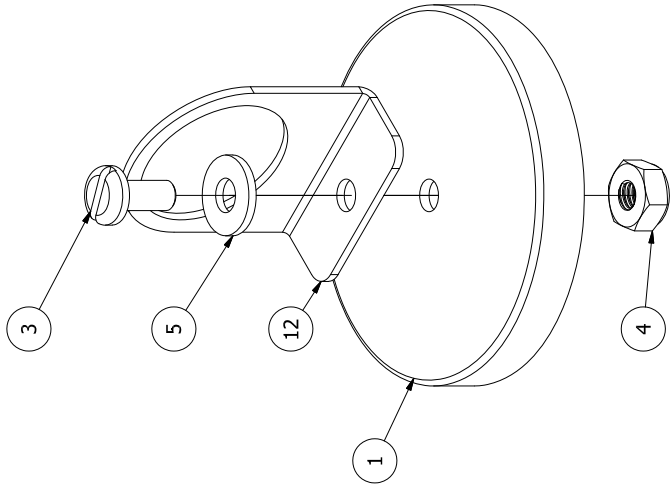

UNLESS OTHERWISE SPECIFIED: DIMENSIONS ARE IN INCHES DIMENSIONS IN PARENTHESES ARE IN MILLIMETERS		© RAILWAY EQUIPMENT CO. 2018
DECIMALS FRACTIONS ANGULAR DIMENSIONS TOLERANCES LAST UPDATED	RAILWAY EQUIPMENT CO. MINNEAPOLIS, MINNESOTA (763) 972-2200	
TITLE: AIR TEMPERATURE SENSOR 5' MAGNETIC		
DATE: 1/2/2020	BY: akollman	DWG NO.: 9508-0404A
MATERIAL: N/A	REVISION: A	SCALE: 2:1
BEND ALLOWANCE: N/A	DWG SIZE: B	SHEET: 1 OF 1

PARTS LIST

ITEM	PART NUMBER	REV	QTY	UOM	DESCRIPTION
1	2600949101	-	1	EA	SCREW, 10-32 X 1/2, HEX, SS
2	2831851112	-	4	EA	BOLT, 3/8-16 X 3/4 HEX HEAD
3	2832-4201	-	1	EA	NUT, #10-32 HEX SS
4	2832-8904	-	4	EA	NUT, 3/8-16 CENTERLOCK
5	2833-4310	-	1	EA	WASHER, #10 EXT. STAR
6	3000022400	-	1	EA	SPARK IGNITER, NGK 5464
7	3100115100	-	1	EA	LUG, PUSH-ON F, .250 14-16GA NON INSUL.
8	53070	-	1	EA	FLAME SENSOR, 7.5 INCH
9	6032-0118	-	1	EA	LUG, RING 1/4 16-14GA VINYL
10	61026	-	1	EA	NIPPLE, 1 X 4 IN SCH 40 BLACK
11	61028	-	1	EA	UNION, 1 IN SCH 40 BLACK
12	681402	-	3.5	FT	WIRE, 14GA HIGH TEMP
13	706894	-	1	EA	TERM, TAB, #10
14	952103	A	1	EA	SUPPORT BRKT, 12 IN BURNER
15	952140D	D	1	EA	BURNER WELDMENT, 12 INCH SS
16	R9528-0135C	-	1	EA	LABEL, BURNER, 12IN STAINLESS STEEL

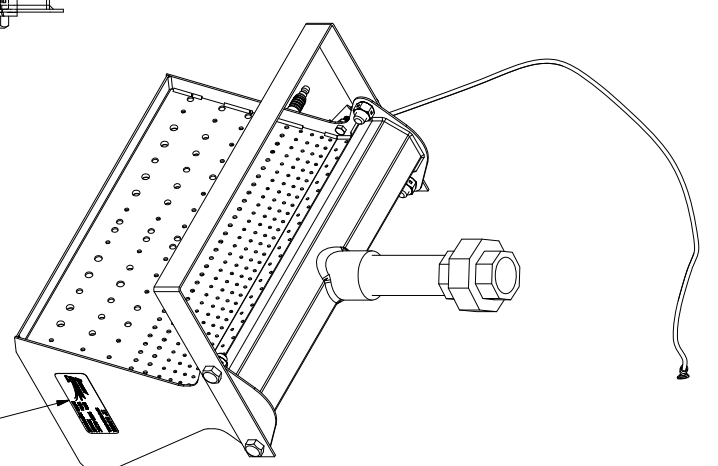
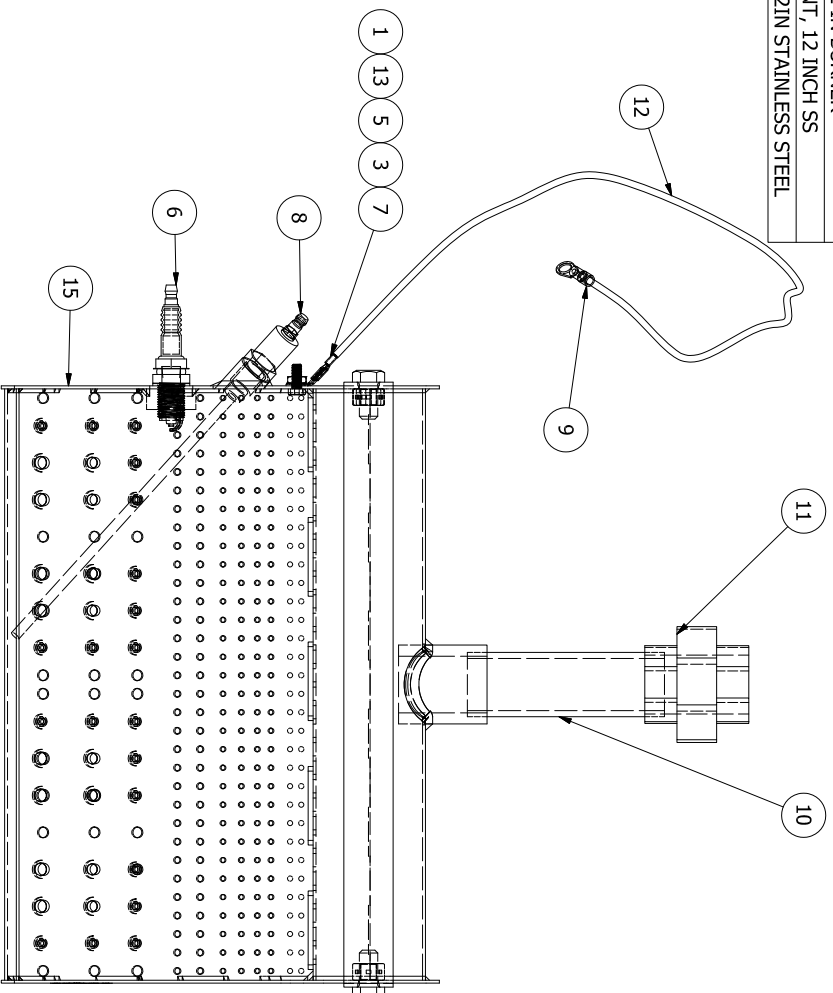
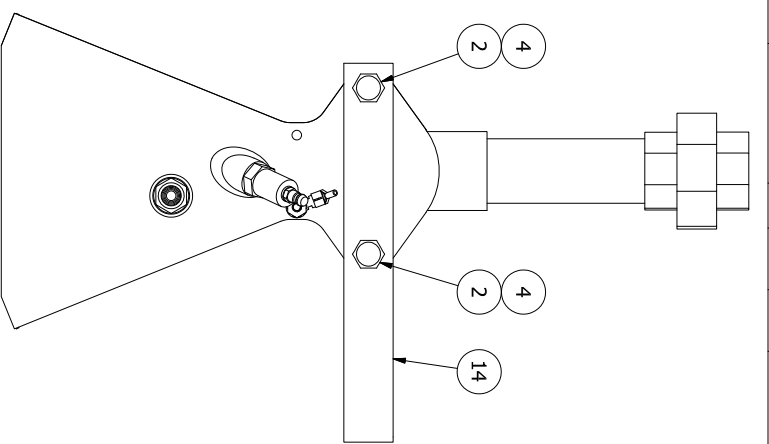

REVISION HISTORY			
REV	ECO #	DESCRIPTION	DATE
A	-	NEW PART	7/20/04
B	02-0024	NEW BURNER	7/20/04
C	18-0013	BURNER MATERIAL SS CHANGE	1/10/19
-	-	ADDED LABEL	6/29/2020

© RAILWAY EQUIPMENT CO. 2021

UNLESS OTHERWISE SPECIFIED:
 DIMENSIONS ARE IN INCHES
 DECIMALS ANGULAR
 .XX & .010 FRACTIONS
 .XX DO NOT SCALE DRAWING
 LAST REVISED 12/31/2020

TITLE: **BURNER, 12IN STAINLESS STEEL**

WFLY: NA
 akolman

DWG NO: **9528-0135C**

SCALE: 1/25 DWG SIZE: B SHEET 1 OF 1

RAILWAY EQUIPMENT CO.
 MINNEAPOLIS, MINNESOTA (763) 972-2200

REVISION HISTORY			
REV	ECO #	DESCRIPTION	DATE
A	17-0016	NEW PART	5/11/2018
-	-	REMOVED PN 32002	07/07/2020
-	21-011	CHANGED PN 9538-0039B TO 9508-0041B	3/18/2021

PARTS LIST					
ITEM	PART NUMBER	REV	QTY	UOM	DESCRIPTION
1	16003	-	0.05	EA	RTV SILICONE CLEAR 10 OZ TUBE
2	166000200	-	1	EA	FITTING, COMPRESSION 1/4" OD AIRLINE TO NPT 1/4" BRASS
3	166000300	-	1	EA	FITTING, 1/4" NPT RIGHT ANGLE TEE FM BRASS
4	2831411429	-	2	EA	SCREW, #10-32 X 1-3/4 PAN PHIL SS
5	60037	-	2	EA	BUSHING,ANTI-SHORT 3/4 IN FLEX
6	60061	-	3.5	FT	CONDUIT, FLEX 3/4 INCH STEEL
7	60071	-	1	EA	CONDUIT, FLEX CONNECTOR STRT 3/4 INCH STRAIGHT
8	60093	-	1	EA	CONDUIT, FLEX CONNECTOR 90
9	60168	-	88	IN	TUBING, 1/4INCH O.D. NYLON
10	6093-0100	-	4	EA	CABLE TIE, 4IN 0.10 WIDTH
11	61069	-	1	EA	MUFFLER / FILTER 1/4" BRASS
12	9338-0073A	A	1	EA	ASSY, DUCT PRESSURE SENSOR
13	9508-0041B	B	1	EA	ASSY, DUCT SENSOR EXT CABLE
14	952822B	B	1	EA	COVER, PRESSURE SENSOR 2 HP
15	952823A	A	1	EA	PLATE, PRESSURE SENSOR 3 AND 5 HP
16	R9538-0151A	A	1	EA	LABEL, ID

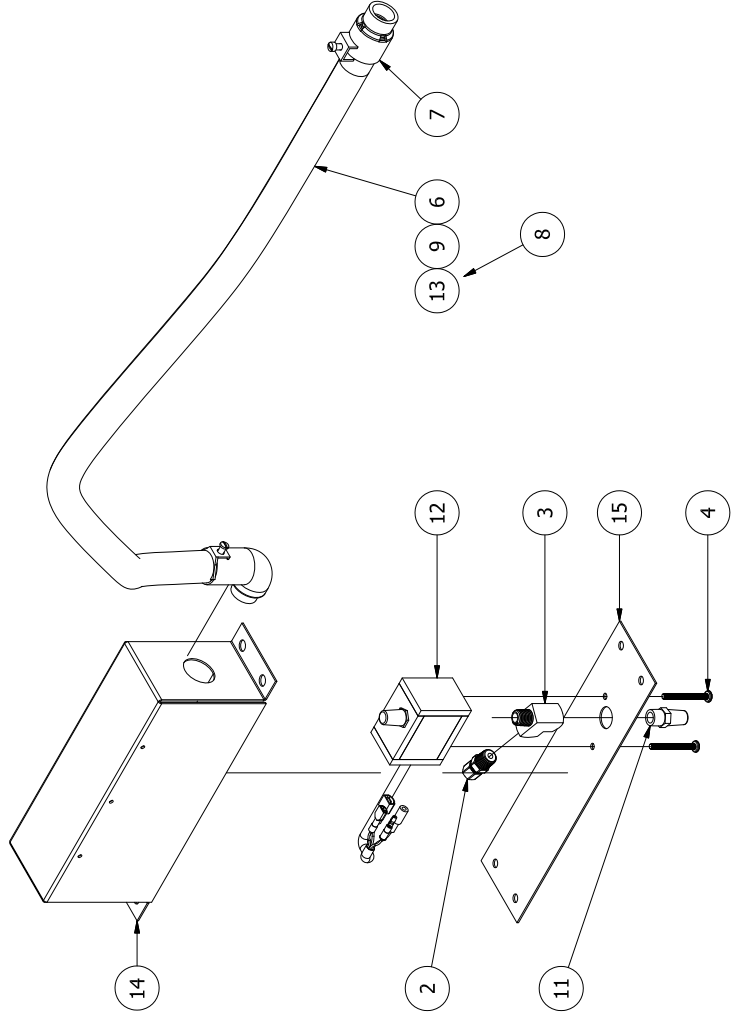
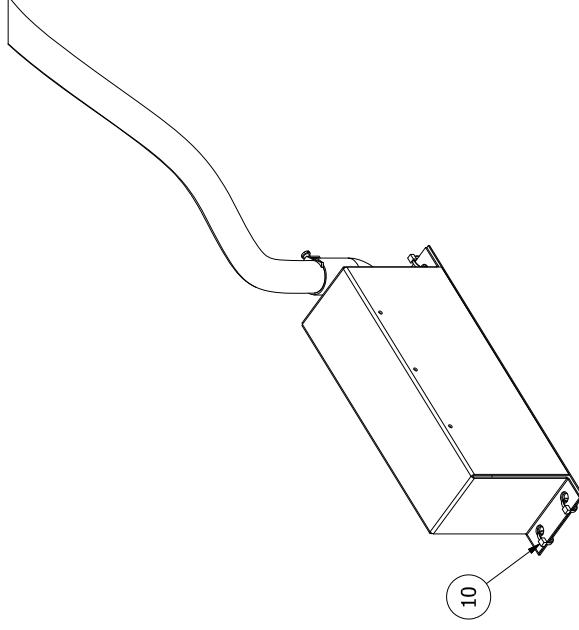

© RAILWAY EQUIPMENT CO. 2021

UNLESS OTHERWISE SPECIFIED:
 DIMENSIONS ARE IN INCHES
 DECIMALS TO THIRDS
 .XX, .X - FRACTIONS
 .00 NOT SCALE DRAWING
 DRAWN: TBERTOLDI
 DATE: 5/11/2018

RAILWAY EQUIPMENT CO.
 MINNEAPOLIS, MINNESOTA (763) 872-2800

TITLE: ASSY, 5HP PRESSURE SWITCH AND SENSOR BLOWER ASSEMBLY

DWG NO: 9538-0151A
 REV: A
 SCALE: 1/4" = 1" DRAWING: B SHEET 1 OF 1

Pressure Switch Calibration

These steps describe how to calibrate the pressure switch to turn off when 90% of the air intake is blocked.

1. The Pressure Switch comes pre-calibrated based on the horsepower of the Gas Hot Air Blower. If adjustment is needed they can be adjusted between 0.12"wc to 5.0"wc. Turning the adjustment screw on the pressure switch has these effects to the pressure set point:
 - a. Clockwise (CW) = increase pressure set point
 - b. Counterclockwise = decrease pressure set point
2. Run the GHAB in a normal manner such that air flow and flame are present. If air flow cannot be proven, turn the Pressure Switch adjustment screw Counter Clockwise (CCW) until the air flow LED turns on.

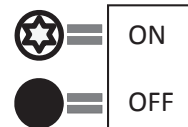
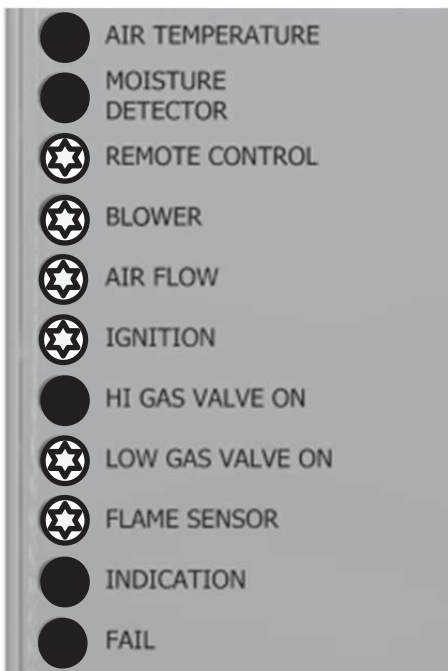

3. Block the air intake 90% with cardboard. The suction from the GHAB will hold the cardboard in place.

4. Turn the Pressure Switch adjustment screw Clockwise (CW) until the Air Flow LED on the control module turns off. It is now calibrated.

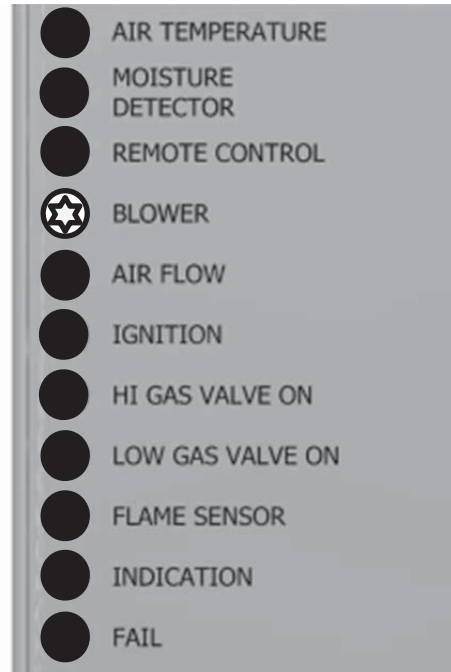

MENU SELECT STATUS

Outside Temp 0°F
Preset Value 38°F
Displays the current ambient temperature and temperature preset value.

Gas Pressure 0.0 IN
Duct Pressure 0.0 IN
Displays gas and duct pressure while running.

Rail Temp 0°F
Duct Temp 0°F
Displays the rail temperature and duct temperature.

Total Gas 0.0 FT
Reset Gas 0.0 FT
Total gas displays the calculated amount of gas that has been used. Reset is the same as total but it can be reset.

Hour Meter 0
Reset Hour 0
Total hours GHAB has been running. Reset is the same as total but it can be reset.

Tank Level 80%
Bat 4.5 V, Temp 0°F
Displays level of propane in percent full. Bat displays level of the tank monitor. Temp displays battery monitor temperature.

Name
Shows you the name for your unit.

MENU SELECT FACTORY DEFAULTS

Factory defaults is used to place all parameters back to factory default settings. Follow the message on the screen to do this.

MENU SELECT SET POINTS

Password
Push up or down to change the password. Use password 5 for critical setpoint.

Select Temperature
Setpoint 38°F
Push up or down to change the set point.

Select Run Timer
Value 0 Minutes
Push up or down to change the time.

Select Snow Timer
Value 30 Minutes
Push up or down to set time following a snow event.

Select Snow Sensor
Speed 1 Seconds
Push up or down to select from 1 to 60 seconds before snow cycle starts.

Select Snow Sensor Indication
OFF / ON

Select Fault Indication
OFF / ON

Select Start Delay
Value 0 Seconds
Push up or down to select start delay (10 sec increments).

Select Burner Operation
LOW, HIGH, AUTO, or AUTO OFF.

Operation Mode
NATURAL, PROPANE, COLD AIR, COLD AIR/PROPANE, or COLD NATURAL

Select Motor Size
Push up or down to select the motor you have for your unit.

Rail Temp 0.0 °F
Setpoint 60.0 °F
Push up or down to set the setpoint.

DuctTemp 0.0 °F
Setpoint 250.0 °F
Push up or down so set the setpoint.

Local With/ Without Air Temp
Push up or down to select.

Remote With/ Without Air Temp
Push up or down to select.

Auto Overtemp Reset
Push up or down to enable or disable.

Select F or C
Push up or down to select either °F or °C.

My IP Address
Displays the IP address.

Machine S/N
Displays the S/N for the GHAB unit.

Program Rev
Date
Displays the program revision and the date it was compiled on.

MENU SELECT FAULT HISTORY

Flame Loss 0
Flame On 0
Push up or down to clear.

Sail Loss 0
Sail On 0
Push up or down to clear.

Motor Current 0
Comm Reset 0
Push up or down to clear.

Motor V Fault 0
Overload 0
Push up or down to clear.

Gas Valve Leak 0
Pressure Fault 0
Push up or down to clear.

Duct Pressure Fault 0
Vap. Press Low 0
Push up or down to clear.

Gas Level Low 0
Push up or down to clear.

Over Temps Warning
Counter 0
Push up or down to clear.

Auto Overtemp Reset
Counter 0
Push up or down to clear.

Power Up Counter 0
Push up or down to clear.

Status Log